



ROHDE & SCHWARZ

Communications
Division

Operating Manual

RDS CODEC

DMC01

2046.6004.02

DMC01C

2046.7000.02

Printed in the Federal
Republic of Germany

)

)

)

)

Operation - Hardware	1
1 Data sheet	
2 Preparation for Use	
3 Operating Instructions	

Operation Coder	2
Link Protocol	

Operation Coder	3
Universal Encoder Protokol	
EBU Specification	
Request Protokol	
Manufacturer's Specific Protokol	

Operation Decoder	4
Link Protokol	
Terminal Protokol	

Appendix 1	5
Terms and Explanation of Abbreviations	
Appendix 2	
AF codes	

)

)

)

)



ROHDE & SCHWARZ

HERSTELLER - BESCHEINIGUNG
zur Funk - Entstörung gemäß Verfügung des BMPT

Hiermit wird bescheinigt, daß der / die / das:

RDS-CODEC Kassette DMC01C 2046.7000.02

(Gerät, Typ, Bezeichnung)

in Übereinstimmung mit den Bestimmungen der BMPT-AmtsblVfg 243 / 1991 funkentstört ist.
Der vorschriftsmäßige Betrieb mancher Geräte (z.B. Meßsender) kann allerdings gewissen Einschränkungen unterliegen.

Dem Bundesamt für Zulassungen in der Telekommunikation wurde das Inverkehrbringen dieses Gerätes angezeigt und die Berechtigung zur Überprüfung der Serie auf Einhaltung der Bestimmungen eingeräumt.

Diese Hersteller - Bescheinigung ist das Ergebnis einer Prüfung, die durch die Qualitätssicherung der Firma **ROHDE & SCHWARZ** in Übereinstimmung mit den oben angeführten Bestimmungen durchgeführt worden ist.

Achtung!

*Bei Verwendung des Gerätes an **offenen Meßaufbauten** ist darauf zu achten, daß die Störstrahlungsgrenzwerte gem. AmtsblVfg 243/1991 an den Grenzen der Betriebsräume oder der zusammenhängenden Betriebsstätte unter allen Betriebsbedingungen eingehalten werden.*

(AmtsblVfg 243 / 1991 Anlage 1, § 2, Abs. 1.8.1)

*Dieses Gerät erfüllt auch in **Meßsystemen** zusammen mit weiteren funkentstörten **ROHDE & SCHWARZ**-Geräten die Bestimmungen des BMPT. Werden Anlagen mit anderen Geräten zusammengestellt, so ist der Betreiber dafür verantwortlich, daß auch diese Anlagen die Funkstörgrenzwerte gemäß AmtsblVfg 243 / 1991 einhalten. Hierbei kommt der Verwendung ausreichend geschirmter Verbindungskabel besondere Bedeutung zu.*

(AmtsblVfg 243 / 1991 Anlage 1, § 2, Abs. 5)

ROHDE & SCHWARZ GMBH & Co. KG

München, den 07.07.93

(Ort und Tag)



Unterschrift

2046.7000.02 - 01

)

)

)

)



ROHDE & SCHWARZ

Communications
Division

Operating Manual

Hardware

RDS CODEC

DMC01

2046.6004.02

DMC01C

2046.7000.02

Printed in the Federal
Republic of Germany

)

)

)

)

DMC01- DMC01C Contents

Table of Contents

1	Data sheet DMC01 and DMC01C	
2	Preparation for Use	
2.1	Putting into Operation	5
2.1.1	AC Supply	5
Fig. 2-1	Block diagram of DMC01 and DMC01C	5
2.1.2	RFI Regulations	5
2.1.3	Installation	5
Fig. 2-2	Installation of DMC with stereocoder	6
Fig. 2-3	Installation of DMC without stereocoder	6
Fig. 2-4	Installation of DMC with data link	6
2.1.4	Switching on	7
Fig. 2-5	Sequence of device start	7
	Cold start	7
	Warm start	7
2.1.5	Putting the Device into Operation	7
	Required equipment	8
Fig. 2-6	Setup for putting into operation	8
	Overview	8
	Putting into operation	8
	Phase adjustment	8
Fig. 2-7	Phase adjustment	9
	Level adjustment	9
	Loading of basic RDS data	9
	Loading of device parameters	10
	Configuration of serial interfaces	10
	Configuration and operation of parallel interfaces	10
2.1.6	Checking the Lithium Battery	10
2.1.7	Device Addresses	10
2.2	Coding	11
Fig. 2-8	Position of coding links	11
	Coding links for installation	11
	MPX addition	11
	Bypass	11
	Gain	11
	Coding links for servicing	12
	Trimmers	12
2.3	Connectors	13
2.3.1	Serial Interfaces (DTE)	13
	Interface to RS-232-C	13
	Interface to RS-485	13
2.3.2	MONITORING Connector	13
2.3.3	REMOTE CONTROL Connector	14
2.3.4	MESSAGES Connector	14
2.3.5	Rack Connector	14
2.4	Modification for Use as Bench Model or Rackmount (Design 90)	15
2.4.1	Bench Model	15
2.4.2	Rackmount	15
2.5	Installation of DMC01C Plug-in	16
2.5.1	Installing the Plug-in into the Subrack	16
2.5.2	Installing the Subrack into a 19" Rack	17

DMC01- DMC01C Contents

3	Operating Instructions	
3.1	Legend for Front and Rear	18
3.1.1	DMC01 Rackmount	18
Fig. 3-1	Front view of DMC01 rackmount	18
Fig. 3-2	Rear view of DMC01 rackmount	19
3.1.2	DMC01C Plug-in	20
Fig. 3-3	Front view of DMC01C plug-in	20
Fig. 3-4	Rear view of DMC01C plug-in	21
3.2	Overview	22
	DMC01 rackmount	22
	DMC01C plug-in	22
3.3	Interfaces	23
3.3.1	Serial Interfaces	23
	Transmission modes	23
	Coder interfaces	23
	Decoder interface	23
	Default interface	23
3.3.2	Monitoring Interface	23
	Coder monitoring	23
	Decoder monitoring	23
3.3.3	REMOTE CONTROL Interface	24
3.3.4	MESSAGES Interface	24
	Reference Table	25

RDS Codec DMC 01



For several years, the Radio Data System (RDS) has been an integral part of public and private VHF-FM broadcasting in most European countries. In the USA, the Radio Broadcast Data System (RBDS), an adaptation of the European RDS standard, opens up another wide field of application so that RDS will gain increasing importance worldwide. Future applications by a multitude of users as described in the Rohde & Schwarz brochure "The Radio Data Wonderland" (PD 756.8955.22) present new requirements as regards the price and functions of RDS coding and decoding equipment. For this reason Rohde & Schwarz developed the favourably priced RDS Codec DMC01 in addition to the FM Radio Data Coder DMC05 and FM Radio Data Decoder DMDC05 to ARD/Telecom specifications. The following features played a key role in the new development:

- reducing the size to a minimum thanks to the use of special LSI components (eg communication controller, ASICs)
- communication of several codecs (master-slave operation) via RS-485 interface or serial bus (SERBUS) (under preparation)
- simple firmware update (eg for future RDS functions) via serial interface with the aid of flash EPROMs and special gate array

To enable universal use of the equipment in different countries and for different transmitters, the codecs comply with a number of technical prerequisites. It is for instance possible to vary the RDS signal level at the coder output within wide limits so that a defined RDS deviation can be set for different transmitter input impedances. Moreover, DMC01 enables the summation of the stereo MPX and the RDS signal. This proves useful if the associated stereocoder is not equipped with an RDS signal input. Synchronization of DMC01 is possible by way of the 19-kHz pilot or directly to the MPX signal of the stereocoder. Finally there is the versatile remote-control capability of DMC01 which allows system integration without any problem.

- maximum performance both in terms of hardware and software (RDS coder/decoder functions and VRF signal generation in one unit)
- use with any VHF-FM transmitter for all applications (hardware and software flexibility)

Front and rear panels of DMC01 bench model



Technical description

The hardware ...

The RDS equipment comes in two models using the same basic module:

- bench model DMC 01 (1 height unit)
- plug-in unit DMC 01 C for 19" adapters
 - upright incorporation in NU system adapter (5 height units) and
 - lying flat in 19" Adapter ADAPT-R (1 height unit)

The heart of the **basic module** is a powerful microcomputer for controlling the hardware functions, managing the RDS data and driving the interfaces. Depending on the extension, four to six RS-232-C interfaces are available (partly switchable to RS-485). The software is organized in electrically erasable flash memories so that firmware update is possible via the serial interfaces without exchanging EPROMs. Functions such as non-volatile data storage, watchdog, real-time clock, remote-control inputs and signalling relays are standard with DMC 01.

The RDS and VRF signals are produced by digital synthesis. The stored samples are read out by an **RDS/VRF ASIC**, which includes the complete logic circuitry, and then D/A-converted. The ASIC also contains the digital circuits of clock and synchronization processing.

The analog **RDS/VRF level amplifier** can be adjusted in 10-dB steps from 0 to 30 dB for matching with different transmitter input impedances, fine level adjustment is quasi-continuous in the selected gain range. The signals are applied and brought out via decoupled balanced and unbalanced inputs and outputs on the front and/or the rear panel depending on the codec model.

If DMC 01 is operated with a stereocoder that comes without an auxiliary signal input (eg SCA), the **internal summing amplifier** of DMC 01 combines the stereo MPX and RDS as well as VRF signals. In the case of an AC supply failure for instance, the transmitted program signal is through-connected from the MPX input to the MPX/RDS output via a bypass circuit.

The **RDS decoder chip** decodes the received MPX/RDS signal and retrieves the RDS data. With the data-link (re-broadcasting) function, these data are applied to the microcomputer which generates the new RDS data stream.

... and the associated software

The software for RDS Codec DMC 01 is based on software proven many times over and implemented to ARD/Telecom specifications in DMDC 05 and DMDC 05, the separate software for coder and decoder being combined to form the software for DMC 01. Existing protocols for interfaces, internal software configurations and customer-specific extensions have been maintained and new functions (eg menu and device control) included. This ensures maximum compatibility with the existing product line. Although the hardware is new, the customer can continue to use the existing application software and add only the required new functions. As before, the coder software supports several data sets, the data input and output via line interfaces (important for instance for CLUB, a coder loading and utilization program) and the internal sequence control. New implementations are TNPP and the universal EBU protocol for paging applications for instance.

With the decoder software all RDS data are evaluated, read out on the display (of the bench model) and output via interfaces. In the case of out-of-tolerance conditions monitoring functions for RDS data and block error rates release messages allowing continuous check of the transmission quality.

Two DMC 01 C units in a KB-80 cabinet, the 19" Adapter ADAPT-R being required for incorporation. Also fitted: two horizontal front panels (Mounting Kit DMC 01-R)



Specifications

RDS signal

Coding
Modulation

Centre frequency
Bandwidth

Level

RDS level ranges
with 0-dB gain
with 10-dB gain
with 20-dB gain
with 30-dB gain

Phase

RDS pilot

RDS-VRF

Linear distortion

VRF signal

VRF level ranges

with 0-dB gain
with 10-dB gain
with 20-dB gain
with 30-dB gain

Modulation depth
A to F area identification
Traffic announcement
identification
(area identification [BK] can
be switched off)

Signal generation

RDS/VRF amplifier

Max. output level
Gain
Level variation

Synchronization

External

Internal

Inputs

Sync/MPX summation

Connector

Type

Max. input level

Pilot level

Input impedance

Unbalance rejection

MPX decoder (rebroadcasting) input

Connector

Type

Max. input level

Input impedance

Unbalance rejection

Decoding

Functions

to CENELEC EN 50067 and ARD
standard specifications 5/3.8
differential and biphasic
double-sideband amplitude modulation
(DSB-AM) with suppressed carrier
57 kHz \pm 6 Hz
 \pm 2.4 kHz

55 to 437 mV_{pp}
174 to 1,381 mV_{pp}
550 to 4,370 mV_{pp}
1,740 to 13,800 mV_{pp}

adjustable in steps of $<1^\circ$, range 0 to
360° referred to 57 kHz
switchable 0°/90°
 <0.5 dB between upper and lower
sidebands

to ARD standard specifications 5/3.6
all with area [BK] and traffic an-
nouncement [DK] identification
416 to 950 mV_{pp}
1,315 to 3,004 mV_{pp}
4,160 to 9,500 mV_{pp}
... to 14,000 mV_{pp}

60% \pm 5%

30% \pm 5%

digital signal synthesis by RDS/VRF
gate array (ASIC)

14 V_{pp} into 600 Ω
link-selected, 0/+10/+20/+30 dB
 <0.5 dB

to auxiliary pilot of stereocoder or to
pilot of MPX signal, frequency 19 kHz
 \pm 2 Hz
automatic switchover to internal crystal
oscillator if external pilot fails,
frequency 19 kHz \pm 2 Hz

either for 19-kHz pilot or for complete
FM stereo MPX signal

Lemosa Triax series 0 or BNC
balanced or unbalanced

9 V_{pp}
(sinewave)
TTL (squarewave) or 0.4 V_{pp} to 1 V_{pp}
(sinewave)

>5 k Ω
 >34 dB to DIN 45404 (40 Hz to
76 kHz)

MPX input for RDS decoder; the de-
coded RDS information may be used
for rebroadcasting applications (inter-
nal data link)

Lemosa Triax series 0 or BNC
balanced or unbalanced

9 V_{pp}
 >5 k Ω
 >34 dB to DIN 45404 (40 Hz to
76 kHz)

evaluation in part to ARD standard
specifications 5/3.9
display and output of decoded RDS
data, detection of information
change, synchronization errors, block
error rates with fault message, source
monitoring, error detection switchable
to error correction

Outputs

57-kHz (+MPX) main output

Connector

Type

Max. load

MPX summation

Gain

Level variation

Frequency response flatness
(40 Hz to 76 kHz)

Lemosa Triax series 0 or BNC
balanced or unbalanced, no DC com-
ponent, with bypassing circuit
300 Ω || 5000 pF
link-selected, DC-coupled
0 dB
 <0.5 dB
 <0.5 dB

57-kHz (+MPX) test output

Connector

Type

rating same as main output
BNC
unbalanced

Interfaces

Remote control

Connector

Messages

16 active-low TTL inputs with internal
pull-up resistors
37-contact D female, subminiature
16 floating relay contacts (for DC:
max. 100 V, 0.5 A, 10 W); two mes-
sages codable to optocouplers or TTL
ports

Data interfaces

DMC 01

DMC 01 C

Connector

Transmission rate

Data format

for input and output of RDS data and
setup functions; two interfaces switch-
able to RS-485

6 serial interfaces, asynchronous,
RS-232-C

4 serial interfaces, asynchronous,
RS-232-C

9-contact D male, subminiature
300 to 19,200 baud
selectable

Data processor

16-bit microprocessor 80C186 EC-
16, flash memory, battery-supported
SRAM, EEPROM, realtime clock, en-
hanced serial communication control-
ler, gate array for firmware update
via serial interface; RDS data man-
agement for 8+1 software-defined da-
ta sets and for nonvolatile device con-
trol (modulators, interfaces, front pan-
el) and storage of device status

Front panel (DMC 01 only)

Display

software-driven menu functions for de-
vice setup, selection of operating
mode, level, data sets, fault message
and all decoder functions as well as
display of RDS information and oper-
ating parameters
LCD with 2 x 40 characters

General data

Rated temperature range

Operating temperature range

Storage temperature range

Power supply

Dimensions (W x H x D)

Bench model (DMC 01)

Plug-in RDS Codec (DMC 01 C)

19" rackmount (ADAPT-R)

+5 to +45°C

0 to +50°C

-40 to +70°C

88 to 264 V, 47 to 63 Hz

426.7 mm x 43.2 mm x 460 mm

37.1 mm x 207.5 mm x 437 mm

482.6 mm x 43.2 mm x 465 mm



Versatile RDS applications

The increasing importance of RDS as a commercial multidata service with VHF-FM sound broadcasting opens up numerous applications for the RDS codecs:

DMC 01 for low-cost applications

Many local transmitters or small transmitter networks use RDS merely to transmit the program service name (PS) for program identification. If a transmitter network operates on different frequencies, the alternative frequencies (AF) included in the RDS data stream allow the car driver to receive the same program during an extended drive. To cost-conscious users in particular, DMC 01 offers a professional, low-cost entry into RDS and allows step-by-step system extension for dynamic data, paging, remote control and diverse other services.

DMC 01 for paging systems

For operating an RDS paging system, especially reliable and powerful coders are indispensable to ensure safe and fast RDS information processing. Application of the paging data is by TNPP (Telocator network paging protocol) or the universal EBU protocol. The decoder functions of DMC 01 with its paging evaluation software allow decoding of the transmitted paging data for monitoring with full display of the paging information on a PC. Moreover, monitoring of the RDS transmission quality in general is possible using the integrated RDS monitoring functions.

DMC 01 for TMC applications

With digital traffic radio, ie traffic message channel (TMC), coded information is sent via RDS on the place, cause, type and duration of traffic holdups combined with instructions for the road users. Codecs DMC 01 handle insertion of the TMC data at the transmit end as well as evaluation, monitoring and display at the receive end, eg for intelligent traffic-jam indicators and active road signs along critical road sections.

DMC 01 for emergency broadcasting systems

If disasters or major accidents occur, RDS emergency warning systems (WARI, EWS) are used to transmit, over the regions concerned, digital switching signals for siren control, alarms addressed to the emergency services and instructions for the population at large. For this reason DMC 01 is equipped with special remote-control functions for switching over between normal and emergency operation as well as with EWS-specific RDS data generation.

DMC 01 for RDS applications in broadband communication

A growing number of FM programs distributed in broadband communication (cable) networks are provided with RDS. The RDS data are generated either directly at the broadband communication headend or, with FM programs received, retrieved from the multiplex signal, processed and applied as the new RDS signal to the FM

modulator for feeding the cable network (rebroadcasting). For this purpose, the plug-in RDS Unit DMC 01 C with integrated rebroadcasting functions is available for use in the NU system from Rohde & Schwarz.

DMC 01 for low-power FM transmitters

In the NU system RDS Unit DMC 01 C allows low-power FM transmitters between 20 and 400 W to be equipped with RDS at a favourable price, the installation requiring a minimum of space and effort.

DMC 01 to ARD/Telekom specifications

The ARD/Telekom RDS specifications stipulate in detail the hardware and software characteristics of RDS/VRF equipment. To enable the use of Codecs DMC 01 in accordance with the specifications, these standards were taken as a reference in the design of the implemented functions. This holds for the data interfaces, hardware and software functions, signal parameters, internal sequence control, monitoring functions, data link function, etc.

Further applications

DMC 01 is also suitable for use in navigation and localization systems based on DGPS (Differential Global Positioning System), for text and data transmission to newspanels and large-size displays as used in advertising, news distribution, traffic control, etc.

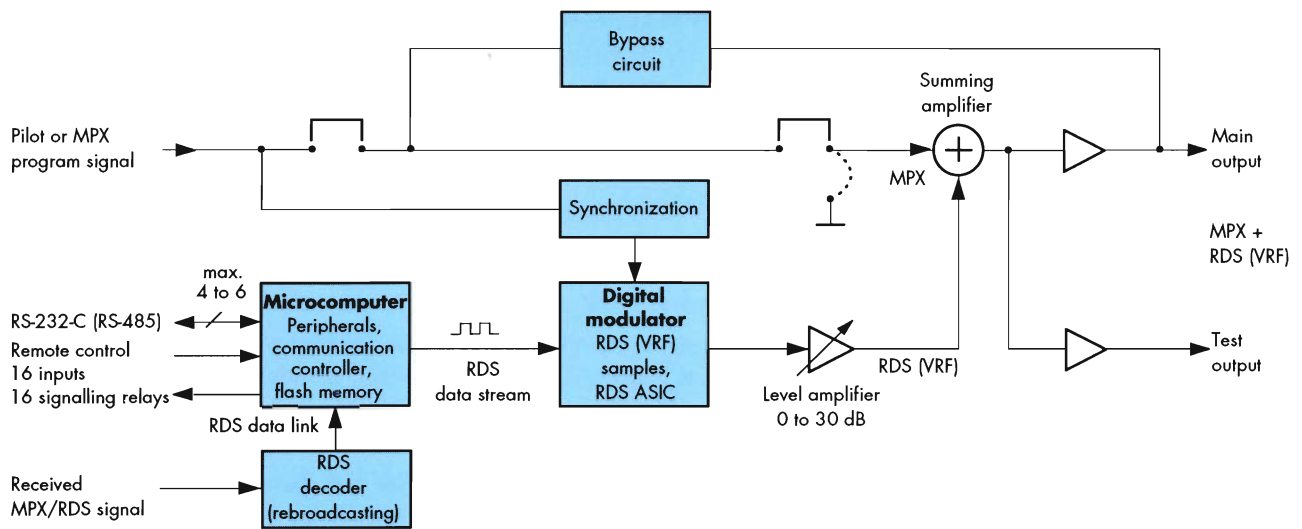

Ordering information

Order designations

Bench model (basic model)	RDS Codec DMC 01	2046.6004.02
Plug-in unit (basic model) including power supply, suitable for NU broadband communication system or for use in 19" racks	Plug-in RDS Codec DMC 01 C	2046.7000.02

Special models of DMC 01/DMC 01 C on request

Accessories for bench model

19" Mounting Kit with connectors (3 x Lemos)	DMC 01-T	2046.6404.02
Set of Mating Connectors (2 x 37-contact D subminiature)	DMC 01-T	2046.6410.02

Accessories for plug-in unit

Set of Mating Connectors (2 x 37-contact D subminiature)	DMC 01-T	2046.6410.02
---	----------	--------------

For incorporation into 19" racks an adapter is available accepting one or two DMC 01 C plug-ins. For this purpose the following accessories are required:

19" Adapter including blank panel Mounting Kit for ADAPT-R (two DMC 01 C horizontal front panels)	ADAPT-R DMC 01-R	2046.7300.02 2046.7100.02
---	---------------------	------------------------------



Rohde & Schwarz GmbH & Co. KG · Mühldorfstraße 15 · 8000 München 80 · Germany
Telephone +49 89 41 29-0 · Fax +49 89 41 29-3567

2 Preparation for Use

2.1 Putting into Operation

2.1.1 AC Supply



The device can be operated in the AC supply range from 88 to 264 V without any manual switchover being necessary.

The power fuse is located in the device. A fuse failure is indicated on the front panel of the DMC01 rackmount and signalled at a contact of the MESSAGES connector.

The DMC01C plug-in is provided exclusively for fault signalling at the rack connector (X11, power supply).

2.1.2 RFI Regulations

To observe the RFI regulations related to the radio protection mark, shielded cables must be used for connecting the interfaces, the shields being taken to protective earth. Moreover, metallized connector shells should be used and connected to the shield.

2.1.3 Installation

The 57-kHz subcarrier signals are added to the stereo multiplex signal at a suitable summing point. Normally the auxiliary signal input of the stereocoder is used. For this purpose the main output should be connected to the auxiliary signal input of the stereocoder.

If an MPX signal is available, the integral summing point of the DMC01 or DMC01C can be used.

The 57-kHz output signal should be synchronized to a 19-kHz pilot to obtain frequency- and phase-locked coupling as required by the specifications. For this purpose the auxiliary pilot output of the stereocoder is normally connected to the sync input (main input) of the DMC.

If no auxiliary pilot is available, synchronization to the pilot carrier of the MPX signal is possible.

Synchronization is not required for transmission systems using no pilot. In this case the 57-kHz subcarrier is produced by a crystal oscillator.

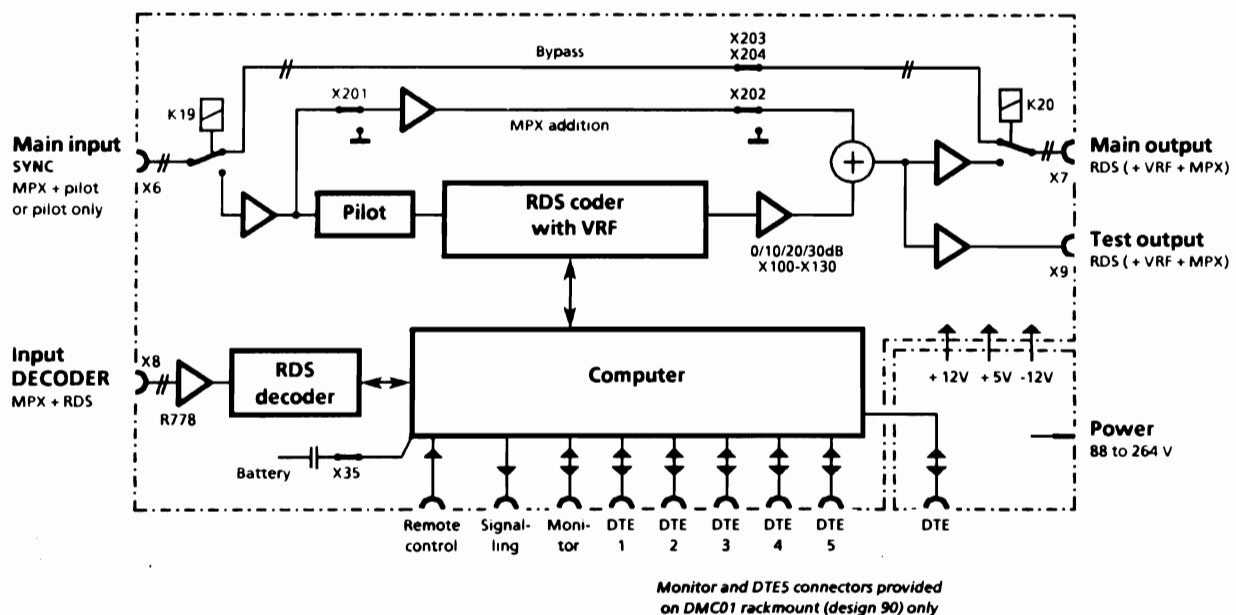

Fig. 2-1 Block diagram of DMC01 and DMC01C

DMC01 - DMC01C Preparation for Use

Installation

In most cases the DMC will be installed at the VHF-FM transmitter (usually in the transmitter rack). The following modes of operation are possible:

a) Operation of RDS coder with stereocoder

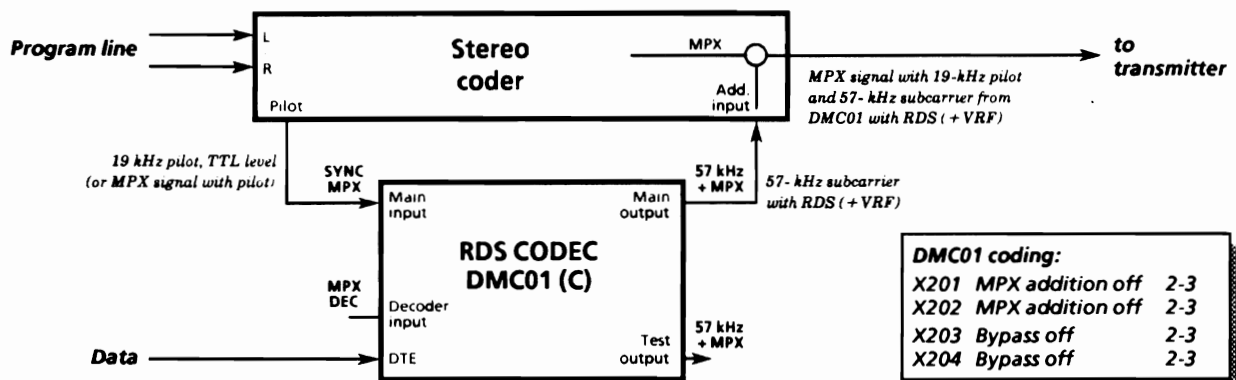

Fig. 2-2 Installation of DMC01 with stereocoder

b) Operation of RDS coder with MPX signal

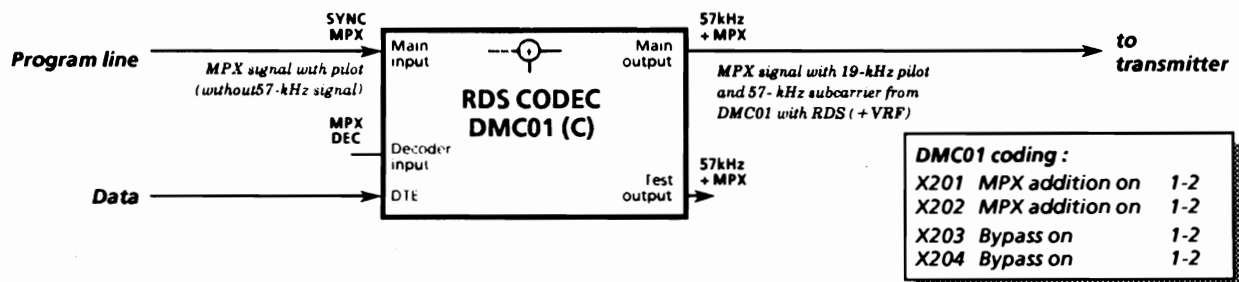
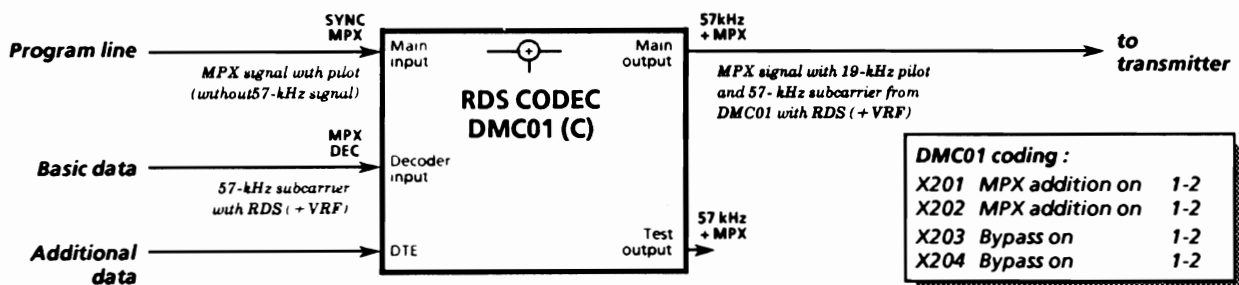

Fig. 2-3 Installation of DMC01 without stereocoder

c) RDS data link



Addition of MPX signal also possible in stereocoder (see Fig. 2-2)

Fig. 2-4 Installation of DMC01 with data link

Coding depending on mode :
(see also Section 2.2)

Output level
Addition of MPX signal
Bypass

X100/X110/X120/X130
X201/X202
X203/X204

DMC01 - DMC01C Preparation for Use

2.1.4 Switching on

See Fig. 2-5: Sequence of startup

Upon power up a warm start is performed as standard. The setup prior to switching the device off is maintained, ie restored.

A warm or a cold start can be performed depending on how long the RESET key is held down:

- Cold start: brief stroke (<1 second)
- Warm start: pressing the key down for >2 seconds

Depending on the model, the type of start is indicated on the front panel and/or a computer (terminal). Next all internal tests are carried out. If a fault is found, a message is issued.

Cold start

A cold start causes default initialization of the device setup and clears all data backed up by the battery.

A cold start occurs upon switching the device on for the first time or after briefly pressing the RESET key. This also takes place if the battery or RAM is found to be faulty upon power up or after entering the cold start command on a serial interface. In the case of a cold start all LEDs and all pixels of the alphanumeric display will light up on the DMC01 front panel.

Warm start

Upon power up a warm start is performed as standard. Moreover, a warm start is produced after pressing the RESET key (>2 seconds) and after entering the warm start command.

In the case of a warm start the device setups, the switching and operating states as well as the contents of the data and error memories saved in the battery-supported RAM are used. The device continues operation with the settings and data valid prior to switchoff. A failure of the AC supply may however affect the data memories.

2.1.5 Putting the Device into Operation

Note:

The device is supplied with preset values, eg phase and level. These default values are used after each cold start.

Basically the device is thus ready for operation.

Use in Europe:

Normally a stereo transmission system with a 19-kHz pilot is used. After putting the device into operation the phase of the 57-kHz subcarrier should be adjusted to that of the 19 kHz pilot and the level should be checked.

Use in America:

The levels used are considerably higher than in Europe. Since, however, no pilot signal is used, a phase adjustment is not required, ie the preset (default) values will always be used.

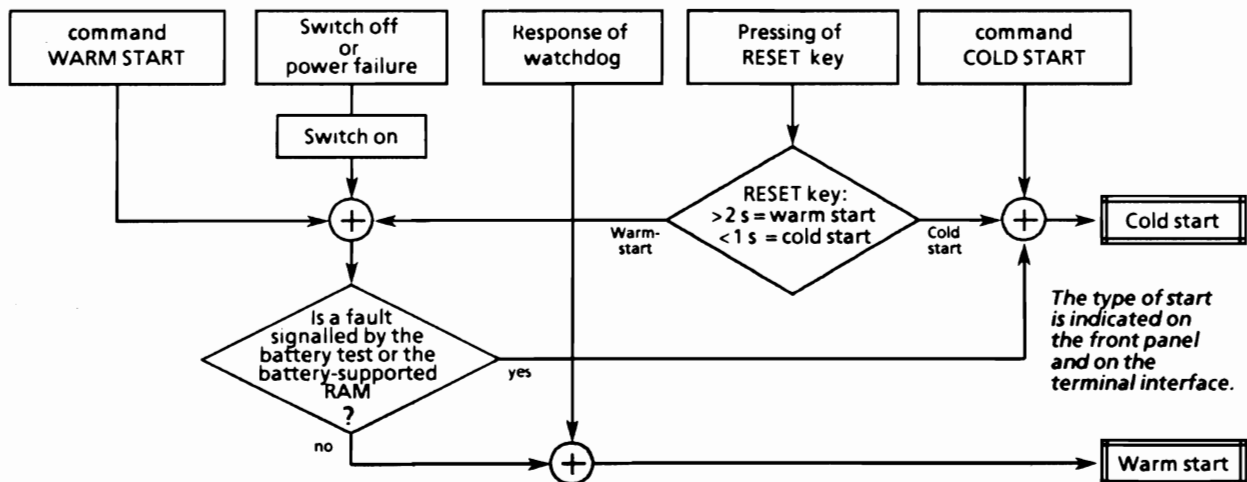

Fig. 2-5 Sequence of device start

DMC01 - DMC01C Preparation for Use

Required equipment

See Fig. 2-6.

A PC with a serial interface and an oscilloscope, possibly a peak-responding voltmeter are required for these adjustments. With the DMC01, adjustment from the front panel by way of the menu is also possible.

Each unit is supplied with a floppy running under DOS on a PC and containing a simple load and adjustment software which permits the following steps to be executed.

Overview

- ▶ Adjustment of the phase between 19-kHz pilot and 57-kHz VRR/RDS signal
Oscilloscope required
Adjustment only for transmission systems with pilot
- ▶ Checking the RDS level and, if required, the VRF level
- ▶ Loading the basic RDS data (PI, PS, etc.)
- ▶ Loading the device parameters
- ▶ Configuration of serial interfaces:
DMC01 rackmount: DTE, DTE1 to DTE4
DMC01C plug-in: DTE, DTE1 to DTE3

Adjustment

DMC01 rackmount: by commands or menu
DMC01C plug-in: by commands

The Coder Loading and Utilization Program CLUB is available for easy and convenient entry of all RDS data.

Putting into operation

- ▶ Switch the DMC01/DMC01C off.
- ▶ Connect the default interface to a serial interface of the PC using an RS-232-C cable.
DMC01 rackmount: DTE5
DMC01C plug-in: DTE4
- ▶ Switch the device on (warm start).
Default interface set to 9600 baud, 8 data bits, 1 stop bit and no parity (9600/8/N/1).
- ▶ Place the floppy into the drive.
- ▶ Select the associated drive:
eg A: or B: and press <RETURN>.
- ▶ How the program is started is described on the sticker attached to the floppy. Press <RETURN> after entering the file name.
- ▶ A menu appears on the display. Using the cursor keys the desired item is selected and called up with <RETURN>.
- ▶ It is then possible to perform the required entries or adjustments in the dialog mode.
Help texts and, if required, a README file, explain the operation of the load and adjustment software.

Phase adjustment

The phase between the 19-kHz pilot and the 57-kHz subcarrier is adjusted such that the deviation is reduced to minimum.

Adjustment range
>360° referred to the 57-kHz signal

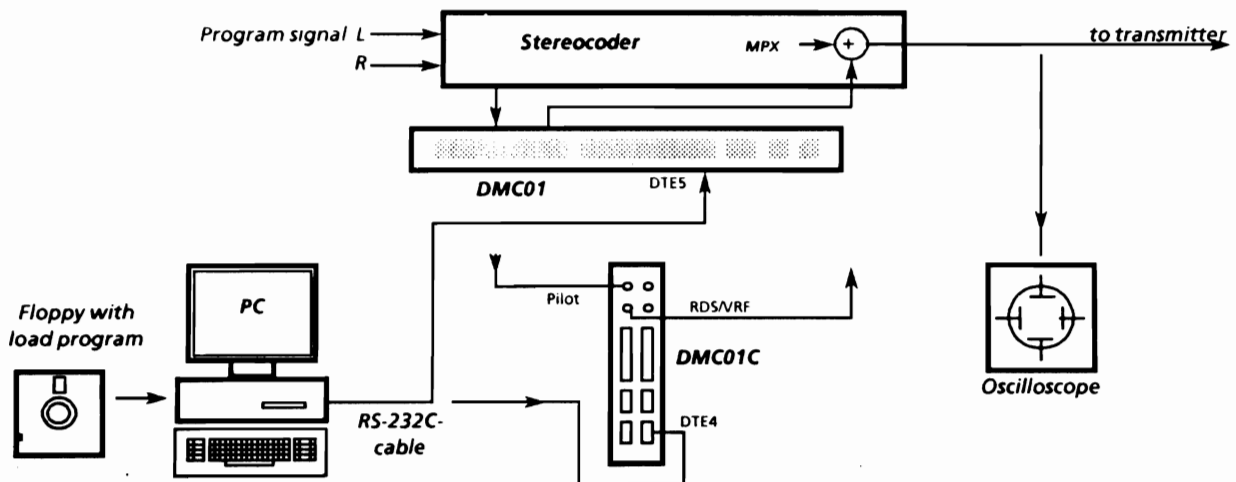

Fig. 2-6 Setup for putting into operation

DMC01 - DMC01C Preparation for Use

Description

When installing the device, phase adjustment of the 57-kHz signals to the 19-kHz pilot is required in order to reduce the necessary FM deviation to a minimum. This is done by synchronizing the device with the 19-kHz pilot (at the main input) and shifting the phase of the 57-kHz signal internally such that a minimum amplitude of the sum signal is obtained. This holds for a symmetrical waveform.

In any case the 57-kHz subcarrier signal can be shifted by more than a cycle so that correct adjustment is always ensured. However, under unfavourable conditions it may be necessary to shift the signal first by a complete cycle prior to obtaining the desired symmetry. The phase is checked on an oscilloscope connected to the stereocoder output. For this purpose the modulation, ie the program signal, must be switched off so that only the 19-kHz pilot and the unmodulated VRF signal (with the area identification disconnected) are available. This phase adjustment is also valid for the RDS signal.

Procedure

- ▶ For the test setup see Fig. 2-6.
For adjusting the plug-ins a PC is required which produces the necessary setting commands for instance by means of the load and adjustment software.
However, on rackmounts this adjustment can be made by way of the menu (without PC).
- ▶ Disconnect the program signal (stereocoder).
- ▶ Synchronize the device with the 19-kHz pilot (pilot or MPX signal at the main input).
- ▶ Disconnect the RDS signal (command or menu).
- ▶ Connect the VRF signal (command or menu).
- ▶ Disconnect the area identification of the VRF signal (command or menu).
- ▶ Use an oscilloscope to measure on the program (modulation) line to the transmitter.
- ▶ The signal consists of the 19-kHz pilot superimposed on the unmodulated 57-kHz subcarrier.
- ▶ Adjustment
Adjust the phase such that the two peaks displayed on the oscilloscope have the same amplitude (symmetry; see Fig. 2-7).
(Setting commands or menu)

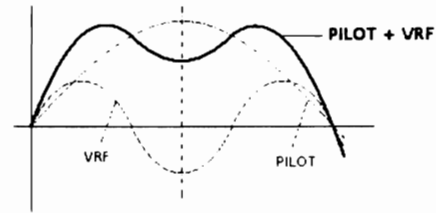

Fig. 2-7 Phase adjustment

Level adjustment

The level of the 57-kHz signal is matched to the level of the MPX signal.

With FM transmitters the following nominal deviation is standard for the individual signal components:

- ▶ Program signal (MPX) without pilot and RDS/VRF
Nominal deviation ± 40 kHz (partly ± 50 kHz)
- ▶ 19-kHz pilot
Nominal deviation approx. ± 6.72 kHz
- ▶ 57-kHz RDS signal with test pattern 0000 0000
Nominal deviation ± 1.2 kHz
- ▶ VRF signal, unmodulated 57-kHz subcarrier
Nominal deviation ± 3.5 kHz

Note:

The levels required depend on the modulation characteristic of the transmitter.

Adjustment

DMC01 rackmount: by commands or menu
DMC01C plug-in: by commands

For the range see data sheet.

Coarse adjustment:
using coding links on the PCB

Fine adjustment:
by commands or menu

Loading of basic RDS data

Adjustment

DMC01 rackmount: by commands or menu
DMC01C plug-in: by commands

DMC01 - DMC01C Preparation for Use

Loading of device parameters

Adjustment

DMC01 rackmount: by commands or menu

DMC01C plug-in: by commands

It is recommended to use the load and adjustment software supplied with the device.

Configuration of serial interfaces

Adjustment

DMC01 rackmount: by commands or menu

DMC01C plug-in: by commands

It is recommended to use the load and adjustment software supplied with the device.

Adjustable interface parameters

- ▶ Baud rate of each interface
- ▶ Hardware handshake ON/OFF

Configuration and operation of parallel interfaces

The two interfaces, ie REMOTE CONTROL (X11) and MESSAGES (X12), may be assigned user-specific functions.

- a) Setting up a remote control system
It is for instance possible to set up a remote control system with 16 (uncoded) or a total of 65,000 (binary-coded) commands
- b) Input and output of RDS data
Assignment of inputs and outputs to specific RDS data

2.1.6 Checking the Lithium Battery

The lithium battery is provided for nonvolatile storage of the RDS data, the device status, the faults occurred and for the backup of the real-time clock.

The device is supplied with the battery connected.

- ▶ The functioning of the battery is checked by an internal test circuitry.
- ▶ The functioning of the battery can also be tested by checking whether the stored settings, eg baud rate, basic data, etc., are available.

If settings are lost after switching the device off and on again, first check whether the battery is switched on. To this effect, open the device, unscrew the shielding cover of the data processor and check the position of link X35, setting it to 1-2 if required. After switching the battery on, a cold start is automatically performed.

2.1.7 Device Addresses

Each DMC01 and DMC01C has a fixed device address to EBU standard. This address is entered in the device and cannot be modified by the user. As long as the EBU protocol is used, this address allows the device to be accessed (in networks, too) whereas it is meaningless for link or terminal protocols.

The address is assigned by ROHDE & SCHWARZ and consists of 16 bits (4 hex characters). It is not related in any way to the site and encoder addresses used with the EBU protocol.

DMC01 - DMC01C Preparation for Use

2.2 Coding

To ensure proper functioning of the device, the coding links must be inserted as shown on the PCB below. If any problems occur, first check the coding. Most of the settings are meaningful only in the position given since otherwise the signal would be interrupted for testing or taken to ground.

MPX addition

For the position of links X201 and X202 see Section 2.1.3.

Bypass

For the position of links X203 and X204 see Section 2.1.3.

Gain

Gain	0 dB	10 dB	20 dB	30 dB
Link inserted	X100	X110	X120	X130

Factory setting:

Europe	0 dB	(X100 inserted)
USA	30 dB	(X130 inserted)

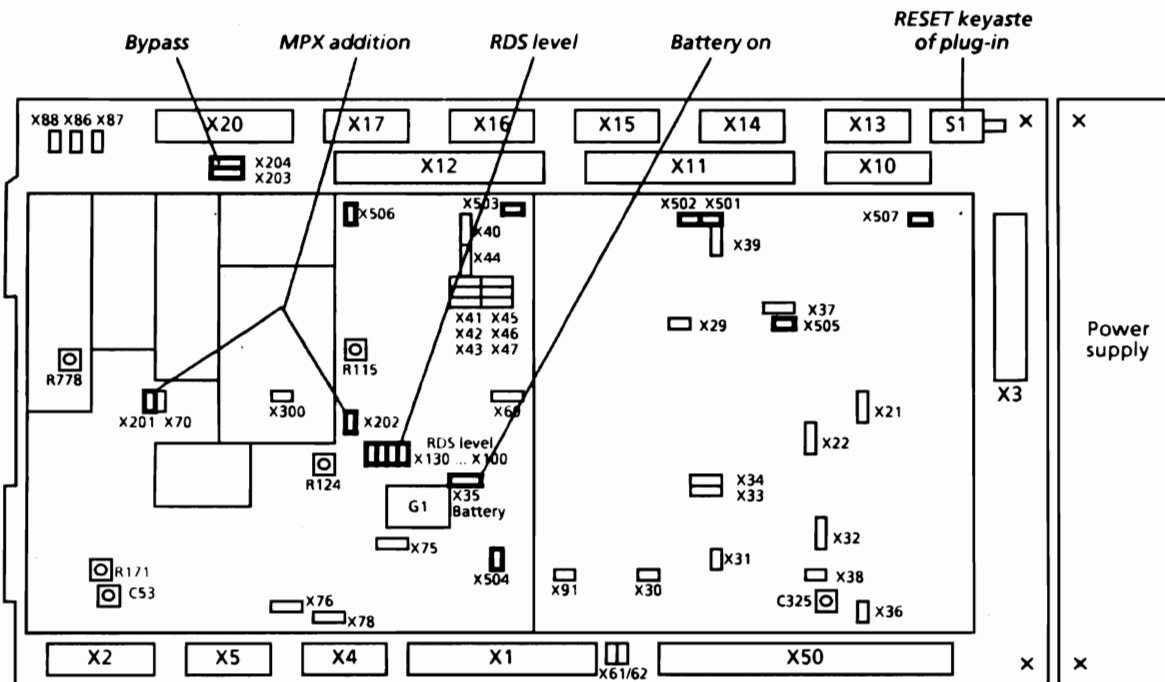

Fig. 2-8 Position of coding links

Coding links for installation

Link	Function	Position 1-2	Position 2-3	Factory setting
X201 X202	Addition of MPX signal to RDS signal	ON	OFF	2 - 3
X203 X204	Bypass for MPX signal	ON	OFF	2 - 3
X501 *	+ 5 V at serial interface DTE2 (X14 9)	ON	---	---
X502 *	+ 5 V at serial interface DTE3 (X15 9)	ON	---	---
X503 *	+ 5 V at serial interface DTE4 (X16 9) <i>Note: Not connected on DMC01C</i>	ON	---	---
X504 *	+ 5 V at serial interface DTE (X3 9) <i>Note: With DMC01C on rack connector X11.</i>	ON	---	---
X505 *	+ 5 V at serial interface DTE1 (X13 9)	ON	---	---
X506 *	+ 5 V at serial interface DTE5 (X17 9) <i>Note: Designated DTE4 on DMC01C.</i>	ON	---	---
X507 *	+ 5 v at MONITOR connector (X10 6)	ON	---	---

* The + 5-V auxiliary voltage is rated for a current of 100 mA (eg modem supply).

DMC01 - DMC01C Preparation for Use

Coding links for servicing

Link	Function	Position 1-2	Position 2-3	Factory setting	
X21	SRAM (D21/D22) 1 Mbit or \geq 2 Mbits	1 Mbit	\geq 2 Mbits	1 - 2	
X22	Flash Memory (D63/D64) 2 Mbits or 4 Mbits Address line A19 or operating voltage: + 12 V	4 Mbits (A19)	2 Mbits + 12 V via relay	2 - 3	
X29	Oscillator, 18.432 MHz	ON	---	1 - 2	
X30	Oscillator, 32 MHz	ON	---	1 - 2	
X31	Watchdog	ON	---	1 - 2	
X33	Interrupt INT4 assignment	INT-IEC	INT-RXTX1	1 - 2	
X34	Interrupt INT5 assignment	INT-I ² C	INT-DMA0	1 - 2	
X35	Battery for SRAM	ON	OFF	1 - 2	
X36	EEPROM ready	ON	---	---	
X37	LED - power (green)	MAX691	LED - power supply	2 - 3	
X38	Audiodat bit	Output	---	---	
X39	Update request	ON	OFF	2 - 3	
X40	Message 13 (relay contact or TTL level)	Relay contact	TTL (port)	1 - 2	
X41			TTL (port)	1 - 2	
X42	Message 14 (relay contact or TTL level)	Relay contact	TTL (port)	1 - 2	
X43			TTL (port)	1 - 2	
X44	Message 15 (relay contact or optocoupler)	Relay contact	Optocoupler	1 - 2	
X45			Optocoupler	1 - 2	
X46	Message 16 (relay contact or optocoupler)	Relay contact	Optocoupler	1 - 2	
X47			Optocoupler	1 - 2	
X60	Mode IEEE 488 (IEC bus)	Controller	Talker/Listener	2 - 3	
X61	Keyboard	Monitor L	Key C6	1 - 2	
X62		Monitor R	Key C7	1 - 2	
X70	Bandpass for pilot PLL	ON	OFF	2 - 3	
X75	2nd filter block	D74 bandpass	D74 lowpass	1 - 2	
X76	3rd filter block	D74 lowpass	D74 bandpass/D75	2 - 3	
X78	2nd filter block - cutoff frequency	Clock/50	Clock/100	1 - 2	
X86	Main input	floating BNC	Balanced	depending on device: BNC = floating Triax = balanced	
X87	Main output	floating BNC	Balanced		
X88	Decoder input	floating BNC	Balanced		
X91	250 kHz for Keyint ON/OFF	ON		1 - 2	
X300	Main output, balanced/unbalanced	Balanced	---	1 - 2	
Link	Function	Position A2 - A1	Position A2 - A3	Position A2 - B1	Factory setting
X32	NMI assignment	MAX691	OFF	AC-FAIL	A2 - B1

Trimmers

Trimmer	Function	Adjustment
R778	Level of decoder input	
R171	Offset of D/A converter	
C53	Frequency: 14.592 MHz	
R124	RDS amplifier	
R115	Gain of summing input	
C325	Frequency: 32.758 MHz	

DMC01 - DMC01C Preparation for Use

2.3 Connectors

2.3.1 Serial Interfaces (DTE)

The serial interfaces are configured (eg baud rate) during installation (see Section 2.1.5). To this effect the supplied load and adjustment program is used. Each interface is assigned a specific protocol.

For configuration each device is assigned a default interface with the fixed, preset transmission rate of 9600 baud (9600/8/N/1):

DMC01 rackmount	Interface DTE5
DMC01C plug-in	Interface DTE4

The interface configuration is retained after a warm start (eg power off and on) whereas it must be performed again after a cold start. After a warm start the default interface is initialized so that commands may be entered irrespective of the interface configuration.

Interface to RS-232-C

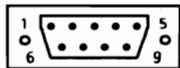

X3 - X13 - X14 - X15 - X16 - X17
X3 and X16 are not used on the DMC01C plug-in.

1	DCD	Data carrier detect (optional)
2	RxD	Received data
3	TxD	Transmitted data
4	DTR	Data terminal ready
5	GND	Signal ground (⊥)
6	DSR	Data set ready
7	RTS	Request to send
8	CTS	Clear to send
9	+ 5 V *	Output + 5 V (max. 100 mA) (codable, X501 to X506)

* In accordance with the standard + 5 V is not used.

Connecting cable for RS-232-C interface

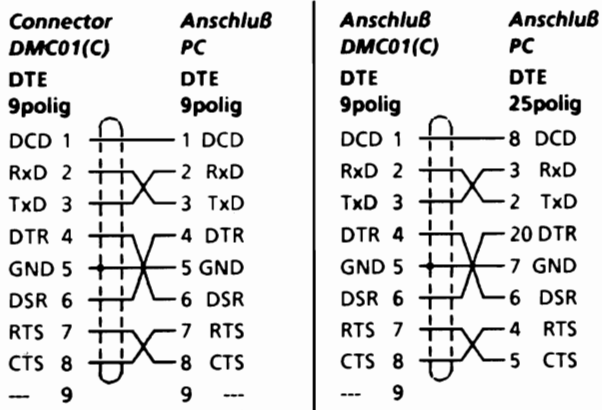

The interfaces DTE1 and DTE2 are provided for software changeover to RS-485.

Interface to RS-485



X13 and X14 (after changeover)

1	RxD (-)	Received data (-)
2	RxD (+)	Received data (+)
3	TxD (+)	Transmitted data (+)
4	TxD (-)	Transmitted data (-)
5	GND	Signal ground (⊥)
6	CTS (-)	Clear to send (-)
7	RTS (+)	Request To Send (+)
8	CTS (+)	Clear to send (+)
9	RTS (-)	Request to send (-)

Connecting cable for RS-485 interface

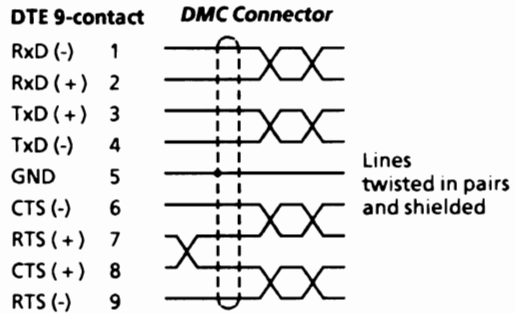

Note:

For ease of reference user-defined interface parameters can be entered into the list (reference table) attached to this manual.

2.3.2 MONITORING Connector

Inscription: MONITORING X10
(on DMC01 rackmount only)

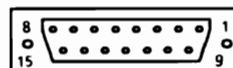

X10
on DMC01 rackmount

1	Screen (ground)	9	Reserved
2	Reserved	10	Reserved
3	Reserved	11	+ 5 V (max. 100 mA)
4	Data (coder)	12	Clock (coder)
5	Data (decoder)	13	Clock (decoder)
6	Reserved	14	Reserved
7	Reserved	15	Reserved
8	GND (⊥)		* X507 in position 1-2

DMC01 - DMC01C Preparation for Use

2.3.3 REMOTE CONTROL Connector

Inscription: REMOTE CONTROL X11

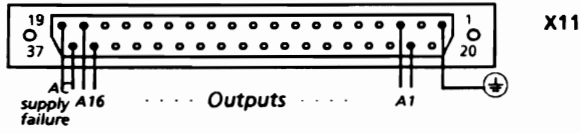

1	Screen (ground)	20	GND	⊥
2	Command 1	21	GND	⊥
3	Command 2	22	GND	⊥
4	Command 3	23	GND	⊥
5	Command 4	24	GND	⊥
6	Command 5	25	GND	⊥
7	Command 6	26	GND	⊥
8	Command 7	27	GND	⊥
9	Command 8	28	GND	⊥
10	Command 9	29	GND	⊥
11	Command 10	30	GND	⊥
12	Command 11	31	GND	⊥
13	Command 12	32	GND	⊥
14	Command 13	33	GND	⊥
15	Command 14	34	GND	⊥
16	Command 15	35	GND	⊥
17	Command 16	36	GND	⊥
18	Free	37	+ 5 V (max 100 mA)	
19	Free			

2.3.5 Rack Connector

Inscription: none

X11 is provided on the power supply of the DMC01C plug-in and not available on rack-mounts.

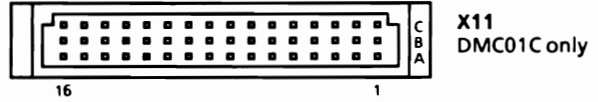

1A	Reserved	1B	DATA	Serbus	1C	Reserved
2A	Reserved	2B	INT	Serbus	2C	Reserved
3A	Reserved	3B	SYNC	Serbus	3C	Reserved
4A	Reserved	4B	CLOCK	Serbus	4C	Reserved
5A	DC ok. (TTL)	5B	ADR7	Serbus	5C	GND
6A	Reserved	6B	AC-FAIL (TTL)		6C	ADR6 Serbus
7A	Reserved	7B	DC-FAIL (TTL)		7C	ADR5 Serbus
8A	Reserved	8B	DTR	DTE	8C	GND
9A	Reserved	9B	CTS	DTE	9C	ADR4 Serbus
10A	GND	10B	TXD	DTE	10C	Reserved
11A	Reserved	11B	RTS	DTE	11C	Reserved
12A	GND	12B	RXD	DTE	12C	Reserved
13A	Reserved	13B	DSR	DTE	13C	Reserved
14A	GND	14B	DCD	DTE	14C	Reserved
15A	Reserved	15B	Power failure (break contact)		15C	Reserved
16A	GND	16B			16C	+ 12 V (across 100 kΩ)

2.3.4 MESSAGES Connector

Inscription: MESSAGES X12

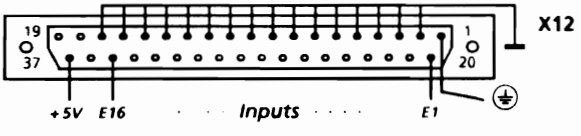

1	Screen (ground)	20	Free
2	Free	21	Message 1
3	Message 1	22	Message 2
4	Message 2	23	Message 3
5	Message 3	24	Message 4
6	Message 4	25	Message 5
7	Message 5	26	Message 6
8	Message 6	27	Message 7
9	Message 7	28	Message 8
10	Message 8	29	Message 9
11	Message 9	30	Message 10
12	Message 10	31	Message 11
13	Message 11	32	Message 12
14	Message 12	33	Message 13
15	Message 13	34	Message 14
16	Message 14	35	Message 15
17	Message 15	36	Message 16
18	Message 16	37	Message power failure
19	Message power failure		

The power failure message (break contact) is issued only on the DMC01 whereas for the DMC01C this message is available at X11 of the power supply.

DMC01 - DMC01C Preparation for Use

2.4 Modification for Use as Bench Model or Rackmount (Design 90)

Tools required: Phillips screwdriver size 2

2.4.1 Bench Model

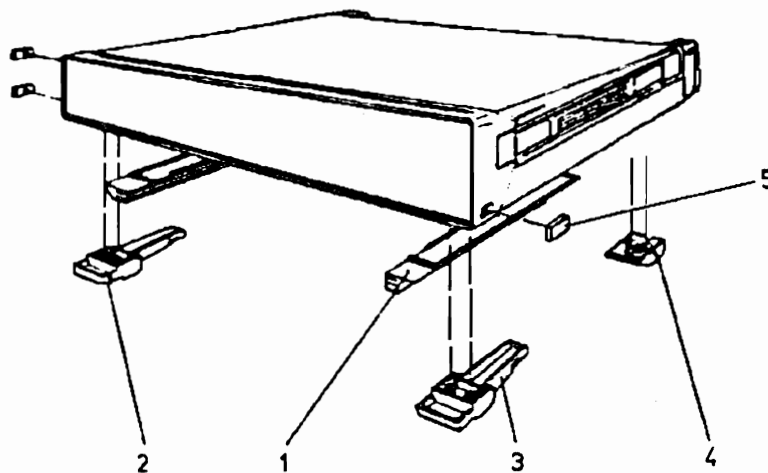

- ▶ Insert the guide rails (1) at the rear and snap into place from the outside to the inside.
- ▶ Press the front feet (2) with the foldback feet (3) into the cover and lock.
- ▶ Press the rear feet (4) into the cover and lock.
- ▶ Press the 4 lateral feet (5) in.

2.4.2 Rackmount

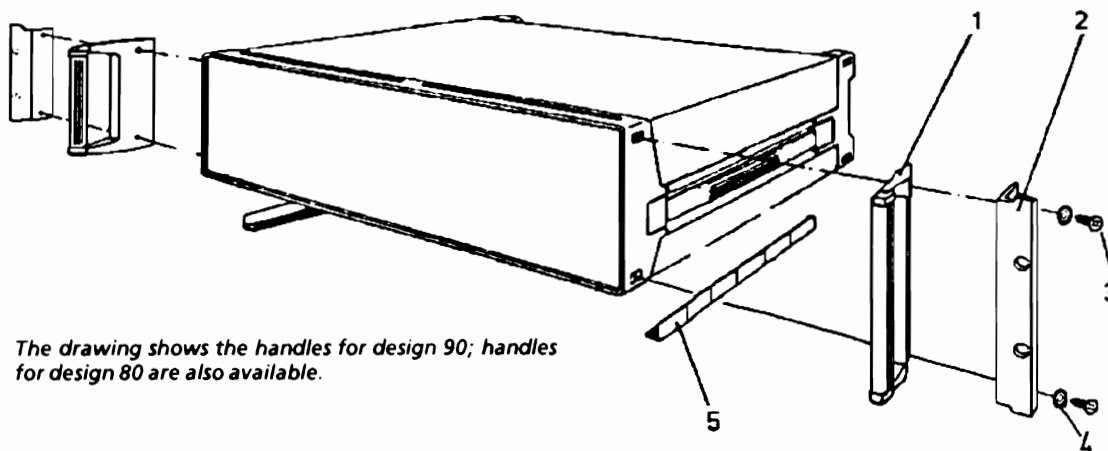

The drawing shows the handles for design 90; handles for design 80 are also available.

- ▶ Fix the handles (1) and brackets (2) with screws (3) and lock washers (4).
- ▶ Remove the protective paper from the guide rails (5).
- ▶ Stick the guide rails to the bottom of the device (surface to be glued at bottom and not on the side).

DMC01 - DMC01C Preparation for Use

2.5 Installation of DMC01C Plug-in

Tools required: Phillips screwdriver size 2

2.5.1 Installing the Plug-in into the Subrack

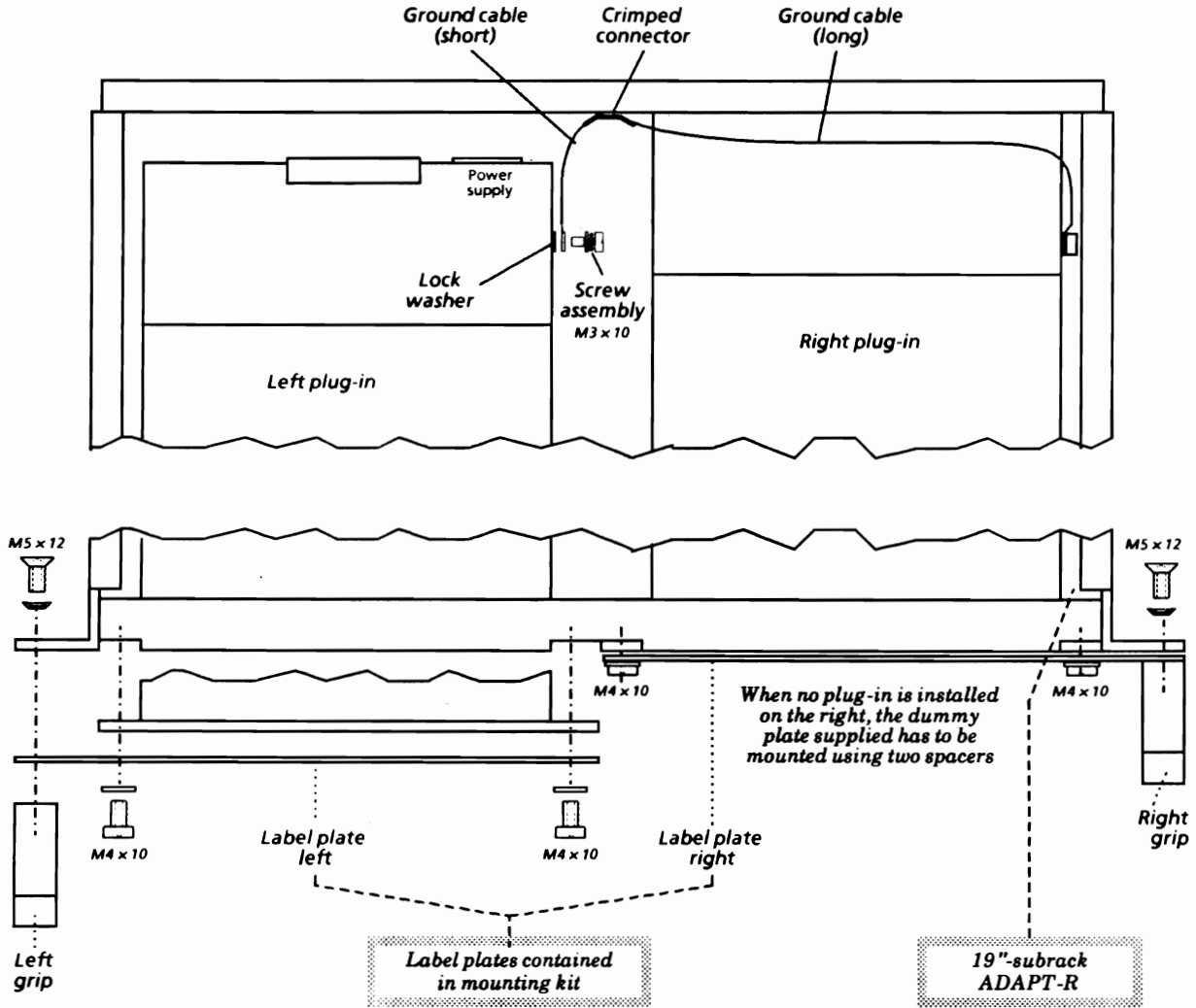

Tools required

Phillips screwdriver size 2, flat pliers

Preparing the plug-in

Fix ground cable (short with lefthand plug-in, long with righthand plug-in) with screw assembly (M3x10, with washers) to power supply thereby inserting a lock washer between soldering tag and thread of power supply.

Installation of plug-in

Insert plug-in from the front into the subrack. Power supply and subrack connector (X11) have to fit into the cut-outs at the rear panel. The front panel of the plug-in has to be flush with the lefthand or righthand bracket of the subrack.

Ground cable

Connect ground cables to the crimped connector at the rear panel of the subrack.

Fixing of plug-in

Fix label plate together with plug-in with one screw (M4x10) and washer each at the left and right (note different design of lefthand and righthand plug-in). Before screwing down align label plate to upper and lower edge of subrack.

DMC01 - DMC01C Preparation for Use

Mounting the dummy plate When no plug-in is installed on the right, the dummy plate supplied has to be mounted using two spacers. To this end use two screws with a washer each.

Fixing the handles Insert the handles in the cut-outs of the anti-twist label plate and screw down from the rear with countersunk-head screws (M5x12) using special lock washers.

2.5.2 Installing the Subrack into a 19" Rack

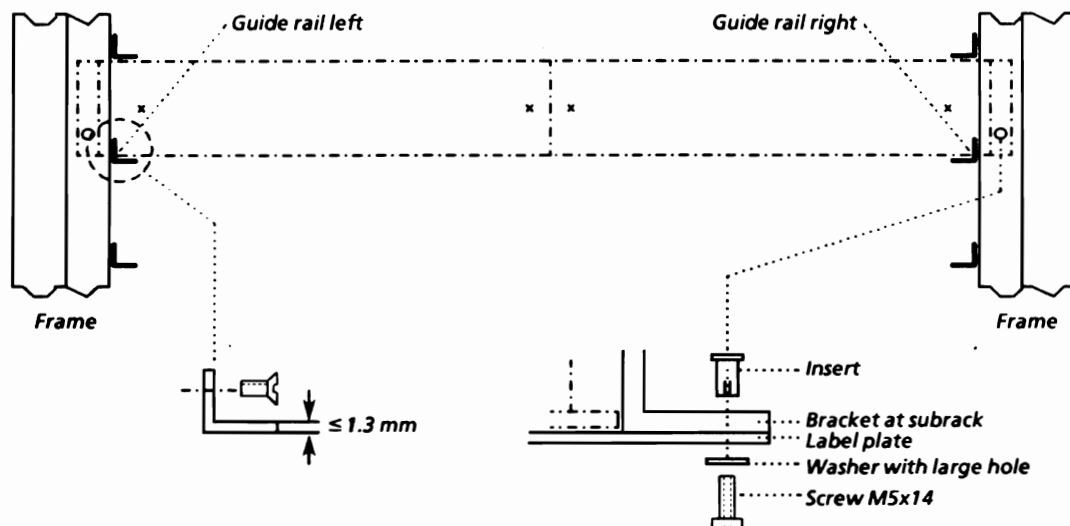

Tools required

Phillips screwdriver size 2

Preparation

For mounting the captive screws push in the two inserts from the rear into the holes of the two brackets at the left- and righthand side of the subrack. Slip on the special washers (large hole) on the protruding collar and tighten screws (M5x14).

Mounting the guide rails

The guide rails are to be fixed in the desired position inside the rack on the left and right using screws with countersunk head. The horizontal part of the guide rail must not exceed 1.3 mm in thickness.

Installation

Insert subrack into the rack and fix with captive screws to the frames. Make the connections at the rear. Fix power supply in position.

Junction panel

A junction panel for system integration can be supplied. Install it at the guide rails with brackets. Align junction panel with mounted subrack.

3 Operating Instructions

3.1 Legend for Front and Rear

3.1.1 DMC01 Rackmount

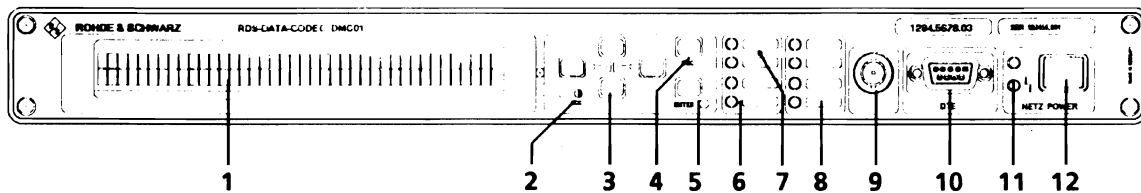

Fig. 3-1 Front view of DMC01 rackmount

No.	Inscription	Function
1	---	LCD Two lines with 40 characters each (ASCII character set)
2	LCD	Contrast control for LCD (1) (normally adjustment is not required)
3		a) Keys for moving the cursor within the menu windows b) Adjustment (flashing value; cursor up/down)
4	ESC	a) Leaving a submenu (going to the next higher menu level) b) Termination of adjustment without modifying the current value
5	ENTER	a) Branching to a submenu (going to the next lower menu level) b) Confirmation of modified value
6	CODER WARNING PILOT TA EON-TA EON-TP	Coder messages Synchronization failure, eg because pilot is missing (LED, yellow) Pilot present (LED, green) TA and/or EON-TA enabled (LED, green) EON-TP enabled (LED, green)
7	---	Reset key (accessible through hole in the front panel) Cold start: press briefly for <1 s Warm start. press for >2 s
8	DECODER ↓ SYNC LIMIT TA EON-TA LINK	Decoder messages Synchronization failure, eg because pilot is missing(LED, yellow) Device switches to internal generation of 57-kHz subcarrier Limit values exceeded (LED, yellow) TA and/or EON-TA present (LED, green) Link mode = data link switched on (LED, green)
9	57kHz (+ MPX) x9	Test output Same level as main output BNC female (unbalanced)
10	DTE x9	Serial connector , eg for terminal Sub-D male, 9-contact (DTE = data terminal equipment)
11		All operating voltages within rated range (LED, green) Fault of operating voltage (LED, red)
12	POWER	Power switch

DMC01- DMC01C Operating Instructions

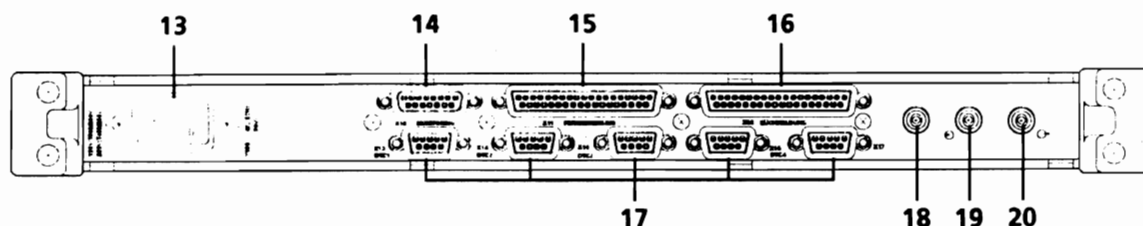

Fig. 3-2 Rear view of DMC01 rackmount

No.	Inscription	Function
13	100 ... 240 V X100	Power connector AC supply range 100 to 240 V (limits: 88 to 264 V)
14	MONITORING X10	Connector for monitoring equipment Sub-D female, 15-contact; for contact assignment see Section 2.3.
15	REMOTE CONTROL X11	Connector for operating commands TTL inputs with pullup resistors Sub-D female, 37-contact; for contact assignment see Section 2.3.
16	MESSAGES X12	Connectors for messages Floating signalling contacts Sub-D female, 37-contact; for contact assignment see Section 2.3.
17	DTE1 ... DTE5 X13 X14 X15 X16 X17	Serial interface Sub-D male, 9-contact (DTE = data terminal equipment) <i>Note: Upon power up, a warm or a cold start, DTE5 is set to a fixed preset data format: EBU protocol, 9600 baud, 8 data bits, 1 stop bit, no parity (9600/8/1/N)</i>
18	SYNC / MPX X6	Main input a) Pilot (squarewave with TTL level or sinewave signal) or b) MPX signal (with pilot but without 57-kHz subcarrier (RDS/VRF)) Triax panel connector, series 0 (balanced) or BNC female (floating)
19	MPX - DEC. X8	Decoder input a) MPX signal with RDS signal and pilot b) RDS signal, possibly with VRF signal (57-kHz subcarrier) Triax panel connector, series 0 (balanced) or BNC female (floating)
20	57 kHz (+ MPX) X7	Main output a) RDS signal possibly with VRF signal (for addition in stereocoder) b) Complete MPX + RDS/VRF signal (for modulating the transmitter) Level adjustable by way of menu or commands Triax panel connector, series 0 (balanced) or BNC female (floating)

Assignment of serial interfaces of DMC01 rackmount (for standard software version)			
Interface	Connector	Position	Interface function
DTE1	X13	Rear panel	Coder (link or EBU protocol)
DTE2	X14	Rear panel	Coder (link or EBU protocol)
DTE3	X15	Rear panel	Decoder (terminal or link protocol) or coder (link or EBU protocol)
DTE4	X16	Rear panel	Coder (link or EBU protocol)
DTE5	X17	Rear panel	Coder default interface (EBU protocol after cold or warm start); flash memory update
DTE	X3	Front panel	Coder (link or EBU protocol)

DMC01- DMC01C Operating Instructions

3.1.2 DMC01C Plug-in

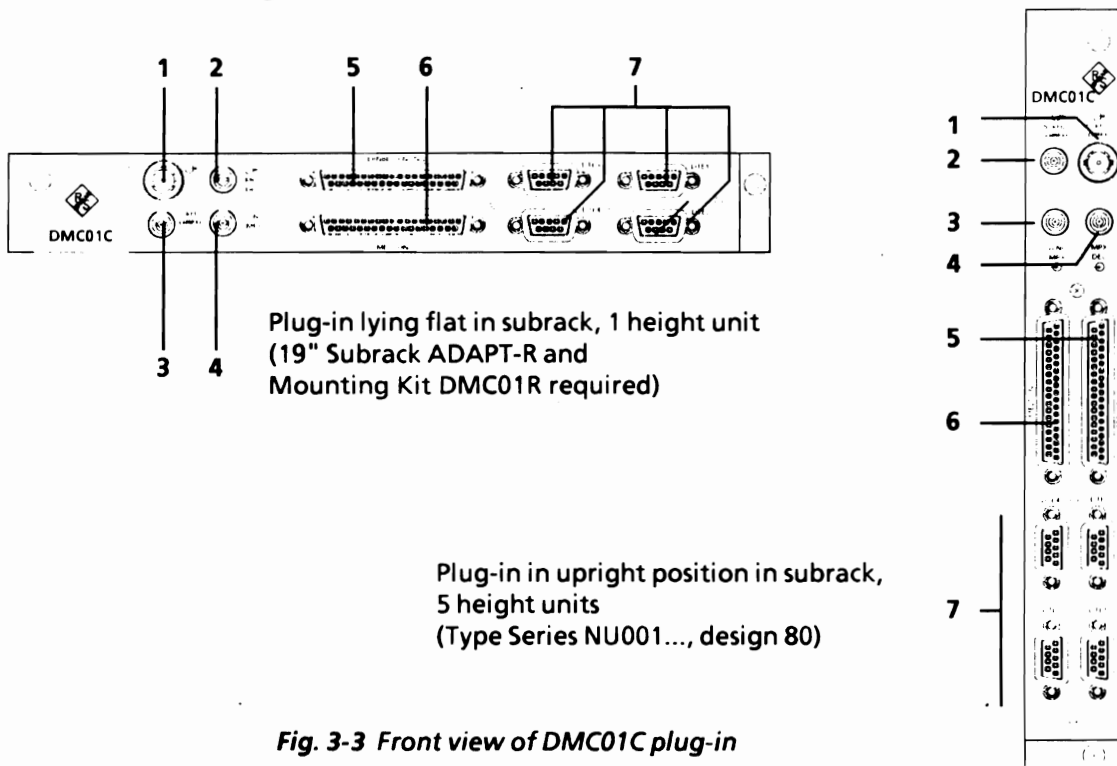

Fig. 3-3 Front view of DMC01C plug-in

No.	Inscription	Function
1	57kHz (+ MPX) X9	Monitoring output Same signal and same level as main output; BNC female (unbalanced)
2	MPX - DEC. X8	Decoder input a) MPX signal with RDS signal and pilot b) RDS signal, possibly with VRF signal (57-kHz subcarrier) Triax panel connector, series 0 (balanced) or BNC female (floating)
3	57 kHz (+ MPX) X7	Main output a) RDS signal possibly with VRF signal (for addition in stereocoder) b) Complete MPX + RDS/VRF signal (for modulating the transmitter) Level adjustable by way of commands Triax panel connector, series 0 (balanced) or BNC female (floating)
4	SYNC / MPX X6	Main input a) Pilot (squarewave with TTL level or sinewave signal) or b) MPX signal (with pilot but without 57-kHz subcarrier (RDS/VRF)) Triax panel connector, series 0 (balanced) or BNC female (floating)
5	REMOTE CONTROL X11	Connector for operating commands TTL inputs with pullup resistors Sub-D female, 37-contact; for contact assignment see Section 2.3.
6	MESSAGES X12	Connector for messages Floating signalling contacts Sub-D female, 37-contact; for contact assignment see Section 2.3.
7	DTE1 ... DTE4 X13 X14 X15 X17	Serial interfaces Sub-D male, 9-contact (DTE = data terminal equipment) <i>Note: Upon power up, a warm or a cold start, DTE5 is set to a fixed preset data format: EBU protocol, 9600 baud, 8 data bits, 1 stop bit, no parity (9600/8/1/N)</i>

DMC01- DMC01C Operating Instructions

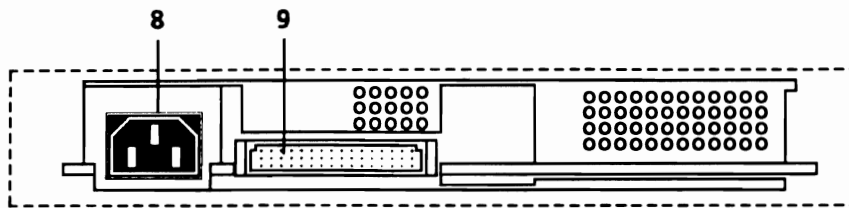

Fig. 3-4 Rear view of DMC01C plug-in

No.	Inscription	Function
8	100 ... 240 V X100	Power connector AC supply range 100 to 240 V (limits: 88 to 264 V)
9	X11 (on power supply)	Rack connector Fault message of power supply; DTE interface; for contact assignment see Section 2.3.

Assignment of serial interfaces of DMC01 rackmount (for standard software version)

Interface	Connector	Position	Interface function
DTE1	X13	Front panel	Coder (link or EBU protocol)
DTE2	X14	Front panel	Coder (link or EBU protocol)
DTE3	X15	Front panel	Decoder (terminal or link protocol) or coder (link or EBU protocol)
DTE4	X17	Front panel	Coder default interface (EBU protocol after cold or warm start); flash memory update
DTE	X11	Rear panel (on power supply)	Coder (link or EBU protocol)

DMC01- DMC01C Operating Instructions

3.2 Overview

The operational capability depends on the software used (in the flash memory) and on the hardware version (DMC01 rackmount with Display or DMC01C plug-in).

The software is of modular design so that, depending on the application, only parts thereof or special software packages can be implemented.

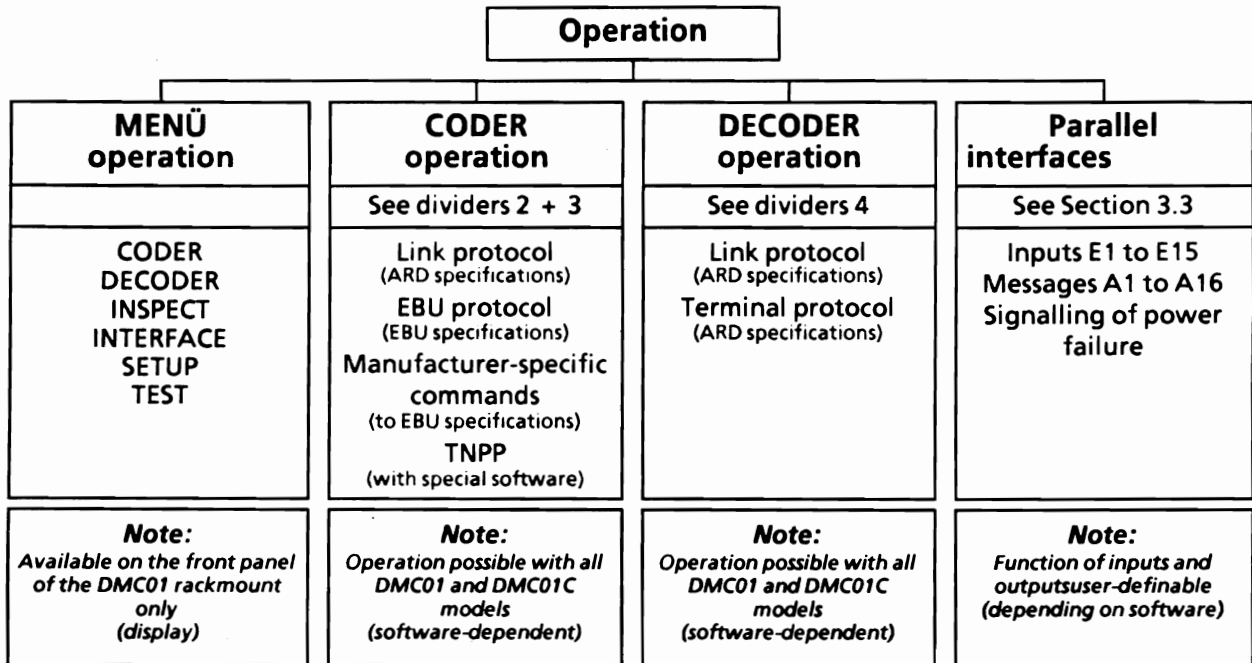

DMC01 rackmount

The DMC01 rackmount is fitted with front-panel controls and with serial interfaces. Thus it can be operated both by way of the menu and via the serial interfaces.

- ▶ Operation from the front panel
Keys on the front panel of the DMC01 rackmount enable the selection of all switching functions, level settings and displays. The menu functions can be indicated on the alpha-numeric display. LED indicators signal special settings and alarms.
- ▶ All interface functions (same parallel and serial interfaces as with DMC01C plug-in)
- ▶ Monitoring connector (data stream)

DMC01C plug-in

As the DMC01C plug-in has neither a display nor any keys, it can be operated only via the interfaces.

- ▶ Operation of coder section
Commands via serial interfaces (special features on customer's request)
- ▶ Operation of decoder section
Commands via serial interfaces (special features on customer's request)
- ▶ Remote control
Control by closing loop to ground
- ▶ Messages
via floating relay contacts (one make contact per function)
- ▶ Rack connector for integration into systems

Special features on customer's request
*Special features, eg paging or other services, can be implemented on request.
 Like with an update, the required firmware is loaded into the flash memory.
 It is possible to define new interface functions.
 These software packages are described in separate manuals or in the
 relevant standard specifications.*

3.3 Interfaces

For contact assignment see Section 2.3.

3.3.1 Serial Interfaces

For RDS data input and output, six serial interfaces are provided on the DMC01 rackmount and five on the DMC01C plug-in.

Use of serial interfaces	
Configuration	See Section 2.1.5
Contact assignment	See Section 2.3.1
Location	See Section 3.1

Transmission modes

RS-232-C

All interfaces are designed as DTE (= data terminal equipment) with hardware handshake (RTS - CTS). To activate the interface, lines DTR (pin 4) and RTS (pin 7) must be ON (positive potential). This hardware handshake can be disconnected by way of the software.

RS-485

The interfaces X13 (DTE1) and X14 (DTE2) are prepared for RS-485 transmission with the appropriate software.

Coder interfaces

The serial coder interfaces can be operated by means of the link protocol or the EBU protocol.

The transmission format can be set via the software for 300 to 19,200 baud, 8 bits, no parity, 1 stop bit.

It is possible to modify the RDS data in all data sets. The commands consist of ASCII character strings. In addition, a checksum is transmitted to allow detection of transmission errors.

Decoder interface

The serial decoder interface can be operated by means of the terminal protocol or the link protocol. These protocols also contain the necessary switchover commands.

The transmission format can be set as for the coder.

Default interface

This serial interface is used for configuring the device, eg the other serial interfaces. After a warm start (eg power off/on) the default interface takes up a defined transmission format (9600/8/N/1) and thus allows the entry of commands irrespective of the device configuration.

It is possible to enter commands in accordance with the EBU and the manufacturer-specific protocols, the latter also meeting the specifications of the EBU protocol.

In addition this interface can be operated with the aid of the flashup software. For the software update the interface is automatically switched to the relevant flashup protocol and then switched back again.

A transmission format of 9600 baud, 8 bits, no parity, 1 stop bit is set.

3.3.2 Monitoring Interface

Coder monitoring

For test purposes the data stream for the RDS modulator is available with TTL levels at the monitoring connector.

The clock (1187.5 Hz) is obtained by dividing the frequency of the 57-kHz RDS signal and has a duty cycle of 2:1. The data are transferred with the negative-going edge of the clock signal.

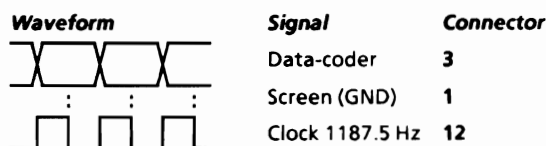

Decoder monitoring

For test purposes the data stream from the RDS decoder is available with TTL levels at the monitoring connector. The data are transferred with the positive-going edge of the clock signal.

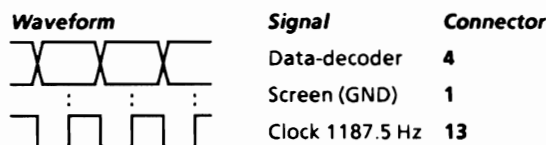

DMC01- DMC01C Operating Instructions

3.3.3 REMOTE CONTROL Interface

X11 REMOTE CONTROL

Depending on the software, different functions can be assigned to the inputs. This assignment can be defined and modified by the user. The floppy coming with the device allows certain basic settings to be made.

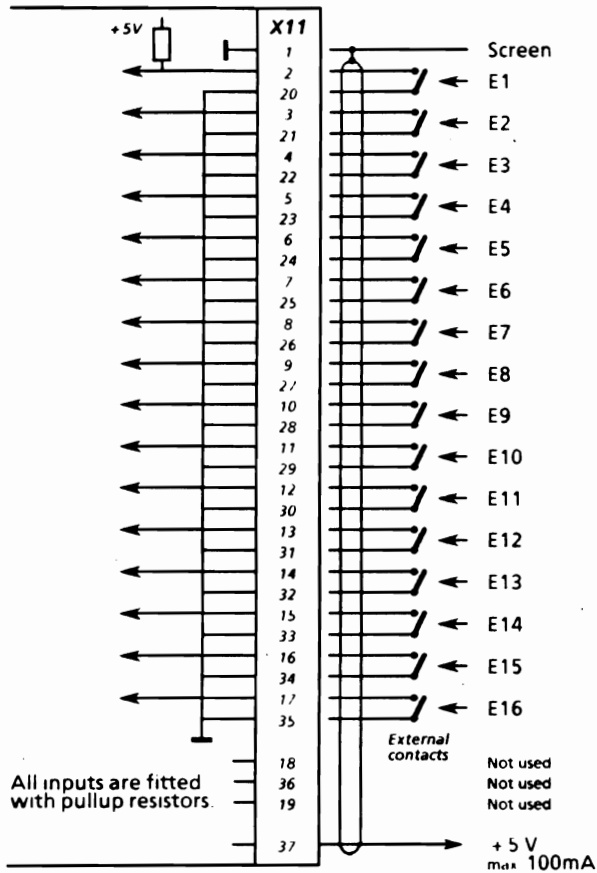

3.3.4 MESSAGES Interface

X12 MESSAGES

Depending on the software, different functions can be assigned to the outputs. This assignment can be defined and modified by the user. The floppy coming with the device allows certain basic settings to be made.

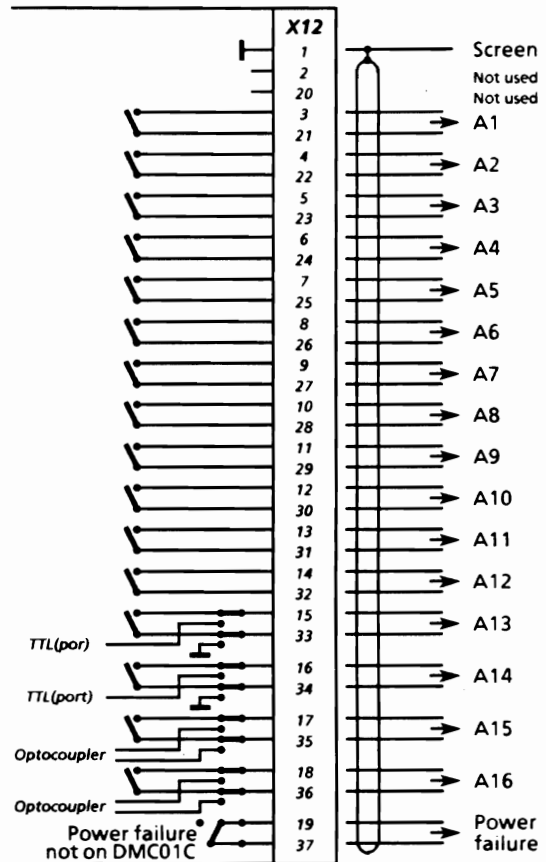

Reference Table

Configuration of serial interfaces

DMC01 rackmount

Interface	Function
DTE	Protocol: <input type="checkbox"/> Coder <input type="checkbox"/> Decoder <input type="checkbox"/> Link <input type="checkbox"/> Terminal <input type="checkbox"/> EBU <input type="checkbox"/> Type: RS-232-C Baud rate baud
DTE1	Protocol: <input type="checkbox"/> Coder <input type="checkbox"/> Decoder <input type="checkbox"/> Link <input type="checkbox"/> Terminal <input type="checkbox"/> EBU <input type="checkbox"/> <input type="checkbox"/> RS232C <input type="checkbox"/> RS485 Type Baud rate baud
DTE2	Protocol: <input type="checkbox"/> Coder <input type="checkbox"/> Decoder <input type="checkbox"/> Link <input type="checkbox"/> Terminal <input type="checkbox"/> EBU <input type="checkbox"/> Type: <input type="checkbox"/> RS232C <input type="checkbox"/> RS485 Baud rate baud
DTE3	Protocol: <input type="checkbox"/> Coder <input type="checkbox"/> Decoder <input type="checkbox"/> Link <input type="checkbox"/> Terminal <input type="checkbox"/> EBU <input type="checkbox"/> Type: RS-232-C Baud rate baud
DTE4	Protocol: <input type="checkbox"/> Coder <input type="checkbox"/> Decoder <input type="checkbox"/> Link <input type="checkbox"/> Terminal <input type="checkbox"/> EBU <input type="checkbox"/> Type: RS-232-C Baud rate baud
DTE5	Protocol: <input type="checkbox"/> Coder <input type="checkbox"/> Decoder <input type="checkbox"/> Link <input type="checkbox"/> Terminal <input type="checkbox"/> EBU <input type="checkbox"/> Type: RS-232-C Baud rate 9600 baud Special feature: <input checked="" type="checkbox"/> Flashup interface <input checked="" type="checkbox"/> Default
Handshake	on all interfaces: <input type="checkbox"/> Hardware <input type="checkbox"/> Off

Configuration of parallel interfaces

Output assignment of MESSAGES interface (X12)

Output	Function
A1	
A2	
A3	
A4	
A5	
A6	
A7	
A8	
A9	
A10	
A11	
A12	
A13	
A14	
A15	
A16	
AC-FAIL	Power failure message on DMC01

Input assignment of REMOTE CONTROL interface (X11)

Input	Function
E1	
E2	
E3	
E4	
E5	
E6	
E7	
E8	
E9	
E10	
E11	
E12	
E13	
E14	
E15	
E16	

DMC01C plug-in

Interface	Function
DTE	Protocol: Type: RS232C With special software and cables only
DTE1	Protocol: <input type="checkbox"/> Coder <input type="checkbox"/> Decoder <input type="checkbox"/> Link <input type="checkbox"/> Terminal <input type="checkbox"/> EBU <input type="checkbox"/> Type: <input type="checkbox"/> RS-232-C <input type="checkbox"/> RS485 Baud rate baud
DTE2	Protocol: <input type="checkbox"/> Coder <input type="checkbox"/> Decoder <input type="checkbox"/> Link <input type="checkbox"/> Terminal <input type="checkbox"/> EBU <input type="checkbox"/> Type: <input type="checkbox"/> RS-232-C <input type="checkbox"/> RS485 Baud rate baud
DTE3	Protocol: <input type="checkbox"/> Coder <input type="checkbox"/> Decoder <input type="checkbox"/> Link <input type="checkbox"/> Terminal <input type="checkbox"/> EBU <input type="checkbox"/> Type: RS232C Baud rate baud
DTE4	Protocol: <input type="checkbox"/> Coder <input type="checkbox"/> Decoder <input type="checkbox"/> Link <input type="checkbox"/> Terminal <input type="checkbox"/> EBU <input type="checkbox"/> Type: RS232C Baud rate 9600 baud Besonderheit: <input checked="" type="checkbox"/> Flash pro <input checked="" type="checkbox"/> Default
Handshake	On all interfaces: <input type="checkbox"/> Hardware <input type="checkbox"/> Off





ROHDE & SCHWARZ

Communications
Division

Operating Manual

Software

Link Protocol for Coder

RDS CODEC

DMC01 and DMC01C

Printed in the Federal
Republic of Germany

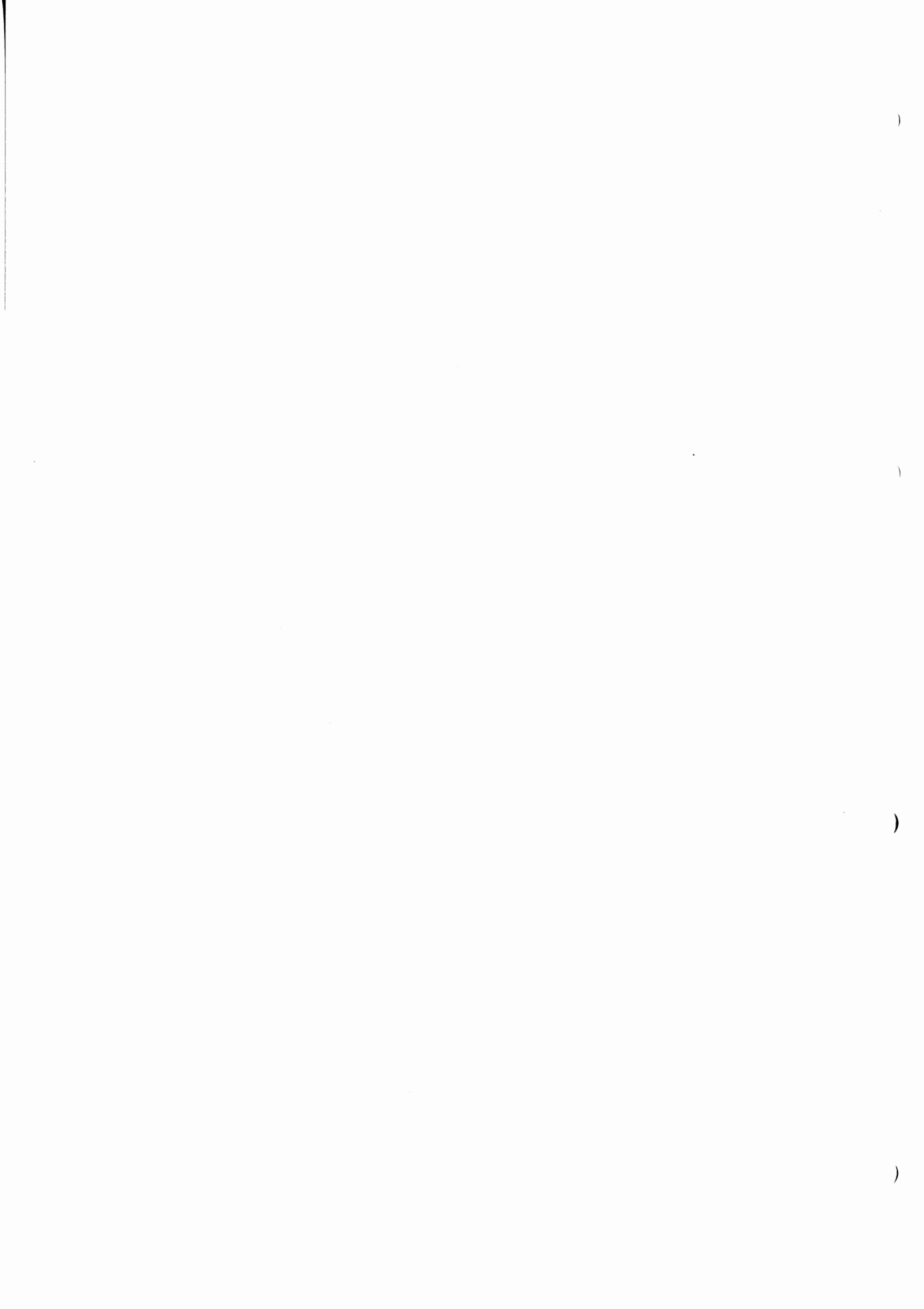

CONTENTS

1	Summary		
1.1	Command structure		5
1.2	Checksum		5
Fig. 1	Syntax		5
1.3	Command abbreviations (IK)		6
1.4	Data evaluation - Delimiter		6
1.5	Return messages		6
2	List of all defined commands		
	Standard commands		7
	EON commands		7
	Group commands		8
	Special commands		8
3	Message Description		
3.1	Standard Commands		9
	Send data sets	IK: y	9
	Group Sequence GR	IK: z	9
	Copy data sets	IK: c	9
	Program Identification PI	IK: d	9
	Program Service Name PS	IK: e	9
	Radiotext RT	IK: f	10
	Alternative Frequencies AF	IK: g	10
	Traffic Program TP	IK: h	11
	Traffic Announcement TA	IK: i	11
	Music/Speech MS	IK: j	11
	Program Type PTY	IK: k	11
	Decoder Information DI	IK: l	11
	Program Item Number PIN	IK: m	12
	Clock / Time CT	IK: n	12
	Inhouse Information IH	IK: p	12
3.2	EON Commands		13
	EON Program service name PS(ON)	IK: Ee	13
	EON Alternative Frequencies AF(ON) AF version A	IK: Ef	13
	EON Alternative Frequencies AF(ON) AF version A	IK: Eg	13
	Extended generic indicator EG	IK: Ed	13
	Linkage actuator LA	IK: Er	13
	Linkage number LN	IK: Eq	14
	EON Program type PTY(ON)	IK: Ek	14
	EON Traffic program TP(ON)	IK: Eh	14
	EON Traffic announcement TA(ON)	IK: Ei	14
	EON Program item number PIN(ON)	IK: Em	14
	EON Inhouse information IH(ON)	IK: Ep	14
	EON User code 10 AC10(ON)	IK: EA	14
	EON User code 11 AC11(ON)	IK: EB	15
	EON User code 12 AC12(ON)	IK: EC	15
	EON User code 13 AC13(ON)	IK: ED	15
	EON User code AC(ON)	IK: EG	15

**Operation Coder DMC01(C)
Link Protocol**

3.3	Group Commands		16
	Group 1A	IK: 1z	16
	Group 1B	IK: Hz	16
	Group 3A	IK: 3z	16
	Group 3B	IK: Jz	16
	Group 4A	IK: 4z	16
	Group 4B	IK: Kz	17
	Group 5A	IK: 5z	17
	Group 5B	IK: Lz	17
	Other groups		17
3.4	Special Commands		18
	EWS functions	IK: :	18
4	Link Protocol		
Table 1:	Commands for serial interfaces		19

The following commands allow the entry of RDS data in abbreviated form (no dialog mode), eg from a computer (PC) or an RDS decoder. Commands and data are written and transmitted in ASCII. Basically the command syntax is the same for all information handled.

The link protocol complies with specifications No. 5/3.8, part I (basic unit), of the broadcasting corporations under public law in the Federal Republic of Germany.

1 Introduction

1.1 Command Structure

Each command is composed of the command abbreviation (IK), a parameter part and the data. For easy recognition of data-transmission errors, each command is preceded by a 2-digit checksum. A command is terminated with the ASCII characters "ETX" or "FS" or cancelled with "CAN".

The data transmitted with a command are treated differently depending on this delimiter (see data evaluation).

With some RDS information (eg radiotext) the entire command is divided up into subcommands that are transmitted one after the other. These subcommands also have a checksum and are terminated with the ASCII character "RS" to indicate that more of the command is still to come. The subcommands are decoded and the data buffered. Only the last subcommand is terminated with "ETX" or "FS" and after this all the data entered are processed and stored.

The ASCII character "ACK", "NAK" or "CAN" is output after each command or subcommand, according to whether the command is correct or false (see return messages). Wait for the "ACK" or "NAK" acknowledgement after each command or subcommand before entering a new command or subcommand.

The checksum is followed by one or two ASCII characters as a command abbreviation and to indicate the data set to which the following data relate. If "X" is entered as the data set, all data sets are addressed. "0" means the data set currently being transmitted.

1.2 Checksum

A checksum P is computed before each command or subcommand and transmitted as a 2-byte checksum P1 and P2. For computing the checksum, first all decimal values of the ASCII characters of a command, including end-of-text characters, are summed and the total mod 65536 is calculated. Then the result P is split into two bytes P1 and P2 for transmission. P1 is transmitted before P2, and both can have a value of up to 255.

The following equations are used:

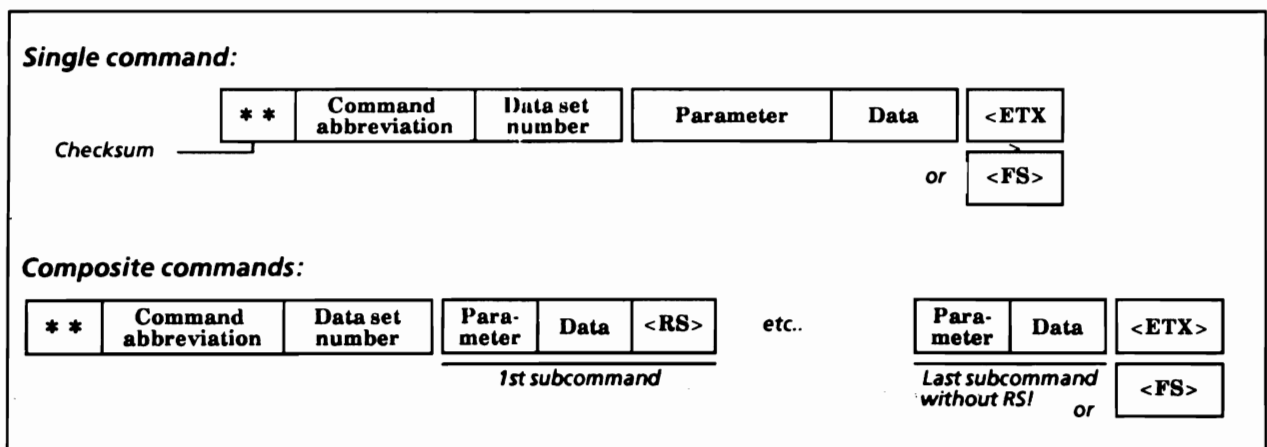

Fig. 1 Syntax

$$P = \left(\sum_{n=1}^K \text{decimal equivalents of ASCII characters} \right) \text{ mod } 65536$$

$$P = 256 \times P1 + P2$$

$$P1 = \text{INT}(P/256) \quad P2 = P \text{ mod } 256$$

Example:

Entry of a new PI code

```

** d 1 AAAA <ETX>
** =          checksum P1 and P2
d1AAAA =     command for PI code in data set 1
<ETX> =      delimiter
    
```

ASCII characters	Decimal values
d	100
1	49
A	65
A	65
A	65
A	65
<ETX>	03
Sum:	P = 412

$$P1 = \text{INT}(412 / 256) = 1, \text{ remainder } 156 \rightarrow P1 = 1$$

$$P2 = 412 \text{ mod } 256 = 156 \rightarrow P2 = 156$$

Calculation:

P1	P2	Calculated checksum
1	156	Checksum decimal
0	1	Checksum hex
9	C	

1.3 Command Abbreviations (IK)

The checksum is followed by the command abbreviation ("IK") identifying the kind of entry.

1.4 Data Evaluation - Delimiter

After entry of a command or a number of sub-commands and termination with "ETX" or "FS", the transmitted data are processed.

Termination with "FS" means that only the data in the addressed data set are altered, the transmitted data remaining unaltered.

Termination with "ETX" means that the entry (like with "FS") in the addressed data set is altered if and only this data are copied into the retrieval buffer and transmitted.

1.5 Return Messages

The device determines any transmission errors or syntax errors with the checksum and the parameters and will produce a corresponding message. "ACK" is signalled for error-free entries, otherwise "NAK". The return message is output after each command or subcommand. You should always wait for the ACK or NAK message after each entry before moving on to the next entry.

An "NAK" message can mean a transmission error on the line, incorrect checksum calculation or a syntax error. In composite commands the logical sequence of the subcommands is also checked. For the first "NAK", the last command or subcommand entered has to be repeated. If it was a transmission error, an "ACK" will very likely then be signalled. A second "NAK" means that there is another error however, and the DMC switches the interface back to the basic mode. Parts of the information that has been entered may then be thrown out, but the content of the data sets remains unaltered. In this case enter the entire command again. This is important for features like radiotext with several parts. If you have already entered four radiotexts without error, for instance, and an "NAK" message appears with the fifth radiotext, repeat the fifth text. A second "NAK" message will throw out all texts, so you have to start again with the command parameters and the first text.

Other acknowledgements are issued to indicate completed transmission to the memory:

- command RT,
- command IH,
- all commands which include a "z" as the second letter of the command abbreviation (1A/1B, 3A/B to 15A)

The acknowledgement is output at the interfaces where entry of the information is authorized.

The acknowledgement CAN is output if there is no access priority.

Examples:

- p1B** IH data channel 27 hex (27 dec.) transmitted
- f** All radiotexts transmitted

2 List of all defined commands

The commands and their abbreviations are listed below:

Standard commands

Information	Function	Command abbreviation "IK"	Parameter and data
DS	Transmission of data set	y	0 send actual data set (DS) again 1 ... 8 transmit DS1 ... DS8 9 send data set for startup
GR	Group sequence	z	<1st group> <2nd group> ...
Copy	Copy data sets	c	
PI	Program identification	d	<DS> AAAA
PS	Program service name	e	<DS> <Text>
RT	Radiotext	f	<DS> <block repetition rate> <text repetition rate> <text> Text = <number of texts to follow> <text 1> <text 2> ...
AF	Alternative frequencies	g	<DS> <number of lists> <list 1> <list 2> ... List = <number of frequencies> <EBU code frequency 1> ...
TP	Traffic program	h	<DS> 0/1 0 = off, 1 = on
TA	Traffic announcement	i	<DS> 0/1 0 = off, 1 = on
MS	Music/speech	j	<DS> 0/1 0 = speech, 1 = music
DI	Decoder information	j	<DS> <EBU code for DI in hex>
PTY	Program type	k	<DS> <EBU code for PTY in hex.>
PIN	Program item number	m	<DS> <EBU code for PIN in hex.>
CT	Clock/Time	n	<DS> <EBU code for CT in hex.>
IH	Inhouse information	p	<DS> <Number of informations> <Info 1> <Info 2> ... Info = <repetition rate> <channel> <data>

EON commands

Information	Function	Command abbreviation "IK"	Parameter and data
PS(ON)	EON program service name	Ee	<DS> <PI code> <name>
AF(ON)	EON alternative frequencies AF version A AF version B	Ef Eg	<DS> <PI code> <number of Frequ.> <frequency code 1> ... <DS> <PI code> <number of lists> <list 1> <list 2> ...
EG	Extended generic indicator	Ed	<DS> <PI code> <1/0>
LA	Linkage actuator	Er	<DS> <PI code> <1/0>
LN	Linkage number	Eq	<DS> <PI code> <linkage number>
PTY(ON)	EON program type	Ek	<DS> <PI-Code> <program type>
TP(ON)	EON traffic program	Eh	<DS> <PI code> <1/0>
TA(ON)	EON traffic announcement	Ei	<DS> <PI code> <1/0>
PIN(ON)	EON program item number	Em	<DS> <PI code> <information>
IH(ON)	EON inhouse information	Ep	<DS> <PI code> <information>
AC10(ON)	EON user code 10	EA	<DS> <PI code> <information>
AC11(ON)	EON user code 11	EB	<DS> <PI code> <information>
AC12(ON)	EON user code 12	EC	<DS> <PI code> <information>
AC13(ON)	EON user code 13	ED	<DS> <PI code> <information>
AC(ON)	EON user code	EG	<DS> <PI code> <information>

IK = Command abbreviation

<DS> = Number of data set

**Operation Coder DMC01(C)
Link Protocol**

Group commands

Information	Function	Command abbreviation "IK"	Parameter and data
1A	Group 1A	1z	
1B	Group 1B	H _z	
3A	Group 3A	3z	<repetition rate> <number of infos> <info 1> <info 2> ... (10 Byte / Information)
3B	Group 3B	J _z	<repetition rate> <number of infos> <info 1> <info 2> ... (6 Byte / Information)
4A	Group 4A	4z	see group 3A
4B	Group 4B	K _z	see group 3B
5A	Group 5A	5z	see group 3A
5B	Group 5B	L _z	see group 3B
7B	Group 7B	N _z	see group 3B
8A	Group 8A	8z	see group 3A
8B	Group 8B	0z	see group 3B
9A	Group 9A	9z	see group 3A
9B	Group 9B	P _z	see group 3B
10A	Group 10A	A _z	see group 3A
10B	Group 10B	Q _z	see group 3B
11A	Group 11A	B _z	see group 3A
11B	Group 11B	R _z	see group 3B
12A	Group 12A	C _z	see group 3A
12B	Group 12B	S _z	see group 3B
13A	Group 13A	D _z	see group 3A
13B	Group 13B	T _z	see group 3B
15A	Group 15A	F _z	see group 3A

Special commands

Information	Function	Command abbreviation "IK"	Parameter and data
	EWS functions	:	

IK = Command abbreviation

<DS> = Number of data set

3 Message Description

3.1 Standard Commands

Below there is a brief explanation of the command with an example or examples for each kind of information. See capture 1.

Any data set (DS) 1 through 8 can be entered, or 0, X and 9.

Data set 0 = data set currently being sent,
Data set 1 = data set number 1
usw.
Data set 8 = data set number 8
Data set 9 = startup data set (DSIB)
Data set X = all data sets 1 to 8

Abbreviations:

** - represents the checksum
- means a space
ETX command delimiter, optionally
FS ETX = 03 hex, FS = 1C hex
RS separator or delimiter for
 subcommand, RS = 1E hex

The following command examples are all terminated with FS.

Send data sets IK: y

Syntax:
**** y <DS> <FS>**

Example:
**** y 0 <FS>** Send data set again
**** y 1 <FS>** Send data set 1
**** y 8 <FS>** Send data set 8
**** y 9 <FS>** Send data set for startup

y = Command abbreviation (IK) for send data set.
0 = Data set number
<FS> = command delimiter

Note: When a data set is sent, a previously entered, new group sequence becomes active at the same time.

Group Sequence GR IK: z

Syntax:
**** z <1st group> <2nd group> ... <FS>**

Example:
**** z 0A1A5A0A6A <FS>**
Entry of new group sequence 0A, 1A, 5A, 0A, 6A. A maximum of 36 groups are possible.

Note:
The group sequence is defined without the data sets because the sequence applies to all data sets.

Copy data sets IK: c

Copy specific data set into startup data set.
Syntax:

**** c <DS-Quelle> <FS>**

Example:
**** c3 <ETX>**
Copying data set number 3 into startup data set.
<ETX> = command delimiter

Program Identification PI IK: d

Syntax:
**** d <DS> 0|1 <FS>**

Example:
**** d 1 AAAA <FS>**
Entry of PI code for data set 1.
AAAA = PI code in hex
<FS> = command delimiter

Program Service Name PS IK: e

Syntax:
**** e <DS> <Text> <FS>**

Example:
**** e 2 _SDR_3_ <FS>**
Entry of PS code for data set 2.
_SDR_3_ = PS code (ASCII characters)
<FS> = command delimiter

Operation Coder DMC01(C)
Link Protocol

Radiotext RT	IK: f	Alternative Frequencies AF	IK: g
<p>Syntax: ** y <DS> <block repetition rate> <number of texte> <text repetition rate> <text 1> <RS> <text repetition rate> <text 2> <RS> ... <text repetition rate> <text n> (without RS!) <FS></p> <p>1st example: one radiotext</p> <p>** f 4 00 3 1 XXXXX <FS> Entry of RT information in data set 4.</p> <p>00 = text block repetition rate in hex (range 00-FF, 00 = constant transmission)</p> <p>3 = text repetition rate in hex (range 1-8)</p> <p>1 = one radiotext to follow in hex</p> <p>XXXXX = radiotext (max. 64 ASCII characters)</p> <p>2nd example: three radiotexts</p> <p>** f 1 FF 8 3 XXXX <RS> Entry of three radiotexts in data set 1.</p> <p>FF = text block repetition rate in hex (range 00-FF, 00 = constant transmission)</p> <p>8 = single text repetition rate in hex (range 1-8)</p> <p>3 = three radiotexts to follow (max. eight radiotexts)</p> <p>XXXX = first radiotext (max. 64 ASCII characters)</p> <p><RS> = delimiter for first text, further texts to follow</p> <p>** YYYY <RS> Entry of second text.</p> <p>YYYY = second radiotext (max. 64 ASCII characters)</p> <p><RS> = delimiter for second text, further texts to follow</p> <p>** ZZZZ <FS> Entry of third text.</p> <p>ZZZZ = third and last radiotext (max. 64 ASCII characters)</p> <p><FS> = delimiter for third and last text</p> <p>Note: <i>Each of the texts is transmitted eight times; the text block 255 times.</i></p>		<p>Note: <i>EBU codes see appendix</i></p> <p>Table 1: EBU hex code for number of frequencies in list</p> <p>Table 2/3: EBU hex code for frequencies</p> <p>Syntax: ** y <DS> <number of lists> List 1: <Code for number of frequencies> <Frequency 1> <Frequency 2> ... <RS> List 2: <Code for number of frequencies> <Frequency 1> <Frequency 2> ... <RS> ... List n: <Code for number of frequencies> <Frequency 1> <Frequency 2> (without RS!) <FS></p> <p>1st example: one AF list</p> <p>** g 1 01 E4 19270C89 <FS> Entry of AF list with four AFs in data set 1.</p> <p>01 = number of lists in hex (max. 28 hex)</p> <p>E4 = EBU hex code for number of frequencies in list (E4 = four frequencies to follow)</p> <p>19270C89 = EBU codes (hex) for AFs</p> <p><FS> = command delimiter</p> <p>2nd example: two AF lists</p> <p>** g 1 02 E2 0102 <RS> Entry of first AF list with two AFs in data set 1.</p> <p>02 = number of lists in hex (max. 28 hex)</p> <p>E2 = EBU code for number of frequencies in list in hex (E2 = two frequencies to follow)</p> <p>0102 = EBU codes for AFs in hex</p> <p><RS> = delimiter for first list, another list to follow</p> <p>** E3 04050A <FS> Second list starts straight away with EBU number code.</p> <p>E3 = EBU code for number of frequencies in list in hex (E3 = three frequencies to follow)</p> <p>04050A = EBU codes (hex) for AFs</p> <p><FS> = delimiter of last list</p>	

**Operation Coder DMC01(C)
Link Protocol**

3rd example:

AF list with offset frequency and MW frequency

**** g 1 01 E3 FD 19 FA 10 01 <FS>**

Entry of AF list with three AFs in data set 1.

- 01 = number of lists in hex (max. 28 hex)
- E3 = EBU code for number of frequencies in list in hex (E3 = three frequencies to follow)
- FD = EBU code (hex) for 25-kHz offset
- 19 = EBU code for frequency 90.0 MHz hex
- FA = EBU code (hex) for MW frequency
- 10 = EBU code (hex) for frequency 531 kHz
- 01 = EBU code (hex) for frequency 87.6 MHz

4th example:

no AF lists

**** g 1 00 <FS>**

AF lists are deleted in data set 1.

<FS> = delimiter

Traffic Program TP

IK: h

Syntax:

**** h <DS> 0|1 <FS>**

Example:

**** h 3 1 <FS>**

Set TP in data set 3.

**** h 3 0 <FS>**

Disable TP in data set 3.

Traffic Announcement TA

IK: i

Syntax:

**** i <DS> 0|1 <FS>**

Example:

**** i 4 1 <FS>**

Set TA in data set 4.

**** i 4 0 <FS>**

Disable TA in data set 4.

Music/Speech MS

IK: j

Syntax:

**** j <DS> 0|1 <FS>**

Example:

**** j 7 1 <FS>**

Set MS bit in data set 7 to music.

**** j 7 0 <FS>**

Set MS bit in data set 7 to speech.

Program Type PTY

IK: k

Syntax:

**** k <DS> <PTY information> <FS>**

Example:

**** k 1 00 <FS>**

Set PTY information in data set 1 to 00. EBU code (hex) for PTY

**** k 1 1E <FS>**

Set PTY information in data set 1 to 30 (= 1E hex).

<FS> = delimiter

Program Type

00	No program type or undefined
01	NEWS
02	AFFAIRES
03	INFO
04	SPORT
05	EDUCATE
06	DRAMA
07	CULTURE
08	SCIENCE
09	VARIED
0A	POP M
0B	ROCK M
0C	M.O.R.M
0D	LIGHT M
0E	CLASSICS
0F	OTHER M
10 to 1D	Not yet assigned
1F	Alarm

Decoder Information DI

IK: l

Syntax:

**** l <DS> <switching information> <FS>**

Example:

**** l X 1 <FS>**

Set DI information in all data sets to 1.

1 = EBU code for stereo in hex (range 0-F)

**** l X F <FS>**

Set DI information in all data sets to 15 (= F hex).

Operating information for the receiver decoder:

0	Mono
1	Stereo
2	Not yet assigned
3	Stereo dummy head
4	Mono compressed
5	Stereo compressed
6	Not yet assigned
7	Stereo compressed (dummy head)
8 to F	Not yet assigned

Operation Coder DMC01(C)
Link Protocol

Program Item Number PIN **IK: m**

Syntax:

**** m <DS> <PIN information> <FS>**

Example:

**** m 1 715E <FS>**

Set PIN information in data set 1 to 14th day, 5.30.

715E = EBU code in hex

715E hex = 01110 00101 011110 binary
day 14 hour 5 minutes 30

<FS> = command delimiter

Note:

The entered time must already be coded to EBU and entered as a hexadecimal number.

Clock I Time CT **IK: n**

Syntax:

**** n X <CT information> <FS>**

Example:

**** n X 168D6DA28 <FS>**

Entry of CT information.

CT is independent of the data set.

X = dummy variable

168D6DA28 =

EBU code hex

<FS> = command delimiter

Note:

The CT code must already be coded to EBU and contain the date (MJD) and the time (UTC + offset). In the example the date 2.5.1985 and the time 13.40, offset -8 were selected. The calculation of MJD to EBU produces a value of 46187 dec or B46B hex. Together with the time the binary pattern is then as follows:

0001 0110 1000 1101 0110 1101 1010 0010 1000
1 6 8 D 6 D A 2 8 in hex.

Note: *CT can only be switched on and off from the terminal.*

Inhouse Information IH **IK: p**

Syntax:

**** p <DS> <number of IH informations>
<repetition rate><channel><information 1>
<RS>**

**<repetition rate><channel><information 2>
<RS>**

...

<repetition rate><channel><information n>

(last input without RS!)

<FS>

1st example:

one item of IH information

**** p 3 01 0 1E AAAAAAAAA <FS>**

Entry of one item of IH information in data set 3.

01 = number (hex) of IH information items (range 00 to 20)

0 = repetition rate in hex (range 0 to F, 0 = constant transmission)

1E = channel number (hex) of entered IH data (range 00 to 1F, 1E = channel 30)

AAAAAAAA =

IH information in hex

(4 hex characters in group type B or 8 hex characters in group type A)

2nd example:

three items of IH information

**** p 3 03 F 0A AAAAAAAAA <RS>**

Entry of three items of IH information in data set 3.

03 = number (hex) of IH information items (range 00 to 20)

F = repetition rate in hex (range 0 to F, 0 = constant transmission)

0A = channel number (hex) of entered IH data (range 00 to 1F, 0A = channel 10)

AAAAAAAA =

IH information in hex (max. eight hex digits)

<RS> = delimiter for first IH information item, further data to follow

**** 8 0B BBBBBBBBB <RS>**

Entry of second IH information item.

8 = repetition rate in hex (range 0 to F, 0 = constant transmission)

0B = channel number (hex) of entered IH data (range 00 to 1F, 0B = channel 11)

BBBBBBBB =

IH information in hex

(max. eight digits)

<RS> = delimiter for second IH information item, further data to follow

**** 0 0C CCCCCCCC <FS>**

Entry of third IH information item.

0 = repetition rate in hex (range 0-F, 0 = constant transmission)

0C = channel number (hex) of entered IH data (range 00 to 1F, 0C = channel 12)

CCCCCCCC =

IH information in hex

(max. eight hex digits)

<FS> = delimiter for third IH information item, no IH information to follow

3.2 EON Commands

EON Program service name PS(ON) IK: Ee

Syntax:

**** Ee <DS> <PI code> <name> <FS>**

Example:

**** Ee 3 D681 NDR_1_HH**

D681 = PI code

3 = Data set

NDR_1_HH

Name

<FS> = Command delimiter

EON Alternative Frequencies AF(ON) Ef

Syntax:

**** Ef <DS> <PI code>**
<number of frequencies>
<frequency 1> <frequency 2> ...
<FS>

Example:

**** Ef 1 D681 E46E62**

1 = Data set 1

D681 = PI code

E4 = Code for Frequency 1

6E = Code for Frequency 2

62 = Code for Frequency 3

<FS> = Command delimiter

Syntax for delete:

**** Ef <DS> <PI-Code> <FS>**

Deletes the EON-AF liste of the specified data set with the specified PI.

EON Alternative Frequencies AF(ON) Eg

Syntax:

**** Eg <DS> <PI code> <number of lists>**
List 1: *<number of frequencies>*
<frequency 1> <frequency 2> ...<RS>
List 2: *<number of frequencies>*
<frequency 1> <frequency 2> ...<RS>
 ...
List n: *<number of frequencies>*
<frequency 1> <frequency 2> .. (without RS1)
<FS>

Example:

**** Eg 1 D681 03 146E<RS>**

**** 0962 <RS> ** 4375 <FS>**

1 = Data set 1

D681 = PI code

03 = 3 lists to follow

146E = Frequency codes of 1st list

0962 = Frequency codes der 2nd list

4375 = Frequency codes der 3rd list

<RS> = Delimiter

<FS> = Command delimiter

Syntax for delete:

**** Eg <DS> <PI-Code> <FS>**

Deletes the EON-AF liste of the specified data set with the specified PI.

Extended generic indicator EG IK: Ed

Syntax:

**** Ed <DS> <PI code> <0/1> <FS>**

Example:

**** Ed 1 D681 0<FS>**

1 = Data set 1

D681 = PI code

1 = Extended generic indicator

(0 = not extended)

AC = 12, bit m₁₄

<FS> = Command delimiter

Linkage actuator LA IK: Er

Syntax:

**** Er <DS> <PI code> <0/1> <FS>**

Example:

**** Er 1 D681 1**

1 = Data set 1

D681 = PI code

1 = Linkage actuator on (0 = off)

AC = 12, bit m₁₅

<FS> = Command delimiter

Note:

The LA bit (group 1A, block 3) must be set (LA = 1)

Operation Coder DMC01(C)
Link Protocol

Linkage number LN IK: **Eq**

Syntax:

**** Eq <DS> <PI code>**
<Linkage number> <FS>

Example:

**** Eq 1 D681 03C1**
1 = Data set 1
D681 = PI code
03C1 = Linkage number
 AC = 13, bit m₁₂ ... m₀₀
 first character:
 0 = national; 1 = international
<FS> = Command delimiter

EON Program type PTY(ON) IK: **Ek**

Syntax:

**** Ek <DS> <PI code> <Programtype> <FS>**

Example:

**** Ek 1 D681 01**
1 = Data set 1
D681 = PI code
01 = Programtype (see table)
<FS> = Command delimiter

Program type

00	No program type or undefined
01	NEWS
02	AFFAIRES
03	INFO
04	SPORT
05	EDUCATE
06	DRAMA
07	CULTURE
08	SCIENCE
09	VARIED
0A	POP M
0B	ROCK M
0C	M.O.R.M
0D	LIGHT M
0E	CLASSICS
0F	OTHER M
10 to 1D	Not yet assigned
1F	Alarm

EON Traffic program TP(ON) IK: **Eh**

Syntax:

**** Eh <DS> <0/1> <FS>**

Example:

**** Eh D681 1**
D681 = PI-Code
1 = EON traffic program on
 (0 = off)
<FS> = Command delimiter

EON Traffic announcement TA(ON) IK: **Ei**

Syntax:

**** Ei <DS> <PI code> <0/1> <FS>**

Example:

**** Ei 1 D681 1**
1 = Data set 1
D681 = PI code
1 = EON traffic announcement on
 (0 = off)

EON Program item number PIN(ON) IK: **Em**

Syntax:

**** Em <DS> <PI code> <information> <FS>**

Example:

**** Em 1 D681 715E**
1 = Data set 1
D681 = PI code
715E = EBU code for PIN
<FS> = Command delimiter
715E hex = 01110 00101 011110 binary
 day 15 hour 5 minutes 30

Note:

The entered time must already be coded to EBU and entered as a hexadecimal number.

EON Inhouse information IH(ON) IK: **Ep**

Syntax:

**** Ep <DS> <PI code> <information> <FS>**

Example:

**** Ep 1 D681 AF01**
1 = Data set 1
D681 = PI code
AF01 = IH information
 range 0000 to 1FE00 hex
 FFFF = all EON IH are deleted at the PI code
<FS> = Command delimiter

EON User code 10 AC10(ON) IK: **EA**

Syntax:

**** EA <DS> <PI code> <information> <FS>**

Example:

**** EA 3 D681 3333 <FS>**
D681 = PI code
3 = Data set 3
3333 = Set all free bits in group 14B, block 3 to
 3333 (range 0000 to 1FFF hex)
<FS> = Command delimiter

**Operation Coder DMC01(C)
Link Protocol**

EON User code 11 AC11(ON) IK: EB

Syntax:
**** EB <DS> <PI code> <information> <FS>**

Example:
**** EB 1 D681 3333 <FS>**
D681 = PI code
1 = Data set 1
3333 = Set all free bits in group 14B, block 3 to
 3333 (range 0000 to 1FFF hex)
<FS> = Command delimiter

EON User code 12 AC12(ON) IK: EC

Syntax:
**** EC <DS> <PI code> <information> <FS>**

Example:
**** EG 2 D681 6 <FS>**
D681 = PI code
1 = Data set 2
6 = Bit m_{13} in group 14B, Block 3 is set to 6
 hex. (range 0 to 7 hex)
<FS> = Command delimiter

Note:
The LA bit (group 1A, block 3) must be set (LA = 1)

EON User code 13 AC13(ON) IK: ED

Syntax:
**** ED <DS> <PI code>**
 <bits m_{10} to m_{01} > <FS>

Example:
**** ED 1 D681 222 <FS>**
D681 = PI code
1 = Data set 1
222 = Bits m_{10} to m_{01} in group 14B, Block 3
 are set to 222 hex. (range 000 to 3FF
 hex)
<FS> = Command delimiter

Note:
The LA bit (group 1A, block 3) must be set (LA = 1)

EON User code AC(ON) IK: EG

Syntax:
**** ED <DS> <PI code>**
 <3 bits> <FS>

Example:
**** ED 1 D681 222 <FS>**
D681 = PI code
1 = Data set 1
4 = Bits are set to 4 hex. (range 0 to F hex)
<FS> = Command delimiter

3.3 Group Commands

Group 1A IK: 1z

Syntax:

**** 1z** <priority> <user code>
 <information> <FS>

Example:

**** 1z 1 5 6 123**
F = priority
 0 = no transmission
 1 = high priority
 F = transmitted once
 (range 0 to F hex)
5 = user code
 block 3, bits m₁₄ to m₁₂
 (range 0 to 7 hex)
123 = information (3 bytes)
 block 3, bits m₁₁ ... m₀₀
 (range 000 to FFF hex)
<FS> = command delimiter

Group 1B IK: Hz

Transmission in group 1B, block 2.

Syntax:

**** Hz** <block repetition rate>
 <number od informations>
 <information 1> <RS>
 <information 2> <RS>
 ...
 <information n> <FS>

Example:

**** Hz F 03 06 <RS> ** 06 <RS> ** 05 <FS>**
F = block repetition rate
 (range 0 to F hex)
03 = number od informations
 (range 01 to 40 hex)
06 = information 1 (2 bytes)
 (range 00 to 1F hex)
06 = information 2 (2 bytes)
 (range 00 to 1F hex)
06 = information 3 (2 bytes)
 (range 00 to 1F hex)
<RS> = delimiter
<FS> = command delimiter

Group 3A IK: 3z

Syntax:

**** 3z** <repetition rate>
 <number od informations>
 <information 1> <RS>

<information 2> <RS>
...
<information n> (without RS!)
<FS>

Example:

**** 3z D 02 0123456789 <RS>**
**** 0F0F0F0F0F <FS>**
D = repetition rate
 (range 0 to F hex)
02 = number od informations
 (range 01 to 40 hex)
02 0123456789 =
 information 1 (10 bytes)
 (range 0000000000 to 1FFFFFFFFF hex)
<RS> = delimiter
0F0F0F0F0F =
 information 2 (10 bytes)
<FS> = command delimiter

Group 3B IK: Jz

Syntax:

**** Jz** <block repetition rate>
 <number od informations>
 <information 1> <RS>
 <information 2> <RS>
 ...
 <information n> (kein RS!)
 <FS>

Example:

**** Jz D 02 012345 <RS> ** 0F0F0F <FS>**
D = block repetition rate
 (range 0 to F hex)
02 = number of informations
 (range 01 to 40 hex)
02 0123456789 =
 Information 1 (10 bytes)
 (range 0000000000 to 1FFFFFFFFF hex)
0F0F0F0F0F =
 information 2
<RS> = delimiter
<FS> = command delimiter

Group 4A IK: 4z

Syntax:

**** 4z** <block repetition rate>
 <number of informations>
 <information> <FS>

Example:

**** 4z 1 0C 123456701357 <FS>**
1 = block repetition rate
 (range 0 to F hex)
0C = number of informations (0C = 12 dez)
 (range 01 to 40 hex)

**Operation Coder DMC01(C)
Link Protocol**

123456701357 =
 informations
 (1 byte / information)
 (range 0 to 7 hex)
 <FS> command delimiter

<RS> delimiter
 FFFF0000 =
 Information 2 (8 Bytes)
 (range 00 to 1F hex)
 <FS> command delimiter

Group 4B IK: Kz

Transmission of 3 free bits in group 4B, block4.

Syntax:

**** Kz** <Block repetition rate >
 <number of informations >
 <Information 1 > <RS>
 <Information 2 > <RS>
 ...
 <Information n > <FS>

Example:

**** Kz 3 02 123456 <RS> 0ABCDE<FS>**
 3 = block repetition rate
 (range 0 to F hex)
 02 = number of informations
 (range 01 to 40 hex)
 123456 = information 1 (6 bytes)
 (Ber. 00 to 1F hex)
 <RS> delimiter
 0ABCDE = information 2 (6 bytes)
 (range 00 to 1F hex)
 <FS> command delimiter

Group 5A IK: 5z

Transmission of 4 bytes in group 5A, block3 and 4 bytes in block 4

Syntax:

**** 5z** <Block repetition rate >
 <channel >
 <number of informations >
 <Information 1 > <RS>
 <Information 2 > <RS>
 ...
 <Information n > <FS>

Example:

**** 5z 1 1C 02 12345678 <RS> ** FFFF0000 <FS>**
 1 = Block repetition rate
 (range 0 to F hex)
 1C = channel
 (range 01 to 31 hex)
 02 = number of informations
 (range 01 to 40 hex)
 12345678 =
 Information 1 (8 Bytes)
 (range 00 to 1F hex)

Group 5B IK: Lz

Transmission of 4 signs in group 5B, block4.

Syntax:

**** 5z** <Block repetition rate >
 <channel >
 <number of informations >
 <Information 1 > <RS>
 <Information 2 > <RS>
 ...
 <Information n > <FS>

Example:

**** 5z 1 1C 02 123456 <RS> ** FFF000 <FS>**
 1 = Block repetition rate
 (range 0 to F hex)
 1C = channel
 (range 01 to 31 hex)
 02 = number of informations
 (range 01 to 40 hex)
 123456 = information 1 (4 bytes)
 (range 00 to 1F hex)
 <RS> delimiter
 FFF000 = information 2 (4 bytes)
 (range 00 to 1F hex)
 <FS> command delimiter

Other groups

Group	Command abbreviation "IK"	
7B	Nz	see group 3B
8A	8z	see group 3A
8B	Oz	see group 3B
9A	9z	see group 3A
9B	Pz	see group 3B (used for EWS)
10A	Az	see group 3A
10B	Qz	see group 3B
11A	Bz	see group 3A
11B	Rz	see group 3B
12A	Cz	see group 3A
12B	Sz	see group 3B
13A	Dz	see group 3A
13B	Tz	see group 3B
15A	Fz	see group 3A

3.4 Special Commands

EWS functions

IK: :

The purpose of the warning and information system EWS (Emergency Warning System) is to warn the population when a major disaster occurs. The information is processed in a host computer and fed into the RDS coder. For the command format, see section 2.5.

The EWS function requires group 1A, block 3, and group 9A. With the command abbreviation "1", only set 3 of group 9A can be modified, whereas the command abbreviation "9" allows the entire group 9A to be changed.

Alarm-mode for EWS transmission

Before transmission of the EWS information, set the RDS coder into the alarm-mode. Then transmit the EWS information in groupe 1A (AC = 7).

Alarm-mode ON:

**** : AL_ON <ETX>**

Only AC (user code) = 7
is transmitted.

Alarm-mode OFF:

**** : AL_OFF <ETX>**

All ACs (user codes) = 0 to 7 can
be transmitted.

Blocking EWS transmission

If you need no transmission of EWS, although EWS is present on the RDS coder, you can block EWS completely

Suppress User code 7 (AC7):

**** : GR1A_ON <EXT>**

All ACs (user codes) = 0 to 6 can be
transmitted, AC = 7 is blocked..

Enable User code 7

**** : GR1A_OFF <EXT>**

All ACs (user codes) = 0 to 7 can
be transmitted.

Readout

Program type PTY and Group sequence GR

Readout and store the values of Programmtype PTY and Group sequence GR before changing. Then transmit the EWS informations.

For using EWS set PTY = 31 (= alarm) and change the Group sequence GR.

After finishing EWS restore the old values of Programmtype PTY and Group sequence GR

Readout Programmtype PTY

**** : k_OUT <EXT>**

result p.e.:

: k03 03 = dec. value for PTY (00 to 31)

Readout Group sequence GR

**** : z_OUT <EXT>**

result p.e.:

: z0001093131

= Group sequence 0A,1A,9A,15B,15B
The groups have always 2 digits.
group ≤ 15 are A groups (0A to 15A),
groups ≥ 16 sind B groups (0B to 15B).
p.e. group 0A = 00; group 0B = 16,
group 15B = 31).

4 Link Protocol

The link protocol complies with specifications No. 5/3.8, part I (basic unit), of the broadcasting corporations under public law in the Federal Republic of Germany.

Table 1: Commands for serial interfaces

Standard commands

Information	Commands				Explanation	Example
	IK	DS	Extn	Range		
AF	g	1A	2A + n * (m * 2A)	\$00 to 40 \$00 to FF	Number of AF lists n (n = 0: no AF list) (m = number of AF, 2-32) AF codes EN 50 067	**g303E32C016C**E56C012C3958' **E7017B58BC25954#"
BV 1)	b	--	1A/2A + 2A + 1A + 2A	IK \$00 to 1F / \$FF 1 / 0 00/01/02/ 2A to 2D/03	Information items Channel 0-31 or \$FF = all channels access possible/blocked Data input	**by00103***bz00101***bd00101" **be00101***bg00101***bh00101" **bi0002D***bl00103***bj00100" **bk0012A***bm0012A***bf0012A" **bn00101***bpFF2C1***bp0002C" **bp0112A***bp0212B***bEgFF101" **bEi0012A***bEe0012A" ...
All	a	--	---	---	only extension of command BV	**ba00100"
Copy 1)	c	1A	--	DS: 0 to 8	copying a data set into the default data set	**c3"
CT	n	1A	9A	\$3FFFFFFF \$00000000	Date: MJD time: UTC + Offset: without time:	**nX168D6DA28" **nX000000000°
DI	l	1A	1A	\$0 to F	Decoder 0 to 15	**lX1"
DS	y	1A		DS: 0 to 8 / X	Selection of data set or Information 0 = transmitted data set X = all DS (not with IK = y)	**y3" see TA, DI ...
GR	z	--	n * (1A + 1A)	\$0 to F, A/B	Number of groups (1 to 36) Group and version	**z0A6A2A0A6A6A0A6A2A0A6A6A"
IH	p	1A	2A + n * (1A + 2A + 4A/8A)	\$00 to 20 \$0 to F \$00 to 1F \$0 to F	Number of IH informations How often to transmit (0 = allways) Channel 0 to 31 IH information	**pX0211E02468ACE**11F01234567"
MS	j	1A	1A	0 to 1	0 = Speech, 1 = Music	**jX1"
PI	d	1A	4A	\$1001 to FFFF		**d3D681"
PIN	m	1A	4A	\$0000 to FE00	14th day 5.30	**mX715E"
PS	e	1A	8A	EN 50 067	EN 50 067	**e3NDR 1 SH"
PTY	k	1A	2A	\$00 to 1F	Program type: 0 to 31	**kX01#
RT	f	1A	2A + A + A + n*(2A to 64A)	\$00 to FF \$1 to 8 \$1 to min. 2 EN 50 067	How often to transmit number of groups Repetition single text Number n of text Text	**fX0032 <UKW / FM - ARD - Radio text > *** <Radio - Daten - System RDS > #
TA	i	1A	1A	0 to 1	0 = off, 1 = on	**iX1"
TP	h	1A	1A	0 to 1	0 = off, 1 = on	**h31"

Explanations and notes see following page

**Operation Coder DMC01(C)
Link Protocol**

Cont. Table 1 Commands for serial interfaces

EON commands

Information	Commands				Explanation	Example
	IK	DS	Extn	Range		
AC(ON)	EG	1A	4A + [1A]	\$0 to 7	3 free bits in group 14B, block 2	**EGXD6817"
AC10(ON)	EA	1A	4A + [4A]	\$0000 to 1FFF	AC = 10: 16 free bits	**EAXD6810000"
AC11(ON)	EB	1A	4A + [4A]	\$0000 to 1FFF	AC = 11: 16 free bits	**EBXD6810000"
AC12(ON)	EC	1A	4A + [1A]	0 to 1	AC = 12: bit m ₁₃ 2)	**ECXD6810"
AC13(ON)	ED	1A	4A + [3A]	\$000 to 3FF	AC = 13: bits m ₁₀ - m ₀₁ 2)	**EDXD681000"
AF(ON)	Eg	1A	4A + [2A + n*(2A + [1-4*2A] + M + 2A)]	\$01 to 40 \$00 to FF \$00 to FF \$00 to FF	AF version B n = number of AF lists AF: Tuning frequency TN up to 4 FM codes and/or 1 AM code ("M") Input of new AF deletes all old AF for other networks in the data set	**Eg3D681" (deletes AF) **Eg2D68103146E62'**09626E' **4375" **Eg2D68103146E6275M41' **09626E M41'**4375M41
AF(ON)	Ef	1A	4A + [m*2A]	\$01 to 40	AF version A m = number of AF codes, 2 to 32	**Ef2D681E46E626775" **EfXD681" (deletes AF)
EG	Ed	1A	4A + [1A]	0 to 1	0 = not expanded, 1 = expanded AC = 12: bit m ₁₄ 2)	**EdXD6810"
EON			PI INFO	\$1001 to FFFF	Enhanced Other Networks Informations	**Ee3D681": PS(ON) deletes in DS3 for D681
IH(ON)	Ep	1A	4A + [4A]	\$0000 to 1FE00	INFO = \$FFFF deletes all EON for PI code	**EpXD681AF01" **EpXD681FFFF": deletes all EON for D681, transmit 3 times
LA	Er	1A	4A + [1A]	0 to 1	0 = off, 1 = on AC = 12: bit m ₁₅ 3) 2)	**ErXD6811"
LN	Eq	1A	4A + [4A]	\$0000 to 1FFF	\$0AAA = national, \$1AAA = intern. AC = 12: bit m ₁₂ - m ₀₀ 2)	**EqXD68103C1"
PIN(ON)	Em	1A	4A + [4A]	\$0000 to 1FE00	14th day 5.30	**EmXD681715E"
PS(ON)	Ee	1A	4A + [8A]			**Ee3D681NDR 1 HH"
PTY(ON)	Ek	1A	4A + [2A]	\$00 to 1F	Program type 0 to 31 AC = 13: bits m ₁₅ - m ₁₁ 2)	**EkXD68101"
TA(ON)	Ei	1A	4A + [1A]	0 to 1		**EiXD6810"
TP(ON)	Eh	1A	4A + [1A]	0 to 1		**EhXD6811"

Explanation:

IK	Information sign	**	Check sum to the next RS, FS or ETX
DS	Data set	'	Record Separator, RS
BV	Access Priority	#	File Separator, FS
A	Sign with 8 bits	"	End of Text, ETX
/	with commands and ranges only: means "or"	AC	User code
[]	optional parts of commands	EG	Extendet Generic Indicator
+	parts of commans are linked without separator	LA	Linkage Actuator
m, n	in column "Extn": mulitplicator (no command)	LN	Linkage Number

Notes:

- 1) Command for serial interface on the front panel in mode "Loading"
- 2) Position of bits in conjunction with the RDS specification
- 3) For PI code of the selected program: the LA bit must be set in group 1A, block 3

**Operation Coder DMC01(C)
Link Protocol**

Cont. Table 1: Commands for serial interfaces

Group commands

Information	Commands				Explanation	Example
	IK	DS	Extn	Range		
1A (block 3)	1z	1A	1A+ 1A+ 3A	\$0 to F \$0 to 7 \$000 to FFF	Priority: P = 1 high priority; P = 15 transmits once; P = 0 no transmission AC: block 3, bits m ₁₄ - m ₁₂ 2) Inform.: block 3, bits m ₁₁ - m ₀₀ 2)	**1zX56123"
1B (block 2)	H _z	--	1A+ 2A+ n * (2A)	\$0 to F \$01 to 40 \$00 to 1F	How often to transmit Number n of information items Information items group 1B, block 2	**HzF0306'"*06'"*05"
3A 3B	3z Jz	--	1A+ 2A+ n * (10A/6A)	\$0 to F \$01 to 40 \$0000000000 to 1FFFFFFFFF	How often to transmit Number n of information items n * info for one group (with version B: \$000000-1FFFFFF)	**3zD020123456789'"*0F0F0F0F"
4A	4z	--	1A+ 2A+ (nA)	\$0 to F \$01 to 40 \$0 to 7	How often to transmit Length n of information 3 bits in block 2	**4z10C123456701357"
4B	Kz	--	1A+ 2A+ n * (6A)	\$0 to F \$01 to 40 \$000000 to 1FFFFFF	How often to transmit Number n of information items n * info for one group 2/4 characters in block 2/4	**Kz302123456'0ABCDE"
5A 5B (TDC)	5z Lz	--	1A+ 2A+ 2A+ n * (8A/4A)	\$1 to F \$01 to 1F \$01 to 40 \$000000000 to FFFFFFFF	How often to transmit channel 0 to 31 Number n of information items 4 characters in block 3 and 4 (with version B: \$0000-FFFF /block 4)	**5z11C0412345678'"*FFFF0000' **87654321'"*ABCDE00"
7B	Nz	--	1A+ 2A+ n * (6A)	\$1 to F \$01 to 40 \$000000 to 1FFFFFF	How often to transmit Number n of information items n * info for one group	**Nz302123456'"*ABCDEF"
8A 8B	8z Oz	--	1A+ 2A+ n * (10A/6A)	\$1 to F \$01 to 40 \$0000000000 to FFFFFFFF	How often to transmit Number n of information items n * info for one group (with version B: \$000000-1FFFFFF)	**8z3030123456789'"*1ABCDEF123' **1FFFFFFFFF"
9A 9B (EWS)	9z Pz	--	1A+ 2A+ n * (10A/6A)	\$0 to F \$01 to 40 \$0000000000 to FFFFFFFF	How often to transmit Number n of information items n * info for one group (with version B: \$000000-1FFFFFF)	**9zF030123456789'"*1ABCDEF123' **1FFFFFFFFF"
10A 10B	Az Qz	--	1A+ 2A+ n * (10A/6A)	\$0 to F \$01 to 40 \$0000000000 to FFFFFFFF	How often to transmit Number n of information items n * info for one group (with version B: \$000000-1FFFFFF)	**Az7020123456789'"*0F0F0F0F"
11A 11B	Bz Rz	--	1A+ 2A+ n * (10A/6A)	\$0-F \$01 to 40 \$0000000000 to FFFFFFFF	How often to transmit Number n of information items n * info for one group (with version B: \$000000-1FFFFFF)	**Bz7020123456789'"*0F0F0F0F"
12A 12B	Cz Sz	--	1A+ 2A+ n * (10A/6A)	\$0 to F \$01 to 40 \$0000000000 to FFFFFFFF	How often to transmit Number n of information items n * info for one group (with version B: \$000000-1FFFFFF)	**Sz002012345'"*1FFFFFF"
13A 13B	Dz Tz	--	1A+ 2A+ n * (10A/6A)	\$0 to F \$01 to 40 \$0000000000 to FFFFFFFF	How often to transmit Number n of information items n * info for one group (with version B: \$000000-1FFFFFF)	**Dz7020123456789'"*0F0F0F0F"
15A	Fz	--	1A+ 2A+ n * (10A)	\$0 to F \$01 to 40 \$0000000000 to FFFFFFFF	How often to transmit Number n of information items n * info for one group	**Fz2030123456789'"*0000000000' **1FFFFFFFFF"

)

)

)

)



ROHDE & SCHWARZ

Communications
Division

Operating Manual

Software

Universal Encoder Communication Protocol for Coder

**RDS CODEC
DMC01 and DMC01C**

Printed in the Federal
Republic of Germany

)

)

)

)

Contents

1	Introduction	5
2	List of all Commands Defined	6
2.1	EBU Standard Commands <i>see Universal Encoder Communication Protocol</i>	6
2.2	Request Commands <i>see separate manual</i>	9
2.3	Manufacturer's Commands <i>see separate manual</i>	10
	Manufacturer's Set Commands	10
	Manufacturer's Request Commands	11
	Manufacturer's Status Commands	11
	Manufacturer's Test Commands	12

Universal Encoder Communication Protocol

Manual "Request Commands"

Manual "Manufacturer's Commands"

)

)

)

)

1 Introduction

The following commands allow the entry of RDS data in abbreviated form (no dialog mode), eg from a computer (PC) or an RDS decoder. Commands and data are written and transmitted in ASCII. The command syntax complies with the

Universal Encoder Communication Protocol.

The following commands (messages) of the EBU standard are not implemented:

Message Name	Message Element Code	Communication Protocol	Message Name	Message Element Code	Communication Protocol
EON TA control	15	page 57	TA control	2A	page 58
Message acknowledgement	18	page 64	Communication mode	2C	page 56
			PS character code table selection	2F	page 63

Note:

Data Set Number (DSN)

In the RDS Codec DMC... it is possible to provide 10 data sets which can be addressed individually. See table for the assignment.

Program Service Number (PSN)

In the EBU protocol several program service numbers (PSN) can be defined, one of the PSNs representing the main program service. The remaining PSNs may be used as EON data. In the RDS Codec DMC..., PSN 00 is assigned to the main program service. This setting cannot be varied. If a different main program service is desired, a new PSN data set must be loaded.

Data Set Number (DSN)

DSN	Target
00	Current data set
01 to 09	Specific data set
FE	All data sets except the current data set
FF	All data sets

Program Service Number (PSN)

PSN	Target
00	PSN for main service of specified data set(s)
01 ... FF	Specific service within data set(s); eg. EON

2 List of all Commands Defined

2.1 EBU Standard Commands

Function	Information	EBU Command				Parameter MED
		MIC	DSN	PSN	MEL	
Program identification	PI	01	DSN	PSN	05	1st byte: PI (MSB) 2nd byte: PI (LSB)
Program service name	PS	02	DSN	PSN	0A	<8 bytes>: PS Character 1 to 8
Traffic announcement and Traffic program bits	TA/TP	03	DSN	PSN	04	1st byte: Bit0 = TA, Bit1 = TP
Decoder information bits	DI	04	DSN	PSN	04	1st byte: DI
Music/speech switch	M/S	05	DSN	PSN	04	1st byte: Bit0 = MS
Program item number	PIN	06	DSN	PSN	05	1st byte: PIN (MSB) 2nd byte: PIN (LSB)
Programme type information	PTY	07	DSN	PSN	04	1st byte: PTY
Paging call with numeric message (10 digits)		08	---	---		1st byte: Bits 7...4: Number of repetitions; max. 15 Bits 3...0: Pager address (MSB) 2nd byte: Pager address (cont.) 3rd byte: Pager address (LSB) 4th byte: Message (first 2 digits) 5th byte: Message (second 2 digits) 6th byte: Message (third 2 digits) 7th byte: Message (fourth 2 digits) 8th byte: Message (fifth 2 digits)
Real time clock correction		09	---	---		1st byte: RTCC higher byte Hex 2nd byte: RTCC lower byte Hex
Radiotext	RT	0A	DSN	PSN		1st byte: 00 keep A/B flag 01 toggle A/B flag <max. 64 bytes>: Text character 1 to max. 64
PSN Enable/Disable		0B	DSN	---	MEL	1st byte: Bit 0: 0 disable PSN; 1 enable PSN <n bytes>: Index of PSN to be enabled or disabled
Paging call without message		0C	---	---		1st byte: Bits 7...4: Number of repetitions; max. 15 Bits 3...0: Pager address (MSB) 2nd byte: Pager address (cont.) 3rd byte: Pager address (LSB)
Real time clock	CT	0D	DSN	PSN		1st byte: Last two decimal digits of Year (as Hex) 2nd byte: Month (00...0C) 3rd byte: Date (00...1F) 4th byte: Hours (00...18) 5th byte: Minutes (00...3B) 6th byte: Seconds (00...3B) 7th byte: Centiseconds (00...63) 8th byte: Local Time offset (00...3F)
RDS level		0E	---	---		1st byte: Bits 7...4: Reference Table entry Bits 4...0: RDS level MSB 2nd byte: RDS level LSB
ARI area (BK)	ARI	0F	---	---		1st byte: 00 = off A...F = Area code A to F

**Operation Coder DMC01
EBU Protokoll**

EBU Standard Commands (cont.)

Function	Information	EBU Command				Parameter <i>MED</i>
		MEC	[DSN]	[PSN]	[MEL]	
International paging with function message		10	---	---		1st byte: Bits 7...4: Number of repetitions; max. 15 Bits 3...0: Pager address (MSB) 2nd byte: Bits 7...0: Pager address (cont.) 3rd byte: Bits 7...0: Pager address (LSB) 4th byte: Country code (2 digits) 5rd byte: Bits 7...4: Country code (1 digit) Bits 3...0: Message (character 1) 6rd byte: Message (character 2 and 3) 7rd byte: Message (character 4 and 5) 8rd byte: Message (character 6 and 7)
Paging transmitter network group designation		12	DSN	---		1st byte: 00 ... 07
	AF	13	DSN	PSN		1st byte: Start Location (High) 2nd byte: Start Location (Low) <n bytes>: AF Data Last byte: AF List terminator (00)
	EON AF	14	DSN	PSN		1st byte: Start Location (High) 2nd byte: Start Location (Low) 3rd byte: AF Data (Usage code of Group Type 14A) <n bytes>: AF Data Last byte: AF List terminator (00)
EON TA control		15	---	---		1st byte: Minimum number of groups between successive Group Type 14B (0...8) groups 2nd byte: Bits 7...4: Number of 14B groups at TA "ON" transition Bits 3...0: Number of 14B groups at TA "OFF" transition
Group sequence		16	DSN		MEL	1st byte: Bits 4...1: Group Type Bit 0: Group Version : Last byte: Nth Group Type and Version
Request message		17	---	---		see Table of "Request Commands"
Message acknowledgement		18	---	---		1st byte: Response Code 2nd byte: Sequence counter number
CT on/off		19	---	---		1st byte: 00 = off 01 = on
Slow labeling codes		1A	DSN	---		1st byte: Bits 7...4: Usage code Bits 3...0: Data (MSB) 2nd byte: Data (LSB)
Paging call with alphanumeric message (80 characters)		1B	---	---		1st byte: Message element length (4...53) 2nd byte: Bits 7...4: Number of repetitions; max. 15 Bits 3...0: Pager address (MSB) 3rd byte: Bits 7...0: Pager address (cont.) 4th byte: Bits 7...0: Pager address (LSB) 5rd byte: Message (first character) 6rd byte: Message (second character) : Last byte: Message (last 2 digits)
Data set select		1C	---	---		1st byte: Data set (01...FE)
Reference input select		1D	---	---		1st byte: Ref. Table number (01 to 06)
RDS on/off		1E	---	---		1st byte: 00 = off 01 = on
ARI level		1F	---	---		1st byte: Bits 7...4: Reference Table entry Bits 4...0: ARI level LSB 2nd byte: ARI level MSB

**Operation Coder DMC01
EBU Protokoll**

EBU Standard Commands (cont.)

Function	Information	EBU Command				Parameter MED
		MEC	[DSN]	[PSN]	[MEL]	
Paging call with numeric message (18 digits)		20	--	---		1st byte: Bits 7...4: Number of repetitions; max. 15 Bits 3...0: Pager address (MSB) 2nd byte: Pager address (cont.) 3rd byte: Pager address (LSB) 4th byte: Message (first 2 digits) 12th byte: Message (last 2 digits)
ARI on/off		21				1st byte: 00 = off 01 = on
RDS phase		22	---	---		1st byte: Bits 7...4: Reference Table entry Bits 4...0: RDS phase MSB 2nd byte: RDS phase LSB
Site address		23	---	---		1st byte: Control Bits 2nd byte: Site address high 3rd byte: Site address low
Free-format group		24	---	---		1st byte: Bits 4...1: Group Type number Bit 0: Group Type A or B 2nd byte: Block 2 (5 Bits) 3rd byte: Block 3 MSB 4th byte: Block 3 LSB 5th byte: Block 4 MSB 6th byte: Block 4 LSB
In-house information	IH	25	---	---		1st byte: 00 = Group Version A 01 = Group Version B 2nd byte: Block 2 (5 Bits) 3rd byte: Block 3 MSB 4th byte: Block 3 LSB 5th byte: Block 4 MSB 6th byte: Block 4 LSB
Transparent data channel	TDC	26	---	---		1st byte: 00 = Group Version A 01 = Group Version B 2nd byte: Channel <n bytes>: AF Data Last byte: AF List terminator (00)
Encoder address		27	---	---		1st byte: Control Bits 2nd byte: Encoder address
Make PSN list		28	DSN	---	MEL	1st byte: PSN Main service 2nd byte: PSN EON service
Group usage code sequence		29	DSN		MEL	1st byte: Bits 4...1: Group Type number Bit 0: Group Version A or B 2nd byte: First Usage code : Last byte: Nth Usage code
TA control		2A	---	---		1st byte: Minimum number of groups between successive Group Type 15B (0...8) groups 2nd byte: Bits 7...4: Number of 15B groups at TA "ON" transition Bits 3...0: Number of 15B groups at TA "OFF" transition
Emergency Warning System	EWS	2B	---	---		1st byte: Block 2 (5 Bits) 2nd byte: Block 3 MSB 3rd byte: Block 3 LSB 4th byte: Block 4 MSB 5th byte: Block 4 LSB
Communication mode		2C	---	---		1st byte: Control Bits (00, 01, 02)
Manufacturer's specific commands		2D				see Manual "Manufacturer's Specific Commands"
Linkage information	LA	2E	DSN	PSN		1st byte: Link information (MSB) 2nd byte: Link information (LSB)
PS character code table selection		2F	---	---		1st byte: Code Table number

2.2 Request Commands *see separate manual*

Function	Information	Command			Parameter
		EBU	Manufacturer		
		MELC	MEL	Code of requested message	
Request Program identification	PI	17	03	01	1st byte: Data set number (DSN) 2nd byte: Program service number (PSN) <u>Return:</u> see EBU command 01
Request Program service name	PS	17	03	02	1st byte: Data set number (DSN) 2nd byte: Program service number (PSN) <u>Return:</u> see EBU command 02
Request Traffic announcement and Traffic program bits	TA/TP	17	03	03	1st byte: Data set number (DSN) 2nd byte: Program service number (PSN) <u>Return:</u> see EBU command 03
Request Decoder information bits	DI	17	03	04	1st byte: Data set number (DSN) 2nd byte: Program service number (PSN) <u>Return:</u> see EBU command 04
Request Music/speech switch	M/S	17	03	05	1st byte: Data set number (DSN) 2nd byte: Program service number (PSN) <u>Return:</u> see EBU command 05
Request Program item number	PIN	17	03	06	1st byte: Data set number (DSN) 2nd byte: Program service number (PSN) <u>Return:</u> see EBU command 06
Request Programme type information	PTY	17	03	07	1st byte: Data set number (DSN) 2nd byte: Program service number (PSN) <u>Return:</u> see EBU command 07
Request Real time clock correction		17	01	09	<u>Return:</u> see EBU command 09
Request Radiotext	RT	17	03	0A	1st byte: Data set number (DSN) 2nd byte: Program service number (PSN) <u>Return:</u> see EBU command 0A
Request Real time clock	CT	17	02	0D	<u>Return:</u> see EBU command 0D
Request RDS level	RDS	17	01	0E	1st byte: Reference Table entry <u>Return:</u> see EBU command 0E
Request ARI area (BK)	ARI	17	01	0F	<u>Return:</u> see EBU command 0F
Request Paging transmitter network group designation		17	02	12	1st byte: Data set number (DSN) <u>Return:</u> see EBU command 12
Request Group sequence	GS	17	02	16	1st byte: Data set number (DSN) <u>Return:</u> see EBU command 16
Request Clock time and date status	CT	17	01	19	<u>Return:</u> see EBU command 19
Request Slow labelling codes		17	02	1A	1st byte: Data set number (DSN) <u>Return:</u> see EBU command 1A
Request Data set select	DS	17	01	1C	<u>Return:</u> see EBU command 1C
Request Ref. input select		17	02	1D	1st byte: Reference Table entry <u>Return:</u> see EBU command 1D
Request RDS status	RDS	17	01	1E	<u>Return:</u> see EBU command 1E
Request ARI level	ARI	17	02	1F	1st byte: Reference Table entry <u>Return:</u> see EBU command 1F

**Operation Coder DMC01
EBU Protokoll**

Request Commands (cont.)

Function	Information	Command			Parameter
		EBU	Manufacturer		
		MIC	MEL	Code of requested message	
Request ARI status	ARI	17	01	21	<u>Return:</u> see EBU command 21
Request RDS phase	RDS	17	02	22	1st byte: Reference Table entry <u>Return:</u> see EBU command 22
Request Site address		17	01	23	<u>Return:</u> see EBU command 23
Request Free-format group		17	02	24	1st byte: Bits 4...1: Group Type Bit 0: Group ver. A/B <u>Return:</u> see EBU command 24
Request In-house information	IH	17	02	25	1st byte: 00 = Group Ver. A 01 = Group Ver. B <u>Return:</u> see EBU command 25
Request Transparent data channel	TDC	17	04	26	1st byte: 02 2nd byte: 00 = Group Ver. A 01 = Group Ver. B 3rd byte: 00 ... 1F = Channel <u>Return:</u> see EBU command 26
Request Encoder address (user address)		17	01	27	<u>Return:</u> see EBU command 27
Request Group usage code sequence		17	04	29	1st byte: Data set number (DSN) 2nd byte: 01 3rd byte: Bits 4...1: Group Type Bit 0: Group ver. A/B <u>Return:</u> see EBU command 29
Request Emergency warning system	EWS	17	01	2B	<u>Return:</u> see EBU command 2B
Request Linkage information	LA	17	03	2E	1st byte: Data set number (DSN) 2nd byte: program service number (PSN) <u>Return:</u> see EBU command 2E

2.3 Manufacturer's Commands *see separate manual*

Manufacturer's Set Commands

Function	Command				Parameter
	EBU	Manufacturer			
	MIC	MEL	MEC1	MEC2	
Set VRF information DK on/off	2D	04	FE 00	<2 Bytes> 00 00 = off 00 01 = on	Parameter Parameter
Set Data mode Outgoing data: RDS or Test	2D	04	FE 01	<2 Bytes> 00 00 = RDS data 00 01 = Test data	Parameter Parameter
Set Test data	2D	0F	FE 02	<13 bytes> (13 bytes = 1 group = 104 bits)	Parameter

**Operation Coder DMC01
EBU Protokoll**

Manufacturer's Set Commands (cont.)

Function	Command			Parameter
	EBU MEC	Manufacturer MEL	MEC1 MEC2	
Set Baudrate (for serial interfaces)	2D	07	FE 03	< 5 Bytes > 1 st byte: Interface no. Parameter 2 nd byte: Baudrate Parameter 3 rd byte: parity Parameter 4 th byte: data bits Parameter 5 th byte: stop bits Parameter
Set Hardware handshake on/off (for all serial interfaces)	2D	04	FE 04	< 2 Bytes > 00 00 = handshake off Parameter 00 01 = handshake on Parameter
Set Message outputs A1 to A16 (MESSAGES / X12; relay K1 to K16)	2D	04	FE 05	< 2 Bytes > 1 st byte: output A1 to A8 (LSB = A1; MSB = A8) 2 nd byte: output A9 to A16 (LSB = A9; MSB = A16)
Set RDS/VRF phase 0°/90°	2D	04	FE 06	< 2 Bytes > 00 00 = phase 0° Parameter 00 01 = phase 90° Parameter

Manufacturer's Request Commands

Function	Code			Parameter
	EBU MEC	Manufacturer MEL	MEC1 MEC2	
Request protocol type	2D	03	FF 40	1 st byte: Interface number 00 = DTE 01 to 04 = DTE1 to DTE4 05 = DTE5 (with DMC01 only) <u>Return:</u> see EBU manufacturer's status command FD 00
Request serial number (production order number)	2D	02	FF 41	<u>Return:</u> see EBU manufacturer's test command F0 0A
Request Ident number (Stock number)	2D	02	FF 42	<u>Return:</u> see EBU manufacturer's test command F0 0B
Request coder type	2D	02	FF 43	<u>Return:</u> see EBU manufacturer's test command F0 0C
Request firmware version	2D	02	FF 44	<u>Return:</u> see EBU manufacturer's status command FD 01
Request physical address (manufacturer address)	2D	02	FF 45	<u>Return:</u> see EBU manufacturer's test command F0 05
Request Battery check	2D	02	FF 46	<u>Return:</u> see EBU manufacturer's test command FD 02

Manufacturer's Status Commands

Function	Command			Return
	EBU MEC	Manufacturer MEL	MEC1 MEC2	
Status Protocol type	2D	04	FD 00	1 st byte: Type of protocol 45 = EBU, 4C = Link, 54 = TNPP 2 nd byte: RBDS 52 = on, 00 = off
Status Firmware version	2D	12	FD 01	< 16 Byte >
Status Battery check	2D	04	FD 02	< 2 Byte > 00 00 = defective 00 01 = o.k.

Manufacturer's Test Commands

*) These commands are for service only, not for user.

Function	Command			Parameter
	EBU MEC	Manufacturer ML1	MLC1 MLC2	
Set test command enabled only for one test set command or test request command	2D	04	F0 00	1st and 2nd byte: Parameter 00 01 = set for one test command 00 00 = test mode canceled
Request parallel remote control inputs E1 to E16 (REMOTE CONTROL / X11)	2D	02	F0 03	00 00 Parameter <u>Return:</u> see EBU Manufacturer's command F0 04
Status parallel remote control inputs E1 to E16 (REMOTE CONTROL / X11)	2D	04	F0 04	<2 bytes> Value
Set physical address (manufacturer's address)	2D	04	F0 05	<2 bytes> Address
Set start update Flash memory (Update firmware)	2D	04	F0 06	1st and 2nd byte: Parameter 00 01 start flash pro
Set Cold start	2D	04	F0 07	1st and 2nd byte: Parameter 00 01 Cold start
Set Warm start	2D	04	F0 08	1st and 2nd byte: Parameter 00 01 Warm start
Set Serial number *) (production order number)	2D	12	F0 0A	<16 bytes> Information
Set Ident number *) (Stock number)	2D	12	F0 0B	<16 bytes> Information
Set Type of coder *)	2D	12	F0 0C	<16 bytes> Information
Set Watchdog on/off	2D	04	F0 0D	1st and 2nd byte: Parameter 00 00 = off 00 01 = on

Draft SPB 490

*Universal encoder
communication protocol*

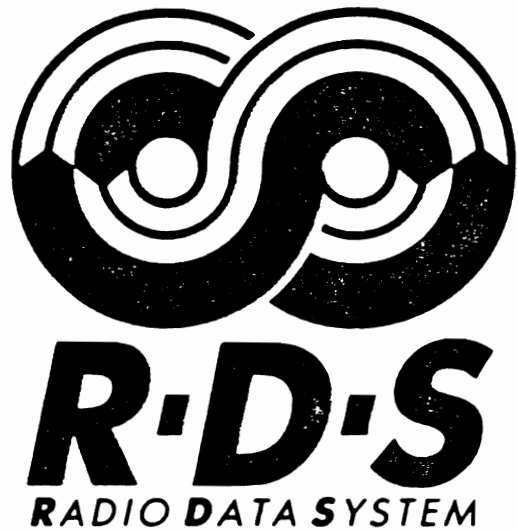

european broadcasting union

Geneva

November 1992

2048.1868.00 - 1 E-1

FOREWORD

The EBU has a requirement that the various RDS encoder communication protocols should be harmonized. Such harmonization would enable broadcasters to purchase RDS system components (encoders, update generators etc.) from a variety of sources. RDS component manufacturers would then be able to integrate their products with those from other manufacturers, enabling more complex systems to be produced than otherwise possible.

Most protocols have similar functional elements. However, they differ significantly in their environmental models. The structure, functionality, and addressing of their intended networks, and the data structures within each encoder are often quite different. Therefore this specification is based on harmonized environmental and encoder models.

This document describes these harmonized models and a universal layered protocol, based on the ISO/OSI recommendation, which encompasses all current RDS features, and can also accommodate new developments.

Encoders based on this model may not currently exist, but the model and protocol provide a template specification upon which new products may be based. Many existing devices could be adapted to meet the functionality required, and subsequently the universal protocol may be implemented. An encoder does not need to implement all the features described, but any feature implemented must be made in accordance with this standard.

The EBU thanks the following organizations and manufacturers for having contributed to the elaboration of this specification: TDF, BBC, Teli, Teleray, Rohde & Schwarz, RE Technology, Velec and VG Electronics.

CONTENTS

1.	Environmental model	4
1.1	Addressing method	4
1.2	Encoder model	6
1.3	Transmission modes	8
2.	Protocol description	9
2.1	Physical layer	9
2.2	Data Link Layer	11
2.3	Message field format	14
2.4	Message codes	15
2.5	Description of data handling	16
3.	Message description	18
3.1	List of all defined commands	18
3.2	Command repertoire	19
	Appendix 1: CCITT Polynomial	67
	Appendix 2: Glossary	69

1. Environmental model

1.1 Addressing method

Communication to RDS encoders needs to be capable of many levels of addressing: to all encoders, to specific sets of encoders or to a particular device. This may be accomplished by unique physical connections or by a suitable logical addressing method.

In defining an environmental model for the universal protocol, the following assumptions are made:

- The data stream will feed one or more transmitter sites. Each site will have a unique address, known as the site address (a number in the range 1-1023). All encoders at a particular transmitter site share the same site address.
- An encoder will possess one or more site addresses. One of these must be unique to the particular physical site location. Additional site addresses are permitted for a particular area, region, or country.

To clarify this concept, an example is given. All encoders at the NEWTOWN site have the unique site address "123". Other encoders in the system are not permitted to use this address. Encoders at the NEWTOWN site also have the site address "267", which is allocated to all encoders in the LAKEVALLEY area. Messages arriving at the NEWTOWN site with either of these two site addresses will be accepted. Messages arriving at the LITTLEVILLAGE site (address "452"), also in the LAKEVALLEY area, will not be accepted if they carry the NEWTOWN site address, but will be accepted if they carry either the LITTLEVILLAGE or the LAKEVALLEY site address.

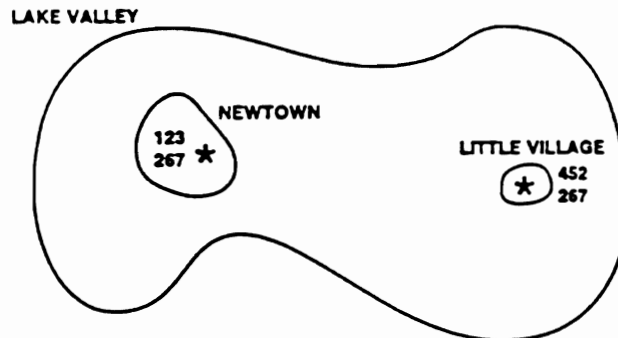

Fig. 1: Fictitious example of site addressing

Several RDS encoders are installed at each transmitter site, serving a number of programme services. Backup equipment is sometimes provided, sometimes not. A single backup encoder may even be provided for several programme services. Whatever the situation may be, each encoder at the site needs to be individually addressable. A second level of addressing is therefore introduced, the encoder address (a number in a range 1-63).

An encoder will possess one or more encoder addresses. One must be unique to the encoder at that site. Additional encoder addresses may be assigned according to the encoder's usage or manufacture. However, the site and encoder addresses are not intended to specify a particular radio service. The specification of a particular radio service, a third level of addressing, is accomplished by using a programme service number, defined in section 1.2.1. The site and encoder addresses should be thought of as being entirely physical, and are used only to address a certain "box" at a certain location, the functionality of the "box" is irrelevant in this context.

It is expected that many messages will be sent to all encoders. Thus, the global number of "0" is defined for both the site and encoder addresses. Messages bearing the global site address are deemed to be acceptable at all sites in the system. Messages bearing the global encoder address are deemed to be acceptable at all encoders at sites specified by the accompanying site address.

An encoder will have two address lists, one of acceptable site addresses and the other of acceptable encoder addresses. The site address list includes "0" (the global site address), the unique site address and any additional site group addresses. The encoder address list includes "0" (the global encoder address), the unique encoder address and any additional encoder group addresses.

A message is acceptable to a particular encoder only if the site address is contained within its site address list and the encoder address is contained within its encoder address list.

1.2 Encoder model

1.2.1 Software model

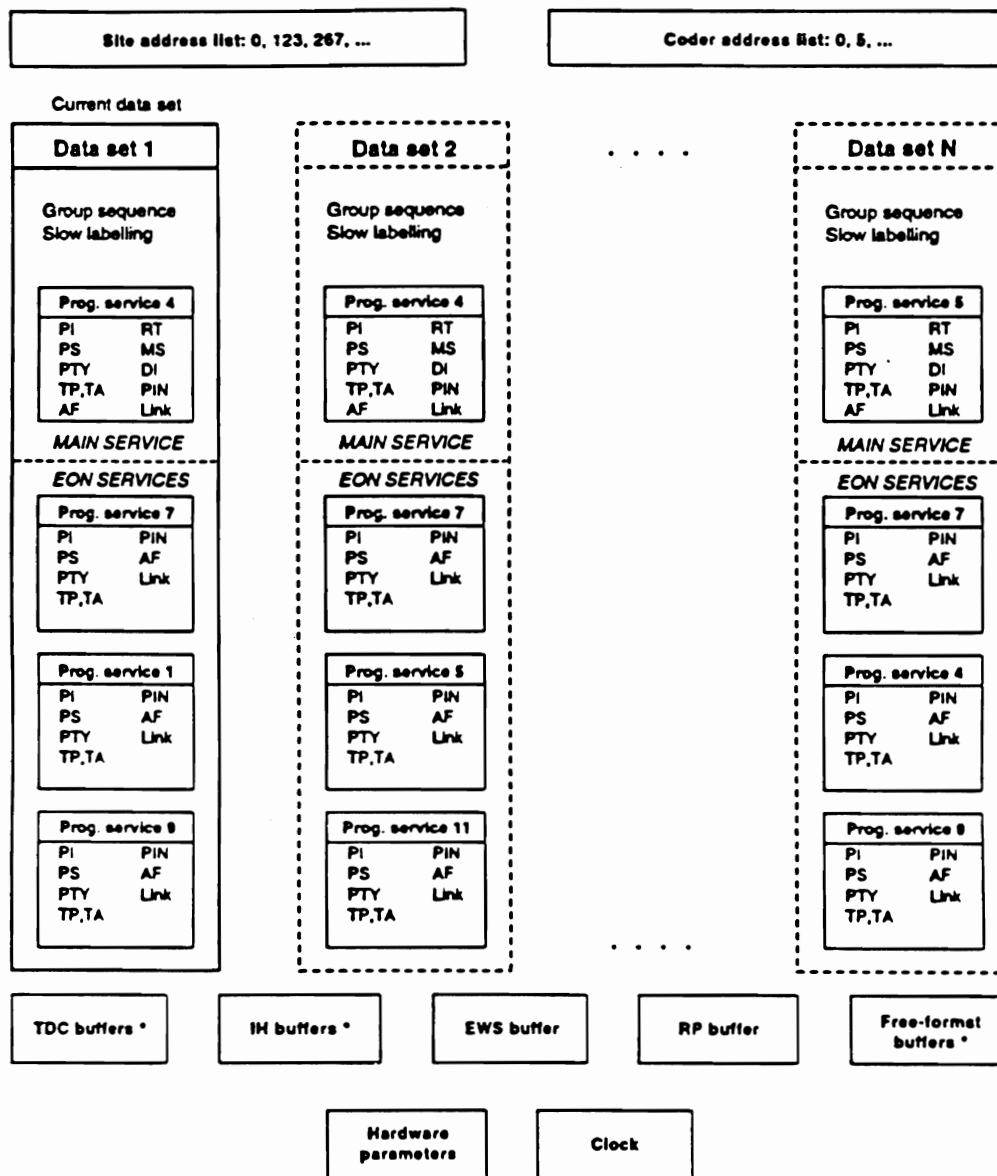

* Separate buffers for A and B type groups should be used

Fig. 2: RDS Encoder Software Model

Messages are accepted by the encoder in accordance with the addressing method described in section 1.1. Applicability is further determined by optional fields within the message itself. This permits addressing of the following structures within an encoder:

Data sets: An encoder will have one or more data sets, each of which results in a particular RDS output. Each data set may refer to many programme services using the RDS EON feature. Only one data set is responsible at any one time for the encoder's output, and

is known as the current data set. Data sets are addressed by the protocol as described in section 2.3.2.

Programme services: All programme services are identified by a unique programme service number which is used to label data within RDS networks. In a network providing the EON feature, data for several programme services will be sent to an encoder which may then identify that the data refers to one or more of the data sets and elements within the data sets used by that encoder. Programme services are addressed by the protocol as described in section 2.3.3.

1.2.2 Hardware model

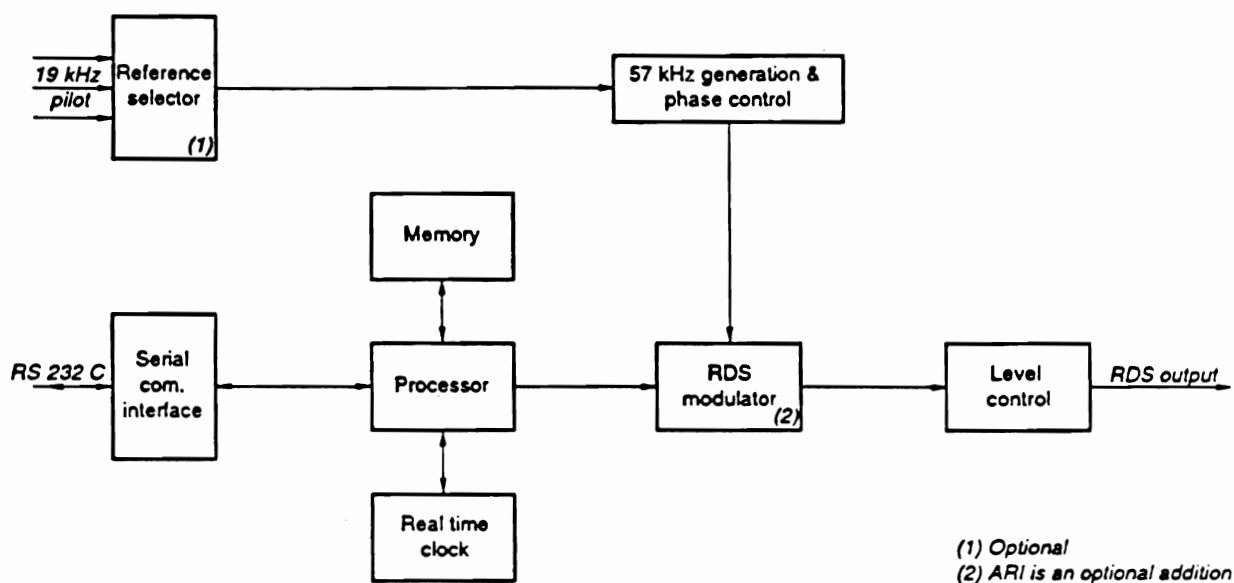

Fig. 3: RDS Encoder Hardware Model

A simplified model of an RDS encoder has been used in the development of this universal protocol and is shown in Figure 3. The model does not include such obvious or necessary components as a power supplier or control panel, but includes only the blocks necessary to understand and develop the protocol itself. These are:

Processor: The central processing unit of the encoder, usually a micro-processor, with access to input and output devices, the real-time clock, and memory.

Memory: Comprises ROM and RAM necessary for the operating software of the encoder, and appropriate RAM, NVRAM, and ROM for stored data.

Real time clock: Maintains the current time of day and calendar date. Used to generate type 4A groups (CT).

Serial communication interface: Data, according to this protocol, is received and transmitted using the serial communications interface.

RDS modulator: Produces the RDS bi-phase signal, and optionally ARI in accordance with CENELEC EN 50067.

57 kHz oscillator: Frequency and phase locked to the third harmonic of the selected reference source.

Reference selector (optional): Selects one source of 19 kHz reference signal, out of a maximum of six, to lock to the internal 57 kHz oscillator. Each 19 kHz reference source corresponds to a specific level and phase adjustment of the produced output signal. When a specific reference source is selected via the Reference selector, the corresponding level and phase values are taken from a "reference entry table". This table comprises the following parameters:

- RDS output level
- RDS phase
- ARI level (if implemented)

Level and phase control: The level and phase of the RDS signal (optionally ARI) may be adjusted by the processor under the appropriate commands (see pp. 45 and 46). The Output level may be set in the range 0 to 8191 mV, and the phase in the range between 0 and 180 degrees to lock to the internal 57 kHz oscillator. Level and phase of the RDS signal may depend of the 19 kHz reference signal. As up to six reference inputs may be used, level and phase are set on the "reference table entry", as mentioned under Reference selector.

1.3 Transmission modes

The universal protocol is designed to operate in various communication modes as follows:

1.3.1 Uni-directional mode

This mode is used on one way communication links. Data is transmitted to one, a group or all encoders. Answer back is not required.

1.3.2 Bi-directional mode, requested response

This mode uses a two-way communication link to transmit data to one, a group or all encoders. It enables the server to request data, status, and error report from encoders.

1.3.3 Bi-directional mode, spontaneous response

A two-way communication link enables a server to transmit data to encoders, and request data from encoders. Encoders are also able to spontaneously generate status and error messages. Such messages, their content and application are described in section 3.

2. Protocol description

2.1 Physical layer

Specification at this level is necessary to ensure electrical and mechanical compatibility of equipment. Interfacing to the encoder is accomplished with a serial interface based on the well-known standard EIA RS 232C (compatible with V24/V28). This is a full-duplex interface with hardware handshaking, able to operate with modems.

2.1.1 Mechanical specification

The encoder should be equipped with either the 25-pin SUB-D or the 9-pin SUB-D connectors. The 9-pin SUB-D connector would be preferred. Converting between the two types of connectors is easily done via commonly available adapters. The interface is designed as a DTE (Data Terminating Equipment) and therefore the connectors should be of a male type.

Signals on the 9-pin connector for DTE (IBM-compatible) are given in Table 1.

Table 1

<i>Pin</i>	<i>Signal</i>	<i>I/O</i>	<i>Signal description</i>
1	DCD	I	Data Carrier Detect (optional)
2	RxD	I	Received Data
3	TxD	O	Transmitted Data
4	DTR	O	Data Terminal Ready
5	GND	-	Signal Ground
6	DSR	I	Data Set Ready
7	RTS	O	Request to Send
8	CTS	I	Clear to Send
9	RI/+5...+15V	I/O	Ring Indicator (optional) or auxiliary supply voltage (optional)

Signals on the 25 pin connector for DTE are given in Table 2.

Table 2

<i>Pin</i>	<i>Signal</i>	<i>I/O</i>	<i>Signal description</i>
1	PE	-	Protection Earth
2	TxD	O	Transmitted Data
3	RxD	I	Received Data
4	RTS	O	Request to Send
5	CTS	I	Clear to Send
6	DSR	I	Data Set Ready
7	GND	-	Signal Ground
8	DCD	I	Data Carrier Detect (optional)
18	+5...+15V	O	Auxiliary Supply Voltage
20	DTR	O	Data Terminal Ready

2.1.2 Signal description

The specified interface is an electrical unbalanced circuit with signal levels according the EIA RS 232C.

The signals have the following functionality:

PE (Protection Earth):	Is available only on the 25-pin connector and should be tied to the encoder case internally
TxD (Transmitted Data):	Data from the encoder to an external device
RxD (Received Data):	Data from an external device to the encoder
RTS (Request to Send):	The OFF-State on this line is used to indicate to an external device to pause with data transmission on RxD until RTS is switched to the ON-State again (also called dynamic handshake)
CTS (Clear to Send):	The OFF-State on this line is used to indicate to the encoder to pause with data transmission on TxD until CTS is switched to the ON-State again (also called dynamic handshake)
DSR (Data Set Ready):	The ON-State on this line is used to indicate to the encoder that an external device is connected and is ready for operation (also called static handshake)
DTR (Data Terminal Ready):	The ON-State on this line is used to indicate to an external device that the encoder is ready for operation (also called static handshake)
GND (Signal Ground):	Analog Ground for the circuitry (not shield)
DCD (Data Carrier Detect):	This signal can be (optional) evaluated to detect an active modem
RI (Ring Indicator):	This optional signal can be evaluated to detect an incoming call from modem.
+5..+15V:	This (optional) signal is an auxiliary supply voltage for external low power devices, such as level converters or fiber optic devices, and should be current limited.

Remarks:

- If DTR/DSR signals are OFF, the corresponding RTS/CTS signals must also be in OFF-state.
- If hardware handshake is used, then it should work in this way. If it is not used, the system should be operated at a suitable data rates which guarantees that no characters are dropped.

2.1.3 Data format

The data is transmitted character by character in asynchronous mode.

Characters of 8 bits are transferred, preceded by 1 start bit and followed by 1 stop bit. No parity bit is included. Transmission speeds will be the following standard values 75, 150, 300, 600, 1200, 2400, 4800, 9600 and 19200 bps.

2.2 Data Link Layer

Update data comprises a stream of data frames. A frame comprises a series of bytes, delimited by two reserved bytes, which mark the beginning and end of the frame. Each frame contains a destination address, defining the set of encoders to which the record is being sent. A sequence counter labels each separate record. The message itself is preceded by a byte defining the message length, and followed by a CRC check.

The start and stop bytes are uniquely defined, and may not occur in any other fields of a frame. In order to prevent this, a frame is byte-stuffed prior to transmission. Byte-stuffing transforms an illegal occurrence of a reserved byte into two legal bytes. The reverse process is applied at reception, byte-stuffed frames are converted prior to frame processing. Thus, although the start and stop bytes are reserved, messages may freely use bytes with any value. In cases where reserved byte values are present in the message, the transmitted message length will be increased. However, the length of a message is always defined in its unstuffed, shortest, state.

2.2.1 General Frame Format

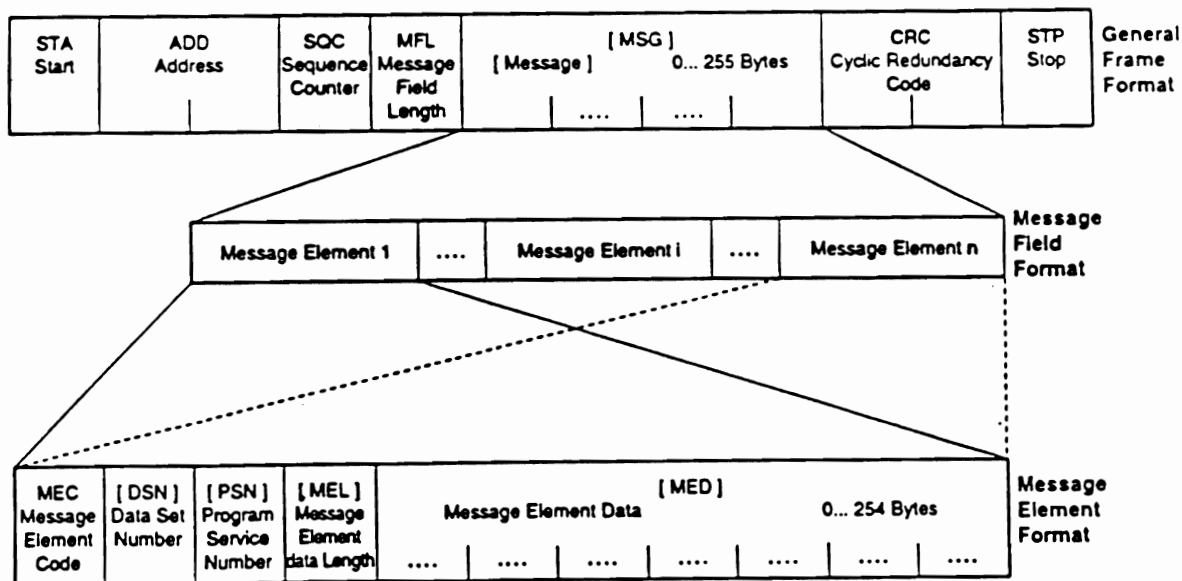

[] Fields in brackets are optional. Inclusion is inherently defined by the Message Element Code

Fig. 4: Data protocol format

Each data frame has the following format:

<u>Field Description</u>	<u>Descriptor</u>	<u>Field Length</u>
Start	STA	1 byte
Address	ADD	2 bytes
Sequence Counter	SQC	1 byte
Message field length	MFL	1 byte
[Message]*	[MSG]	0...255 bytes
Cyclic Redundancy Check	CRC	2 bytes
Stop	STP	1 byte

Frames are built according to this structure, and then byte-stuffed prior to transmission. Byte-stuffing removes any occurrences of reserved bytes (FE and FF) within the fields "Address" to "Cyclic Redundancy Check" inclusively.

The complete frame is represented in Figure 4.

2.2.2 Start (STA)

A data record starts with the start byte (FE hex). This byte will not occur at any other point in a transmitted sequence (after byte-stuffing).

2.2.3 Address (ADD)

The address field comprises two elements, these are:

Site address	10 bits (most significant)
Encoder address	6 bits (least significant)

For a message to be acceptable to a particular encoder, the site address must be contained within its site address list and the encoder address must be contained within its encoder address list.

2.2.3.1 Site address

The site address defines the site, or group of sites to which this record is being sent.

0	=	All sites
1-3FF hex	=	Specific site or group of sites, as selected by encoder operator.

Each encoder will acknowledge a series of site address codes. One must be unique, i.e. common to all encoders at a particular location. Another may be common to all encoders in a certain area, and so on.

* [] This field is optional. When not included the message field length will be set to zero. Such a record may be used to indicate an idle line.

2.2.3.2 Encoder address

The encoder address defines to which encoder(s) at a particular site this record is being sent.

0 = All encoders at the site

1-3F hex = Specific encoder or group of encoders, as selected by the encoder operator.

Each encoder will acknowledge one or more encoder address codes. One must be unique (i.e. at that site), another may be common to all encoders providing a certain RDS facility, and so on.

2.2.4 Sequence Counter (SQC)

Each frame transmitted may be assigned a sequential number in the range 01-FF hex. Repetitions of any given frame, transmitted to increase data reliability in a simplex system or by request in a duplex system, can be assigned the original sequence number. Such repetitions must be completed before the current sequence counter, i.e. that used for new frames, is 100 decimal steps in advance, in order to avoid confusion between a repeat and a new record from a subsequent sequence. In the duplex mode the absence of a number in a received sequence may be used to request repetition of the particular record. If the sequence counter is not used, this field should be set to 00 hex.

2.2.5 Message field length (MFL)

This single byte informs the encoder of the number of bytes in the message field. This length is defined as that prior to byte-stuffing.

2.2.6 Message (MSG)

The message comprises 0 to 255 bytes of data. These bytes may freely take any value in the range 00-FF hex. Byte stuffing is applied afterwards (see 3.2.9.). The message field format is defined in section 2.3.

2.2.7 Cyclic Redundancy Check (CRC)

The check field consists of two bytes (prior to byte-stuffing) which represent the result of a 16-bit cyclic redundancy check (CRC) calculation.

The divisor polynomial used to generate the CRC is the CCITT polynomial, $x^{16} + x^{12} + x^5 + 1$. The CRC calculation starts with the most significant bit of the first byte of the address field, and ends with the least significant bit of the last byte of the message field. The CRC is initialized to a value of FFFF (hex), and the two check bytes are formed from the inverse of the result. The eight most significant bits are represented by the first check field byte, and the eight least significant bits are represented by the second check field byte (see also Appendix 1).

2.2.8 Stop (STP)

A data record ends with the stop byte (FF hex). This byte will not occur at any other point in a transmitted sequence (after byte-stuffing).

2.2.9 Byte-stuffing method

The technique of byte-stuffing allows a byte oriented protocol such as this to preserve certain unique values for framing purposes, and yet allow conveyed messages to utilize the full byte range (00-FF hex). This is achieved by trapping reserved bytes in illegal fields, and transforming them into legal byte pairs.

Byte values FD hex, FE hex, and FF hex are trapped in the fields "Address" to "Cyclic Redundancy Check" and transformed into a pair of bytes as shown in Table 3.

Table 3

<i>Byte</i>		<i>Resultant byte pair</i>
FD	transformed into	FD 00
FE	transformed into	FD 01
FF	transformed into	FD 02

Thus, the reserved bytes (FE and FF) will never occur within these fields in a transmitted record, and will only occur within the start and stop fields.

When a message is received, the reverse technique is used to transform two-byte sequences (always starting with FD hex), into single bytes prior to the record being processed.

2.3 Message field format

2.3.1 Message structure

The message field, if non-zero in length, consists of one or more message elements. Each message element has the structure as shown in Table 4.

Table 4

<i>Field description</i>	<i>Descriptor</i>	<i>Field length</i>
Message Element Code	MEC	1 byte
[Data Set Number]*	[DSN]*	0...1 byte
[Programme Service Number]*	[PSN]*	0...1 byte
[Message element data length]*	[MEL]*	0...1 byte
[Message element data]*	[MED]*	0...254 bytes

Several message elements may be packed together into one message field, subject to a maximum message field length of 255 bytes, as defined in section 2.2.1. An individual message element must not be split between different message fields.

The complete message field may be represented as follows:

MEC,[DSN],[PSN],[MEL],[MED],[[MEC,[DSN],[PSN],[MEL],[MED]]], ...

Fields and whole message elements shown in square brackets are optional. Message elements may be concatenated freely, subject to a maximum message field length of 255 bytes.

* [] These fields are optional. They are used, as required by the specific command. See section 3.

The maximum available length for a message element is 255 bytes. This inherently limits the message data to 254 bytes. If the optional fields "Data Set Number", "Programme Service Number", and/or "Message element data length" are utilized, further reduction to the maximum data length will occur. For example, if all optional fields are employed, the maximum data length will be 251 bytes.

2.3.2 Data Set Number (DSN)

The Data Set Number (DSN) permits a message to be targeted to the following within an encoder:

- a specific data set,
- the current data set,
- all data sets.

The DSN within a message element is chosen as shown in Table 5.

Table 5

<i>Data Set Number (DSN)</i>	<i>Target</i>
0	Current data set
1-253	Specific data set
254	All data sets except the current data set
255	All data sets

2.3.3 Programme Service Number (PSN)

The Programme Service Number (PSN) permits a message element to operate a number of services within one or more data sets and the corresponding addressing is shown in Table 6.

Table 6

<i>Programme Service Number (PSN)</i>	<i>Target</i>
0	Special PSN for main service of specified data set(s)
1-255	Specific service within data set(s)

2.4 Message codes

Message codes are described in section 3. Different classes of message are thus identified.

2.4.1 Remote and configuration commands

These commands allows to control the various functionality of encoders or permit to request messages from the encoders in a case of bi-directional transmission mode.

2.4.2 RDS messages

These messages are related to all the RDS features which have to be processed by an encoder.

2.4.3 Status messages

These messages are used in bi-directional transmission mode to transmit information from an encoder to another device.

2.4.4 Specific messages

These types of messages are not allocated in this specification and concern specific and internal functionality which can be needed by encoder manufacturers. Specific code are reserved for these types of message and should not be used for other features.

2.5 Description of data handling

The data is transmitted to the encoder using the specified commands described in section 3, and stored in memory according to the encoder software model (see section 1.2.1).

2.5.1 Group sequence

The encoder must be told about the types of groups are to be transmitted and about the appropriate transmission rate for every transmitted group type.

This is achieved with the "Group sequence" command, which is treated by the encoder like a group enable command. When a specific group is encountered in the sequence, data relating to that type is transmitted if available. If not then the group type is not generated and the next group type in the sequence is used instead.

If the group sequence contains a 7A group , then the encoder is in the paging mode.

With this method also the desired repetition rate for every group type is implicitly defined in a very flexible way for the broadcaster.

However, there are special transmission conditions to which is paid attention with the following rules:

2.5.1.1 Insertion of Group type 4A (CT)

Group type 4A is not allowed in the group sequence. If the CT function is set to ON-State (see CT-ON/OFF command) group type 4A is inserted automatically by the encoder at the edge of the minute.

During inserting group 4A the given group sequence is suspended for this one group. This action has highest priority against any other event (e.g. inserting group type 14B due to change of TA flag).

If the CT function is set to the OFF-State, no group 4A is inserted at any time.

2.5.1.2 Handling of Group type 1A

There are two possibilities:

If the encoder is in the non-paging mode, the group 1A is processed as given in the group sequence and is treated like any other group type.

If the encoder is in the paging mode, the group 1A is transmitted every second and is also marking every paging interval. This is done by the encoder automatically when in paging mode. In order not to influence this structure the given group types 1A in the group enable sequence are ignored.

In the paging mode the transmission of group 1A every second (in conjunction with group 4A at the edge of the minute) has highest priority against other events.

When inserting groups 1A or 4A the given group sequence (given 1A groups ignored!) is suspended for one group.

2.5.1.3 Insertion of group 14B

Group type 14B is not allowed in the group sequence. In order to turn "on" the TA flag for EON services, group 14B is inserted eight times automatically by the encoder, interrupting the given group sequence as a consequence.

If the encoder is in a paging mode, groups 4A and 1A, for marking the intervals, have the highest priority. In the worst case, the inserted 14B groups are delayed.

2.5.1.4 Insertion of group 15B

Similar to the insertion of 14B groups, group type 15B is inserted (8 times) automatically by the encoder when the TA flag for the main service changes.

If the encoder is in a paging mode, 4A and 1A groups for marking the intervals have the highest priority. In the worst case, the inserted 15B groups are delayed.

3. Message description

3.1 List of all defined commands

<u>RDS message commands</u>	<u>Message Element Code</u>	<u>Page</u>
PI	01	20
PS	02	21
PIN	06	22
DI	04	23
TA/TP	03	24
MS	05	25
PTY	07	26
RT	0A	27
AF	13	28
EON AF	14	29
Slow Labelling codes	1A	30
Linkage information	2E	31
<u>Transparent data commands</u>		
TDC	26	32
EWS	2B	33
IH	25	34
Free-format group	24	35
<u>Paging commands</u>		
Paging call without message	0C	36
Paging call with numeric message (10 digits)	08	37
Paging call with numeric message (18 digits)	20	38
Paging call with alphanumeric message (80 characters)	1B	39
International paging with numeric message (15 digits)	11	40
International paging with functions message	10	41
Paging network group designation	12	42
<u>Clock setting and control</u>		
Real time clock	0D	43
Real time clock correction	09	44
CT on/off	19	45
<u>RDS adjustment and control</u>		
RDS on/off	1E	46
RDS phase	22	47
RDS level	0E	48
<u>ARI adjustment and control</u>		
ARI on/off	21	49
ARI area (BK)	0F	50
ARI level	1F	51

<u>Control and set up commands</u>	<u>Message Element code</u>	<u>Page</u>
Site address	23	52
Encoder address	27	53
Make PSN list	28	54
PSN enable/disable	0B	55
Communication mode	2C	56
TA control	2A	57
EON TA control	15	58
Reference input select	1D	59
Data set select	1C	60
Group sequence	16	61
Group usage code sequence	29	62
PS character code table selection	2F	63
<u>Bi-directional commands (Remote and configuration commands)</u>		
Message acknowledgement	18	64
Request message	17	65
<u>Specific message command</u>		
Manufacturer's specific command	2D	66

3.2 Command repertoire (see pp. 20 to 66)

First Column	Second Column	Third Column
--------------	---------------	--------------

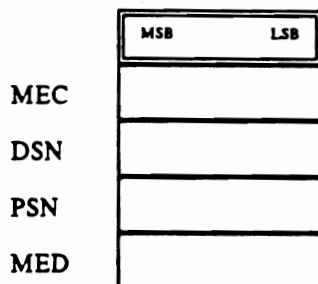

Conventions:

The message description is made according to the above diagram. The first column indicates the descriptor of the message which is detailed in the table (2nd column).

Each element in the table represents one byte where the bits are numbered from 7..0 (from left to right). For transmission of a respective message each byte is represented by two HEX symbols of which the permitted range is indicated in the respective element. The message structure used is explained in section 2.3.1. Symbol 00..XX or 0..X, 0..X specifies the range of the HEX value that may be used.

The third column gives an information of the context of the table. Symbol HEX means that any HEX value may be used. Any other information describes the nature of the data which is put in the table.

The coding of all RDS features is in the same format as used in CENELEC EN 50067, unless otherwise specified.

Message Name: PI

Message Element Code: 01

Function: To set the PI code of the specified Programme Service(s) of the specified Data Set(s)

Format:

	MSB	LSB	
MEC	01		
DSN	00..FF		
PSN	00..FF		
MED	00..FF		PI (MSB)
MED	00..FF		PI (LSB)

Example: <01> <00> <01> <C2> <01>

Set PI code in current data set for programme service 1 to C201.

Message Name: PS

Message Element Code: 02

Function: To set the PS name of the specified Programme Service(s) of the specified Data Set(s)

Format:

	MSB	LSB	
MEC	02		
DSN	00..FF		
PSN	00..FF		
MED	20..FF		PS Character 1
MED	20..FF		PS Character 2
MED	20..FF		PS Character 3
MED	20..FF		PS Character 4
MED	20..FF		PS Character 5
MED	20..FF		PS Character 6
MED	20..FF		PS Character 7
MED	20..FF		PS Character 8

Example: <02> <00> <02> <52> <41> <44> <49> <4F> <20> <31> <20>

Set PS in current data set for programme service 2 to RADIO_1_.

Message Name: PIN

Message Element Code: 06

Function: To set the PIN Code of the specified programme service on the specified data set(s)

Format:

	MSB	LSB	
MEC	06		
DSN	00..FF		
PSN	00..FF		
MED	00..FD		PIN (MSB)
MED	00..FB		PIN (LSB)

Example: <06> <00> <06> <71> <5E>

Set PIN for day = 14, hour = 5, minute = 30 in current data set, programme service 6.

Message Name: DI

Message Element Code: 04

Function: To set the Decoder Information bits of the specified programme service(s) on the specified data set(s)

Format:

	MSB	LSB
MEC	-	04
DSN	00..FF	
PSN	00..FF	
MED	00..FF	DI

Example: <04> <00> <03> <01>

Set DI to stereophonic transmission (=1) in current data set, programme service 3.

Message Name: TA/TP

Message Element Code: 03

Function: To set the Traffic Announcement and Traffic Programme bits

Format:

	MSB	LSB
MEC	03	
DSN	00..FF	
PSN	00..FF	
MED	00..03	

Bit 0: TA
Bit 1: TP

Example: <03> <00> <05> <02>

Set on current data set TP = 1 and TA = 0, for programme service 5.

Message Name: MS

Message Element Code: 05

Function: To set the MS flag of the specified programme service on the specified data set(s)

Format:

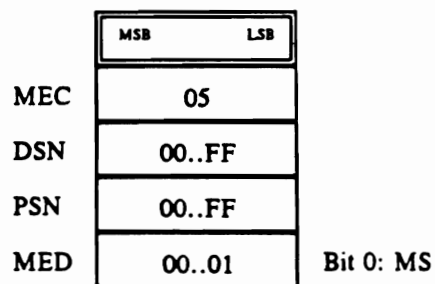

Example: <05> <00> <01> <01>

Set MS to 1 on current data set, for programme service 1.

Message Name: PTY

Message Element Code: 07

Function: To set the Programme Type information of the specified programme service on the specified data set(s)

Format:

	MSB	LSB
MEC	07	
DSN	00..FF	
PSN	00..FF	
MED	00..1F	

PTY

Conventions: Coding of PTY is according to CENELEC EN 50067.

Example: <07> <00> <05> <08>

Set PTY to 8 in current data set, programme service 5.

Message Name: RT

Message Element Code: 0A

Function: To edit Radiotext.

Format:

	MSB	LSB	
MEC	0A		
DSN	00..FF		
PSN	00..FF		
MEL	00..40		
MED	00..01		00 keep A/B flag 01 toggle A/B flag
MED	00..FF		Text character 1
MED	00..FF		Text character 2
	:		
	:		
MED	00..FF		Last Text Character (Maximum 64)

Conventions: If the PSN is not the main PSN the command is ignored.
If the text length is less than 64 characters, the rest of the buffer is flushed.
The Radiotext should be repeated in the on-air transmission, until replaced by a new Radiotext. Repetition should be stopped when a message with text-length 0 is received by the encoder.

Example: <0A> <00> <01> <04> <01> <52> <44> <53>

Send to current data set, programme service 1, message length 4, toggle A/B flag, the text "RDS".

Message Name: AF

Message Element Code: 13

Function: To edit AF data in the specified data set(s) of the specified programme service(s)

Format:

	MSB	LSB	
MEC	13		
DSN	00..FF		
PSN	00..FF		
MEL	03..FF		
MED	00..FF		Start Location (High)
MED	00..FF		Start Location (Low)
MED	01..FF		AF Data
MED	01..FF		AF Data
	:		
	:		
MED	01..FF		AF Data
MED	00		AF List terminator

Conventions: AF data are prepared for direct coding in type 0A groups. They are paired where Method B is used. An AF value of 00 terminates the AF list(s). No distinction is made between the different Methods A or B.

The start location defines the offset (in bytes) from the beginning of the AF memory used for the respective programme service, at which the new data is to be stored.

Example: <13> <00> <01> <07> <00> <00> <E2> <15> <27> <CD> <00>

AFs for current data set, programme service 1, offset by 0 bytes, are set to frequency codes E2 15 27 CD (89.6, 91.4, filler).

Message Name: EON AF

Message Element Code: 14

Function: To edit AF data on the specified EON data set(s) of the specified programme service(s)

Format:

	MSB	LSB	
MEC	14		
DSN	00..FF		
PSN	00..FF		
MEL	05..FF		
MED	00..FF		Start Location (High)
MED	00..FF		Start Location (Low)
MED	04..09		AF Data (Usage code of Group Type 14A)
MED	01..CD		AF Data
MED	01..CD		AF Data
	:		
	:		
MED	00		AF List terminator

Conventions: AF data are prepared in three byte units for direct coding in type 14A groups. The first byte of each three designates the usage code in the range 4..9. An AF value of 00 terminates the AF list(s). The start location defines the offset (in bytes) from the beginning of the AF memory used for the respective programme service, at which the new data is to be stored.

Example: <14> <00> <01> <09> <00> <00> <05> <15> <19>
<05> <18> <10> <00>

In the current data set, programme service number 1, AF memory location offset 0, set two mapped frequencies with usage code 5, main frequency 89.6 MHz, mapped frequency 90.0 MHz, usage code 5, main frequency 89.9 MHz, mapped frequency 89.1 MHz.

Message Name: Slow labelling codes

Message Element Code: 1A

Function: To edit data for group type 1A, block 3.

Format:

	MSB	LSB	
MEC	1A		
DSN	00..FF		
MED	0..7	0..F	Bits 7..4: Usage code Bits 3..0: Data MSB
MED	00..FF		Data LSB

Conventions: For each Usage code 0..7, data can be set in the range 000..FFF.

Example: <1A> <04> <00> <E2>

In data set number 4, set the data sent with usage code 0 to "0E2".

Message Name: Linkage information

Message Element Code: 2E

Function: To edit Linkage information, variant 12 of block 3 of type 14A groups. The linkage activator is also in group type 1A, block 3.

Format:

	MSB	LSB	
MEC	2E		
DSN	00..FF		
PSN	00..FF		
MED	00..FF		Link information MSB
MED	00..FF		Link information LSB

Conventions: The Linkage information is applied in 14A groups.

If the PSN specified is the main PSN, the most significant bit, the Linkage Actuator is sent in 1A groups, block 3, as well.

Example: <2E> <02> <03> <81> <23>

Set Linkage information in data set 2, programme service 3, to 8123 Hex. The Linkage Actuator is set to 1. If programme service 3 is the main PSN, the Linkage Actuator will be transmitted in group 1A as well with value 1.

Message Name: TDC

Message Element Code: 26

Function: To edit the data for the Transparent Data Channel

Format:

	MSB	LSB	
MEC	26		
MEL	00..FF		
MED	00..01		00 = Group Version A 01 = Group Version B
MED	00..1F		Channel
MED	00..FF		Data
MED	00..FF		Data
	:		
	:		
MED	00..FF		Data

Conventions: The data in the command are sent together with the given binary coded channel number. This information is transmitted only once.

In the case of B type groups, the information for block 3 will be overridden by the information of the PI code.

The first byte of the first Message Element Data indicates the TDC channel number as follows:

Bits 0 to 4 = channel number (00..1F)

Bits 5 to 7: Set to 0 (reserved)

Example: <26> <04> <01> <46> <42> <55>

Send the data "EBU" as TDC channel 1.

Message Name: EWS

Message Element Code: 2B

Function: Edit the Emergency Warning System data (37 bits) in group type 9A.

Format:

	MSB	LSB	
MEC	2B		
MED	00..1F		Block 2 (5 Bits)
MED	00..FF		Block 3 MSB
MED	00..FF		Block 3 LSB
MED	00..FF		Block 4 MSB
MED	00..FF		Block 4 LSB

Conventions: 37 bits of EWS data are to be sent to the encoder's internal EWS buffer. This information is transmitted only once.

Example: <2B> <01> <23> <45> <67> <89>

Set EWS data to 01 2345 6789 for group type 9A.

Message Name: IH

Message Element Code: 25

Function: To edit the In-house applications and specify the group version

Format:

	MSB	LSB	
MEC	25		
MED	00..01		00 = Group Version A 01 = Group Version B
MED	00..1F		Block 2 (5 Bits)
MED	00..FF		Block 3 MSB
MED	00..FF		Block 3 LSB
MED	00..FF		Block 4 MSB
MED	00..FF		Block 4 LSB

Conventions: The data in 6A or 6 B groups block 2, 3, and 4 are sent as 10 hex numbers.

In the case of B type groups, the information for block 3 will be overridden by the information of the PI code.

Example: <25> <00> <01> <23> <45> <67> <89>

Set IH data to 01(block 2) 2345(block 3) 6789(block4) hex in group type 6A.

Message Name: Free-format group

Message Element Code: 24

Function: To add a group to the free-format buffer for that group type

Format:

	MSB	LSB	
MEC	24		
MED	00..1F		Bits 4..1: Group Type number Bits 0: Group Type A or B
MED	00..1F		Block 2 (5 Bits)
MED	00..FF		Block 3 (MSB)
MED	00..FF		Block 3 (LSB)
MED	00..FF		Block 4 (MSB)
MED	00..FF		Block 4 (LSB)

Conventions: Normally an encoder has activated a specific group sequence with associated data. If some free format data is put into the encoder for the active groups, the free-format data is transmitted and the "standard RDS data" is suspended until the free format data has been transmitted. If free format data is put in for a group type which is not declared for normal operation, the free-format data should not be transmitted. For transmission the necessary group for free format data has to be inserted into the group sequence in addition to the "normal RDS groups".

Example: <24> <07> <0C> <00> <00> <AB> <DE>

Data for Group Type 3B, Block 2 data is 0C hex, Block 3 data will be overwritten by PI code because Group Type B is selected, Block 4 data is AB DE hex.

Message Name: Paging call without message

Message Element Code: 0C

Function: To send a paging call with no message and specify the number of repetitions.

Format:

	MSB	LSB	
MEC	0C		
MED	0..F	0..F	Bits 7..4: Number of repetitions (max 15) Bits 3..0: Pager address (MSB)
MED	00..FF		
MED	00..FF		

Conventions: The first Hex number (bits 7..4) of the first byte of the Message Element Data (MED) is used to define the number of repetitions of a paging call. If this number equals 0, the default repetition number shall be used. The second Hex number (bits 3..0) of the first byte of the MED and the next two bytes of the MED, represent 20 bits for Hex coding of the pager address number (a number of 6 digits).

Example: <0C> <20> <25> <34>

Send a call, twice, to pager "009524" (02534 Hex).

Message Name: Paging call with numeric message (10 digits)

Message Element Code: 08

Function: To send a paging call with a 10 digit numeric message and specify the number of repetitions.

Format:

	MSB	LSB	
MEC	08		
MED	0..F	0..F	Bits 7..4: Number of repetitions (max 15) Bits 3..0: Pager address (MSB)
MED	00..FF		Bits 7..0: Pager address
MED	00..FF		Bits 7..0: Pager address (LSB)
MED	0..A	0..A	Message (first 2 digits)
MED	0..A	0..A	Message (second 2 digits)
MED	0..A	0..A	Message (third 2 digits)
MED	0..A	0..A	Message (fourth 2 digits)
MED	0..A	0..A	Message (fifth 2 digits)

Conventions: The first Hex number (bits 7..4) of the first byte of the Message Element Data (MED) is used to define the number of repetitions of a paging call. If this number equals 0, the default repetition number shall be used. The second Hex number (bits 3..0) of the first byte of the MED and the next two bytes of the MED, represent 20 bits for Hex coding of the pager address (6 digits). The remainder of the MED contains the 10 digit message, in conformity with CENELEC EN 50067.

Example: <0D> <31> <84> <86> <72> <10> <01> <1A> <AA>

Send the message "7210011___", three times, to pager "099462" (18486 Hex).

Message Name: Paging call with numeric message (18 digits)

Message Element Code: 20

Function: To send a paging call with an 18 digit numeric message and specify the number of repetitions

Format:

	MSB	LSB	
MEC	20		
MED	0..F 0..F		Bits 7..4: Number of repetitions Bits 3..0: Pager address (MSB)
MED	00..FF		Bits 7..0: Pager address
MED	00..FF		Bits 7..0: Pager address (LSB)
MED	0..A 0..A		Message (first 2 digits)
MED	0..A 0..A		Message (second 2 digits)
MED	0..A 0..A		Message (third 2 digits)
	:		
	:		
MED	0..A 0..A		Message (eighth 2 digits)
MED	0..A 0..A		Message (last 2 digits)

Conventions: The first Hex number (bits 7..4) of the first byte of the Message Element Data (MED) is used to define the number of repetitions of a paging call. If this number equals 0, the default repetition number shall be used. The second Hex number (bits 3..0) of the first byte of the MED and the next two bytes of the MED, represent 20 bits for Hex coding of the pager address (6 digits). The remainder of the MED contains the 18 digit message, in conformity with CENELEC EN 50067.

Example: <20> <F1> <84> <80> <72> <10> <01> <10> <03> <31> <83> <95> <72>

Send the message "721001100331839572", 15 times, to pager "099456" (18480 Hex).

Message Name: Paging call with alphanumeric message (80 characters)

Message Element Code: 1B

Function: To send a paging call with up to an 80 character alphanumeric message and specify the number of repetitions

Format:

	MSB	LSB	
MEC	1B		
MEL	4..53		Message element length
MED	0..F 0..F		Bits 7..4: Number of repetitions Bits 3..0: Pager address (MSB)
MED	00..FF		Bits 7..0: Pager address
MED	00..FF		Bits 7..0: Pager address (LSB)
MED	00..FF		Message (first character)
MED	00..FF		Message (second character)
MED	00..FF		Message (third character)
	:		
	:		
MED	00..FF		Message (last character) Maximum of 80 characters.

Conventions: The first Hex number (bits 7..4) of the first byte of the Message Element Data (MED) is used to define the number of repetitions of a paging call. If this number equals 0, the default repetition number shall be used. The second Hex number (bits 3..0) of the first byte of the MED and the next two bytes of the MED, represent 20 bits for Hex coding of the pager address (6 digits). The remainder of the MED contains the alphanumeric message, in conformity with CENELEC EN 50067.

Example: <0F> <08> <41> <E2> <40> <48> <65> <6C> <6C> <6F>

Send the message "Hello" (1E240 Hex), 4 times, to pager "123456". ???

Message Name: International paging call with numeric message (15 digits)

Message Element Code: 11

Function: To send an International paging call with a 15 digit numeric message and specify the number of repetitions.

Format:

	MSB	LSB	
MEC	11		
MED	0..F 0..F		Bits 7..4: Number of repetitions (max 15) Bits 3..0: Pager address
MED	0..F 0..F		Bits 7..0: Pager address (MSB)
MED	00..FF		Bits 7..0: Pager address
MED	00..FF		Bits 7..0: Pager address (LSB)
MED	0..9 0..9		Country Code (2 digits)
MED	0..9 0..A		Bits 7..4: Country code (1 digit) Bits 3..0: Message (first 2 digits)
MED	0..A 0..A		Message (next 2 digits)
	:		
	:		
MED	0..A 0..A		Message (last 2 digits)

Conventions: The first Hex number (bits 7..4) of the first byte of the Message Element Data (MED) is used to define the number of repetitions of a paging call. If this number equals 0, the default repetition number shall be used. The second Hex number (bits 3..0) of the first byte of the MED and the next two bytes of the MED, represent 20 bits for Hex coding of the pager address (6 digits). The remainder of the MED contains the 15 digit coded in conformity with CENELEC EN 50067.

Example: <11> <31> <E2> <40> <22> <00> <03> <8A> <61> <A3> <01> <92> <6A>

Send the message "0038 61 301926", 3 times, to pager "123456" in country "220".

Message Name: International paging with functions message

Message Element Code: 10

Function: To send a paging call with a international function message

Format:

	MSB	LSB	
MEC	10		
MED	0..F	0..F	Bits 7..4: Number of repetitions (max 15) Bits 3..0: Pager address (MSB)
MED	00..FF		Bits 7..0: Pager address
MED	00..FF		Bits 7..0: Pager address (LSB)
MED	0..9	0..9	Country code (2 digits)
MED	0..9	0..F	Bits 7..4: Country code (1 digit) Bits 3..0: Message (first character)
MED	0..F	0..F	Message (second and third characters)
MED	0..F	0..F	Message (fourth and fifth characters)
MED	0..F	0..F	Message (sixth and seventh characters)

Conventions: The first Hex number (bits 7..4) of the first byte of the Message Element Data (MED) is used to define the number of repetitions of a paging call. If this number equals 0, the default repetition number shall be used. The second Hex number (bits 3..0) of the first byte of the MED and the next two bytes of the MED, represent 20 bits for Hex coding of the pager address (6 digits). The remainder of the MED contains the seven Hex character message, in conformity with CENELEC EN 50067.

Example: <10> <31> <E2> <40> <78> <9A> <BC> <DE> <F0>

Send the function message "ABCDEF0", three times, to pager "123456" (1E240 Hex) in country "789".

Message Name: Paging transmitter network group designation

Message Element Code: 12

Function: To set the paging transmitter network group designation

Format:

	MSB	LSB
MEC	12	
DSN	00..FF	
MED	00..07	

Conventions: Group designation coding is in conformity with CENELEC EN 50067.

Example: <12> <02> <03>

Set the group designation to 3 (Group code 40-99) in data set 2.

Message Name: Real time clock

Message Element Code: 0D

Function: To set the date and time

Format:

	MSB	LSB	
MEC	0D		
MED	00..63		Last two decimal digits of Year expressed as Hex
MED	00..0C		Month
MED	00..1F		Date
MED	00..18		Hours
MED	00..3B		Minutes
MED	00..3B		Seconds
MED	00..63		Centiseconds
MED	00..3F		Local Time offset

Conventions: The local Time Offset byte should be coded as follows:

MSB								LSB
1	2	3	4	5	6	7	8	
Not Used	Not Used	Sign of Local Time Offset	Magnitude of Local Time Offset in multiples of half hours					
		0 = +						
		1 = -						

Date, hours, minutes, seconds and centiseconds are coded as binary numbers and then expressed as a two digit Hex number. If all fields are set to zero, the 4A groups are transmitted with all zeros.

Example: <08> <5C> <09> <0C> <0A> <12> <21> <0F> <02>

The following is to be set: Year is 1992, Month is September, Date is 12, Hour is 10, Minute is 18, Second is 33, Centisecond is 15 and Local Time offset is 1 hour.

Message Name: Real time clock correction

Message Element Code: 09

Function: To set real time clock correction (RTCC) in order to compensate a delay caused by the signal distribution. The adjustment range is between -32768 ms and +32767 ms.

Format:

	MSB	LSB	
MEC	09		
MED	00..FF		RTCC higher byte Hex
MED	00..FF		RTCC lower byte Hex

Conventions: The RTCC is coded as a 16 Bit two's complement number.

Example: <09> <FF> <C6>

Set Real Time Clock Correction to -58ms.

Message Name: CT on/off

Message Element Code: 19

Function: To enable/disable the transmission of Group Type 4A

Format:

	MSB	LSB	
MEC	19		
MED	00..01		Enable/Disable

Conventions: "01" enables the transmission of Group Type 4A, and "00" disables it. The time is set with the Real Time Clock Command.

Example: <19> <01>

Enable transmission of Group Type 4A.

Message Name: RDS on/off

Message Element Code: 1E

Function: To switch RDS output signal "ON" or "OFF"

Format:

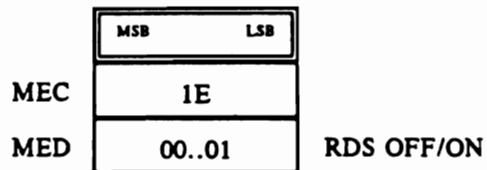

Conventions: "00" switches RDS "OFF", "01" switches "ON"

Example: <1E> <00>

Switch the RDS output signal "OFF".

Message Name: RDS phase

Message Element Code: 22

Function: To set RDS subcarrier phase shift relative to the phase of the 3rd harmonic of the 19 kHz reference signal for a specified Reference Table entry.

Format:

	MSB	LSB	
MEC	22		
MED	0..7 0..E		Bits 7..5: Reference Table entry Bits 4..0: RDS phase MSB
MED	00..FF		RDS phase LSB

Conventions: Reference '0' means that the phase is related to all table entries, '1' to '6' identify a specific table entry, '7' is the currently selected table entry.
The RDS phase is expressed in the range from 0..359.9 degrees, in steps of 0.1 degrees and converted to a Hex number.

Example: <22> <45> <4C>

Set phase to 135.6 degrees for Reference Table entry: Input 4.

Message Name: RDS level

Message Element Code: 26 0E

Function: To adjust the level of the RDS subcarrier in mV_{pp} for a specified Reference Table entry.

Format:

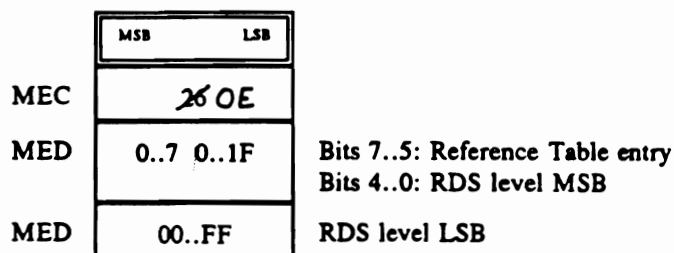

Conventions: Reference "0" means that the level is related to all table entries, "1" to "6" identify a specific table entry, "7" is the currently selected table entry. The RDS level is expressed in the range from 0..8191 mV_{pp} , and converted to a 13 Bit number.

Example: 0E
 <26> <A3> <11>

Set RDS level to 785 mV_{pp} for Reference Table entry: input 5.

Message Name: ARI ON/OFF

Message Element Code: 21

Function: To switch ARI output signal "ON" or "OFF"

Format:

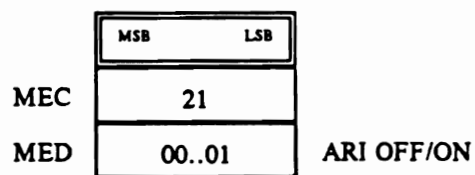

Conventions: "00" switches ARI "OFF", "01" switches ARI "ON".

Example: <21> <00>

Switch the ARI output signal "OFF".

Message Name: ARI area (BK)

Message Element Code: 0F

Function: To set the ARI area code

Format:

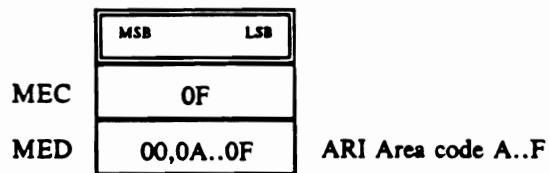

Conventions: "00" switches the ARI Area modulation "OFF".

Example: <0F> <0A>

Switch ARI Area code to A.

Message Name: ARI level

Message Element Code: 1F

Function: To adjust the output level of the ARI subcarrier in mV_{pp} for a specified Reference Table entry.

Format:

	MSB	LSB	
MEC	1F		
MED	0..7	0..1F	Bits 7..5: Reference Table entry Bits 4..0: ARI level MSB
MED	00..FF		ARI level LSB

Conventions: Reference "00" means that the level is related to all table entries, "1" to "6" identify a specific table entry, "7" is the currently selected table entry. The ARI level is expressed in the range from 0..8191 mV_{pp} , and converted to a 13 Bit number.

Example: <1F> <F4> <07>

Set ARI level to 5127 mV_{pp} on all Reference Table entries.

Message Name: Site address

Message Element Code: 23

Function: To load or remove a site address in the encoder.

Format:

	MSB	LSB	
MEC	23		
MED	00..03		Control Bits
MED	00..03		Site address high
MED	00..FF		Site address low

Conventions: The range of permitted site addresses is 001..3FF Hex (10 Bits).
 The global site address "0" is always defined for the encoder. This address does not need to be included in a downloaded address list, and may not be cleared.

Manufacturers may choose to implement a special (individual) site address that cannot be changed or cleared with this command.

Significance of the two control bits:

Bit 1 Bit 0

0	0	remove the specified site address from the list
0	1	add the specified site address to the list
1	0	remove all site addresses
1	1	not used

Example: <23> <10> <00> <48>

Add the site address 0048 Hex to the list of site addresses.

Message Name: Encoder address

Message Element Code: 27

Function: To load or remove an encoder address in the encoder

Format:

	MSB	LSB	
MEC	27		
MED	00..03		Control Bits
MED	01..3F		Encoder address

Conventions: The range of permitted encoder addresses is 01..3F Hex (6 Bits).

The global encoder address "0" is always defined for the encoder. This address does not need to be included in a downloaded address list, and may not be cleared.

Manufacturers may choose to implement a special (individual) encoder address that cannot be changed or cleared with this command.

Significance of the two control bits:

Bit 1 Bit 0

0	0	remove the specified encoder address from the list
0	1	add the specified encoder address to the list
1	0	remove all encoder addresses
1	1	not used

Example: <27> <10> <13>

Add the encoder address 13 (Hex) to the list of encoder addresses.

Message Name: Make PSN list

Message Element Code: 28

Function: To assign one PSN as the main network service in the specified data set(s) and assign the other PSNs as other networks (EON).

Format:

	MSB	LSB	
MEC	28		
DSN	00..FF		
MEL	00..FF		
MED	01..FF		PSN Main service
MED	01..FF		PSN EON service

Conventions: This command establishes the Main service and the EON services which will be utilized in a given data set within the encoder. When issued the command may establish new services which have, until issued, not been referred to before. These services will need to be loaded using appropriate commands and then be enabled using the PSN enable command before the output is transmitted.

Example: <28> <00> <02> <05> <03> <01> <04> <09> <2F>

In data set 2, assign PSN = 3 as the main service and the PSN's 1, 4, 9 and 47 as EON services.

Message Name: PSN Enable/Disable

Message Element Code: 0B

Function: To enable or disable a specified PSN

Format:

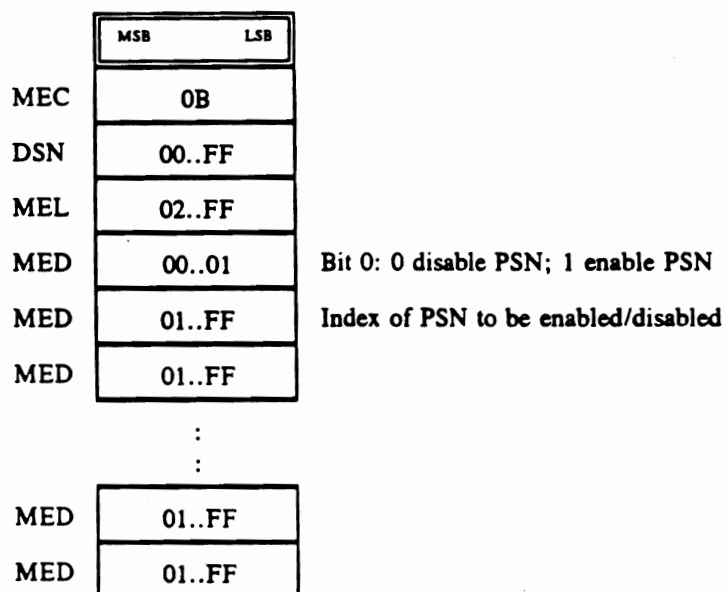

Conventions: The main PSN may not be affected, addressing the main PSN will cause an error code.

Example: <0B> <03> <04> <00> <06> <01> <07>

Disable PSN 6 and enable PSN 7 in Data set 3.

Message Name: Communication mode

Message Element Code: 2C

Function: To set the communication mode of the encoder

Format:

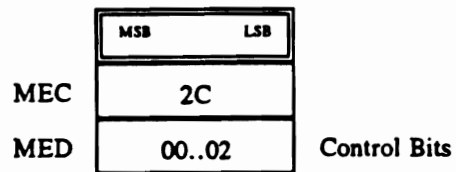

Conventions: 0 means unidirectional mode (see paragraph 2.3.1).
 1 means bi-directional mode with requested response (see paragraph 2.3.2).
 2 means bi-directional mode with spontaneous response (see paragraph 2.3.3).

Example: <2C> <01>

The encoder is set to mode 1.

Message Name: EON TA control

Message Element Code: 15

Function: To control the generation of Group Type 14B in the "ON" and "OFF" transition

Format:

	MSB	LSB	
MEC	15		
MED	00..08		Minimum number of Groups between successive Group Type 14B (0..8) groups
MED	0..F	0..F	Bits 7..4: Number of 14B groups at TA "ON" transition Bits 3..0: Number of 14B groups at TA "OFF" transition

Conventions: In the second MED, 0 specifies that no Group Type 14B shall be transmitted at the given transition. 1..E specify the number of Group Type 14B's to be transmitted at the given transition. F means the Group Type 14B should be transmitted continuously while the respective state is maintained.

Example: <15> <01> <02>

Transmit two Group Type 14B groups, with a gap of "1" between successive Group Type 14B groups, at the TA "off" transition.

Message Name: TA control

Message Element Code: 2A

Function: To control the generation of Group Type 14B in the "ON" and "OFF" transition

Format:

	MSB	LSB	
MEC	2A		
MED	00..08		Minimum number of Groups between successive Group Type 15B (0..8) groups
MED	0..F	0..F	Bits 7..4: Number of 15B groups at TA "ON" transition Bits 3..0: Number of 15B groups at TA "OFF" transition.

Conventions: In the second MED, 0 specifies that no Group Type 15B shall be transmitted at the given transition. 1..E specify the number of Group Type 15B's to be transmitted at the given transition. F means the Group Type 15B should be transmitted continuously while the respective state is maintained.

Example: <2A> <01> <02>

Transmit two Group Type 15B groups, with a gap of "1" between successive Group Type 14B groups, at the TA "off" transition.

Message Name: Reference input select

Message Element Code: 1D

Function: To select the 19 kHz reference input in the encoder and apply levels and phase from corresponding Reference Table entry.

Format:

	MSB	LSB
MEC	1D	
MED	01..06	

Conventions: The Reference Table contains one entry corresponding to each reference input. Each table entry contains RDS level, RDS phase, ARI level (optional) and ARI phase (optional).

Example: <1D> <01>

Reference input number "1" is selected, as well as level and phase parameters for Reference Table entry number 1.

Message Name: Data set select

Message Element Code: 1C

Function: To select desired data set to be active ("on air").

Format:

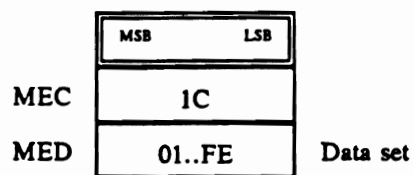

Example: <1C> <17>

Select data set "23" to be active.

Message Name: Group sequence

Message Element Code: 16

Function: To set the group sequence in the specified data set(s)

Format:

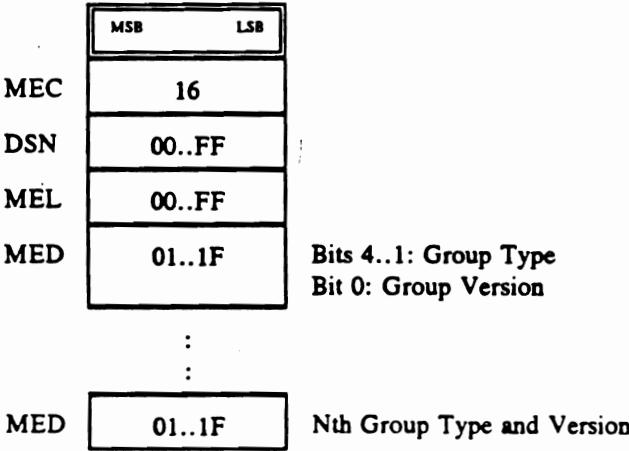

Example: < 16 > < 00 > < 06 > < 00 > < 04 > < 0E > < 1C > < 0D > < 00 >

Set a new group sequence in the current data set 0A, 2A, 7A, 14A, 6B, 0A.

Message Name: Group usage code sequence

Message Element Code: 29

Function: To set the usage code sequence for a specified Group Type in the specified data set(s).

Format:

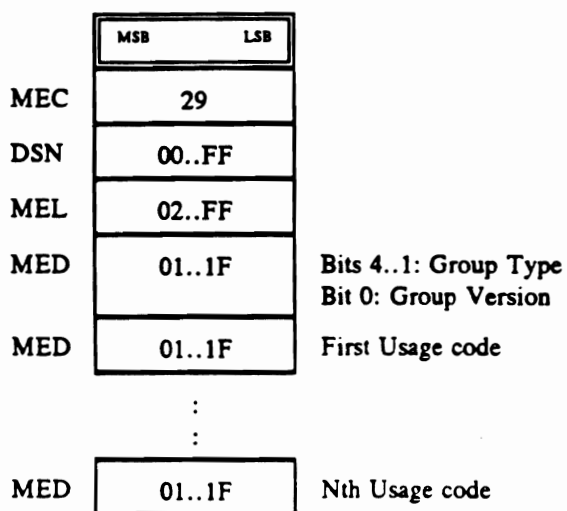

Convention: Group Types 1A and 14A may be used. Other Groups which do not utilize Usage codes will be ignored

Example: <29> <00> <04> <02> <00> <01> <00>

Set a new usage code sequence for Group Type 1A in the current data set: 00, 01, 02.

Message Name: PS character code table selection

Message Element Code: 2F

Function: To select the code table number used by the encoder for PS transmission.

Format:

	MSB	LSB	
MEC	2F		
MED	01..03		Code Table number

Conventions: The encoder has to use the code table as specified in EN 50067 Annex E. Table 1 (Fig. 2.1, Annex E) is default.

Example: <2F> <02>

Use code table of Figure E.2 in annex E of CENELEC EN 50067.

Message Name: Message acknowledgement

Message Element Code: 18

Function: Messages used to report acknowledgement of received messages.

Format:

	MSB	LSB	
MEC	18		
MED	00..FF		Response Code
MED	00..FF		Sequence counter number

Conventions: The response code is as follows:

- 0 = Message received OK
- 1 = CRC error has occurred. Message is wrong
- 2 = Message was not received (derived from the sequence counter)
- 3 = Message unknown
- 4 = DSN is out of range
- 5 = PSN is out of range
- 6 = Parameter out of range
- 7 = Message element length error
- 8 = Message field length error
- 9 = Message not acceptable
- 10-255 = Undefined

The Sequence counter number is a copy of sequence counter of received message reflected by the response. This field is sent only if an error occurred, otherwise, if transmission is OK, this field is not transmitted. In this case, response reflects to last message (bi-directional communication mode 2) or to all messages after last response (bi-directional communication mode 1).

Example: <18> <00> <25>

In the bi-directional mode 1: All messages after the last response were correctly received.
In the bi-directional mode 2: The last message was correctly received.

<18> <02> <42> means that sequence number 42 hex is wrong.

Message Name: Request message

Message Element Code: 17

Function: To request specific message to be replied by the encoder

Format:

	MSB	LSB	
MEC	17		
MEL	01..FF		
MED	00..FF		Code of requested message
MED	00..FF		[DSN]
MED	00..FF		[PSN]

Conventions: The Request Message code is the code of a message to be answered, i.e. most Message Element Codes can be requested, in the same format as described.

The presence of [DSN] and [PSN] is dependent on the Request Message code, and [DSN] and [PSN] are included in conformity with the code that is requested.

Example: <17> <01> <1A>

Means that the Request message code is 1A.

Message Name: Manufacturer's specific command

Message Element Code: 2D

Function: The content and meaning of this command is manufacturer dependent.

Format:

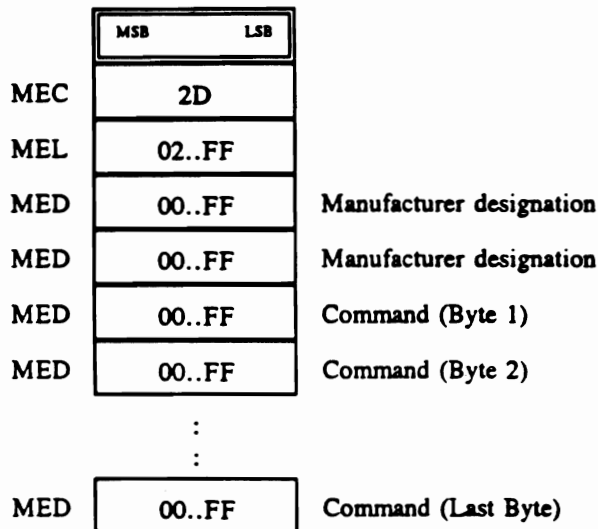

Conventions: This command can be used by the manufacturer to implement any manufacturer's dependent special feature. The manufacturer's designation consists of two bytes. The meaning of the command must be specified by the manufacturer.

Example: <2D> <06> <4D> <41> <12> <34> <56> <78>

The "MA" manufacturer's specific command having a length of 4 bytes.

Appendix 1

CCITT Polynomial

1. Introduction

The CRC is a cyclic redundancy check carried out on data to allow error checking to take place.

The field consists of four hexadecimal characters representing a 16 bit calculation. The divisor polynomial used to generate the CRC is:

$$x^{16} + x^{12} + x^5 + 1$$

The CRC calculation starts with the most significant bit of the field immediately following the start character and ends with the least significant bit of the character immediately preceding the first CRC character.

The CRC is initialised to a value of OFFF(hex) and the four CRC characters are formed from the INVERSE of the result of the CRC calculation. The four most significant bits are represented by the first CRC field character.

2. PASCAL listing of CCITT CRC calculation routine

Type STRING is a PACKED ARRAY of CHAR with zero'th element holding the length of the string:

SWAP is a library function which swaps the high- and low-order bytes of the argument e.g.

```
VAR X: WORD;  
  
BEGIN  
  X:= SWAP ($1234)   [$3412]  
END;
```

LO is a library function which returns the low-order byte of the argument e.g.

```
VAR W: WORD;  
  
BEGIN  
  W:= LO ($1234)    [$34]  
END;
```

```
FUNCTION CRCVALUE (STRINGTOEVAL : STRING): INTEGER;
```

```
VAR
```

```
COUNT: BYTE;  
TEMPCRC: WORD;
```

```
BEGIN
```

```
    TEMPCRC:= $FFFF;
```

```
    FOR COUNT:= 1 TO LENGTH (STRINGTOEVAL) DO
```

```
        BEGIN
```

```
            TEMPCRC:= SWAP (TEMPCRC) XOR ORD (STRINGTOEVAL [COUNT]);
```

```
            TEMPCRC:= TEMPCRC XOR (LO (TEMPCRC) SHR 4);
```

```
            TEMPCRC:= TEMPCRC XOR (SWAP (LO (TEMPCRC)) SHL 4) XOR  
                (LO (TEMPCRC) SHL 5)
```

```
        END;
```

```
    CRCVALUE:= TEMPCRC XOR $FFFF
```

```
END; [OF FUNCTION CRCVALUE]
```

3. Example

When applied to the string

2D111234010105ABCD123FOXXX11069212491000320066

the CRC generated and appended will be 9723.

Appendix 2

Glossary

Clock-time and date (CT)

In application of the relevant CCIR Recommendations, broadcast time and date codes should use Coordinated Universal Time (UTC) and Modified Julian Day (MJD). Details of using these codes are given in 3.2.3 and annex G of CENELEC EN 50067. The listener, however, will not use this information directly and the conversion to local time and date will be made in the receiver's circuitry.

Decoder identification (DI)

This is a switching signal indicating which of 16 possible operating modes (or combinations thereof) is appropriate for use with the broadcast signals.

Emergency warning systems (EWS)

The EWS feature is intended to provide for the coding of warning messages that for reasons of secrecy cannot be fully detailed. These messages will be broadcast only in cases of extreme emergency and will only be evaluated by special receivers that will automatically tune to the channel carrying the corresponding identification (see 3.2.7 of CENELEC EN 50067).

Enhanced other networks information (EON)

This feature can be used to update the information stored in a receiver about programme services other than the one received. Alternative frequencies, the PS name, Traffic-programme and announcement identification as well as Programme-type and Programme-item-number information can be transmitted for each other service. The relation to the corresponding programme is established by means of the relevant programme identification (see 3.2.1.8 of CENELEC EN 50067). Linkage information (see 3.2.1.8.3 of CENELEC EN 50067), consisting of four data elements, provides the means by which several programme services may be treated by the receiver as a single service during times a common programme is carried.

In-house application (IH)

This refers to data to be decoded only within the broadcasting organisation. Some examples noted are identification of transmission origin, remote switching of networks and paging of staff. The applications of coding may be decided by each broadcasting organisation itself.

List of alternative frequencies (AF)

The list(s) of alternative frequencies give information on the various transmitters broadcasting the same programme in the same or adjacent reception areas, and enable receivers equipped with a memory to store the list(s), to reduce the time for switching to another transmitter. This facility is particularly useful in the case of car and portable radios. One of two Methods, A or B, can be used. Their protocols are explained in 3.2.1.6.2 of CENELEC EN 50067.

Programme identification (PI)

This information consists of a code enabling the receiver to distinguish between countries, areas in which the same programme is transmitted, and the identification of the programme itself. The code is not intended for direct display and is assigned to each individual radio programme, to enable it to be distinguished from all other programmes. One important application of this information would be to enable the receiver to search automatically for an alternative frequency in case of bad reception of the programme to which the receiver is tuned; the criteria for the change-over to the new frequency would be the presence of a better signal having the same programme identification code.

Music/speech switch (M/S)

This is a two-state signal to provide information on whether music or speech is being broadcast. The signal would permit receivers to be equipped with two separate volume controls, one for music and one for speech, so that the listener could adjust the balance between them to suit his individual listening habits.

Programme-item number (PIN)

The code should enable receivers and recorders designed to make use of this feature to respond to the particular programme item(s) that the user has preselected. Use is made of the scheduled programme time, to which is added the day of the month in order to avoid ambiguity (see 3.2.1.7 of CENELEC EN 50067).

Programme service (PS) name

This is a text consisting of not more than eight alphanumeric characters coded in accordance with annex E of CENELEC EN 50067, which is displayed by RDS receivers in order to inform the listener what programme service is being broadcast by the station to which the receiver is tuned. An example for a name is "Radio 21". In the case of a local programme, the broadcaster may use any designation (up to 8 characters).

Programme type (PTY)

This is an identification number to be transmitted with each programme and which is intended to specify the programme type within 31 possibilities (see annex F of CENELEC EN 50067). This code could also be used for search tuning. The code will, moreover, enable suitable receivers and recorders to be pre-set to respond only to programme items of the desired type. The last number, i.e. 31, is reserved for an alarm identification which is intended to switch on the audio signal when a receiver is operated in a waiting reception mode.

Radio paging (RP)

The RP Feature is intended to provide radio paging using the existing VHF/FM broadcasts as a transport mechanism, thereby avoiding the need for a dedicated network of transmitters. Subscribers to a paging service will require a special pocket paging receiver in which the subscriber address code is stored. Four types of call messages are possible, in principle:

- a simple call (beeper) without message,
- a 10 or 18 digit numeric message, restricted to 15 digits in international paging,

- an alphanumeric message of up to 80 characters,
- a functions message in international paging.

The detailed coding protocols are given in 3.2.6 of CENELEC EN 50067.

Traffic Message Channel (TMC)

This feature is intended to be used for the coded transmission of traffic information. Group type 8A is reserved for this purpose and details are still under discussion (see 3.1.3 of CENELEC EN 50067).

Radiotext (RT)

This refers to text transmissions coded in accordance with annex E, primarily addressed to new home receivers, which would be equipped with suitable display facilities (see 3.2.2). In car receivers where a text display is undesirable for safety reasons, the radiotext transmission could be used to control a speech synthesizer; details of operation in this mode require further study.

Traffic-announcement identification (TA)

This is an on/off switching signal to indicate whether an announcement for motorists is on the air. The signal could be used in receivers to:

- a) switch automatically from any audio mode to the traffic announcement;
- b) switch on the traffic announcement automatically when the receiver is in a waiting reception mode and the audio signal is muted;
- c) switch from a programme carrying no traffic information to one carrying a traffic announcement, according to those possibilities which are given in 3.2.1.3 or 3.2.1.8.2 of CENELEC EN 50067.

After the end of the traffic announcement the initial operating mode will be restored.

Traffic-programme identification (TP)

This is an on/off switching signal to indicate, by means of a special lamp (or a similar device) on the receiver, that this is a programme on which announcements are usually made for motorists. The signal could be taken into account during automatic search tuning.

Transparent data channel (TDC)

As well as for the application described above, radiotext could also be sent in a form suitable for presenting a display on a television receiver similar to that obtained with teletext. These channels may be used to send alphanumeric characters, or other text (including mosaic graphics), or for transmission of computer programs and similar data not for display.

Index of abbreviations

The abbreviations which are commonly used in context with the Radio Data System are listed below in alphabetical order. Most of these terms are explained in the glossary (see 4).

a) RDS features:

AF	List of alternative frequencies
CT	Clock time and date
DI	Decoder identification
EON	Enhanced information on other networks
EWS	Emergency warning systems
IH	In-house application
M/S	Music/speech switch
PI	Programme identification
PIN	Programme-item number
PS	Programme service name
PTY	Programme type
RDS	Radio Data System
RP	Radio paging
RT	Radiotext
TA	Traffic-announcement identification
TDC	Transparent data channel
TMC	Traffic message channel (Application under discussion)
TP	Traffic-programme identification

b) Other abbreviations:

ARI	Identification system for broadcasts to motorists (CCIR Report 463 and annex H of CENELEC EN 50067)
CI	Country identifier (see 3.2.1.8.3 of CENELEC EN 50067)
ECC	Extended country code (see annex D of CENELEC EN 50067)
EG	Extended Generic indicator (see 3.2.1.8.3 of CENELEC EN 50067)
ILS	International Linkage Set indicator (see 3.2.1.8.3 of CENELEC EN 50067)
LA	Linkage Actuator (see 3.2.1.8.3 of CENELEC EN 50067)
LI	Linkage Identifier (see 3.2.1.8.3 of CENELEC EN 50067)
LSN	Linkage Set Number (see 3.2.1.8.3 of CENELEC EN 50067)



ROHDE & SCHWARZ

Communications
Division

Operating Manual

Request Protocol for Coder

**RDS CODEC
DMC01 and DMC01C**

Printed in the Federal
Republic of Germany

)

)

)

)

**Operation Coder DMC01
Request Protocol**

Contents

1	Introduction		
1.1	Transmission Format		5
1.2	Notation		5
1.3	Conventions		5
Fig. 1	Syntax		5
2	List of all Commands Defined		6
3	Message description		
	Request Program identification PI	17/01	8
	Request Program service name PS	17/02	8
	Request Traffic announcement/Traffic program (TA/TP bits)	17/03	9
	Request Decoder information bits DI	17/04	9
	Request Music / speech switch M/S	17/05	10
	Request Program-item number PIN	17/06	10
	Request Programme type PTY	17/07	11
	Request Real time clock correction	17/09	11
	Request Radiotext RT	17/0A	12
	Request Real time clock	17/0D	12
	Request RDS level	17/0E	13
	Request ARI area (BK)	17/0F	13
	Request Paging transmitter network group designation	17/12	14
	Request Group sequence	17/16	14
	Request Clock time and date status CT	17/19	15
	Request Slow Labelling codes	17/1A	15
	Request Data set select	17/1C	16
	Request Ref. input select	17/1D	16
	Request RDS status	17/1E	17
	Request ARI level	17/1F	17
	Request ARI status	17/21	18
	Request RDS phase	17/22	18
	Request Site address	17/23	19
	Request Free-format group	17/24	19
	Request In-house information IH	17/25	20
	Request Transparent data channel TDC	17/26	20
	Request Encoder address	17/27	21
	Request Group usage code sequence	17/29	21
	Request Emergency warning system data EWS	17/2B	22
	Request Linkage information LA	17/2E	22

)

)

)

)

1 Introduction

Commands and data are written and transmitted in ASCII. Basically the command syntax is the same for all information handled and complies with the EBU Universal Encoder Communication Protocol.

Each command consists of an EBU prolog, the command proper (EBU message) and the EBU epilog. The EBU message assigned to code 17 is available for request commands.

1.1 Transmission Format

A frame comprises a series of bytes, delimited by two reserved bytes (STA = FE and STP = FF), which mark the beginning and end of the frame. Each frame contains a destination address (ADD), defining the set of encoders to which the record is being sent. A sequence counter (SQC) labels each separate record. The message itself is preceded by a byte defining the message length (MFL) and followed by a CRC check.

Part	De-scriptor	Description	Length
EBU Prolog	STA	Start	1 byte
	ADD	Address	2 bytes
	SQC	Sequence Counter	1 byte
	MFL	Message Field Length	1 byte
EBU Message	MSG	Message	0 to 255 bytes
	MEC	Message Element Code	1 byte
	MEL	Message Element Data Length	1 byte
	MED	Command to be requested	1 byte
	[DSN]	Data Set Number	1 byte
	[PSN]	Program Service Number	1 byte
[MED]	Message Element Data		
EBU Epilog	###	Cyclic Redundancy Check	2 bytes
	STP	Stop	1 byte

Fields and whole message elements shown in brackets are optional. They are used, as required by the specific command.

1.2 Notation

De-scriptor	Values		Explanation
	MSB	LSB	
MEC	17		Message Element Code (2D)
MEL	00 to FF		Message Element Data Length
MED	00 to FF		EBU Command to be requested
[DSN]	00 to FF		Data Set Number
[PSN]	00to09		Program Service Number
[MED]	00 to FF		(parameter)
:	:		

The message description is made according to the above diagram.

The first column indicates the descriptor of the message which is detailed in the table.

Second column: Each element in the table represents one byte where the bits are numbered from 7 to 0 (from left to right). For transmission of a respective message each byte is represented by two HEX symbols of which the permitted range is indicated in the respective element.

The third column gives an information of the context of the table.

1.3 Conventions

The Request Message is the code of a message to be answered, i.e. most Message Element Codes can be requested, in the same format as described. The presence of [DSN] and [PSN] is dependent on the Request Message code, and [DSN] and [PSN] are included in conformity with the code that is requested.

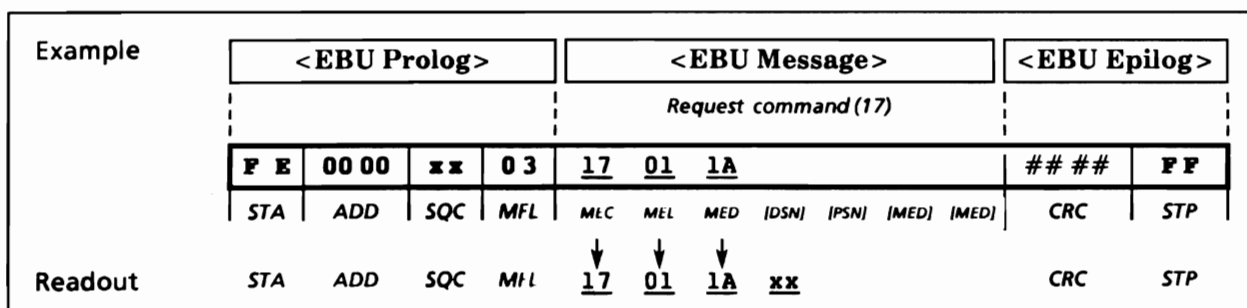

Fig. 1 Syntax

2 List of all Commands Defined

Request Commands

Function	Information	Command			Parameter
		EBU	Manufacturer		
		MEC	MEL	Code of requested message	
Request Program identification	PI	17	03	01	1st byte: Data set number (DSN) 2nd byte: Program service number (PSN) Return: see EBU command 01
Request Program service name	PS	17	03	02	1st byte: Data set number (DSN) 2nd byte: Program service number (PSN) Return: see EBU command 02
Request Traffic announcement and Traffic program bits	TA/TP	17	03	03	1st byte: Data set number (DSN) 2nd byte: Program service number (PSN) Return: see EBU command 03
Request Decoder information bits	DI	17	03	04	1st byte: Data set number (DSN) 2nd byte: Program service number (PSN) Return: see EBU command 04
Request Music/speech switch	M/S	17	03	05	1st byte: Data set number (DSN) 2nd byte: Program service number (PSN) Return: see EBU command 05
Request Program item number	PIN	17	03	06	1st byte: Data set number (DSN) 2nd byte: Program service number (PSN) Return: see EBU command 06
Request Programme type information	PTY	17	03	07	1st byte: Data set number (DSN) 2nd byte: Program service number (PSN) Return: see EBU command 07
Request Real time clock correction		17	01	09	Return: see EBU command 09
Request Radiotext	RT	17	03	0A	1st byte: Data set number (DSN) 2nd byte: Program service number (PSN) Return: see EBU command 0A
Request Real time clock	CT	17	01	0D	Return: see EBU command 0D
Request RDS level	RDS	17	02	0E	1st byte: Reference table entry Return: see EBU command 0E
Request ARI area (BK)	ARI	17	01	0F	Return: see EBU command 0F
Request Paging transmitter network group designation		17	02	12	1st byte: Data set number (DSN) Return: see EBU command 12
Request Group sequence	GS	17	02	16	1st byte: Data set number (DSN) Return: see EBU command 16
Request Clock time on/off	CT	17	01	19	Return: see EBU command 19

Note:

Data set number DSN:

00 Current data set
01 to 09 data set 1 to 9
FE Not used with Request command
FF Not used with Request command

Program service number PSN:

00 Special PSN for main service of specified data set(s)
01 to FF Specific service within data set(s), p.e. EON information

**Operation Coder DMC01
Request Protocol**

Request Commands (cont.)

Function	Information	Command			Parameter
		EBU	Manufacturer		
		MEC	MEL	Code of requested message	
Request Slow labelling codes		17	02	1A	1 st byte: Data set number (DSN) <u>Return:</u> see EBU command 1A
Request Data set select	DS	17	01	1C	<u>Return:</u> see EBU command 1C
Request Ref. input select (number of current reference table entry)		17	01	1D	<u>Return:</u> see EBU command 1D
Request RDS status	RDS	17	01	1E	<u>Return:</u> see EBU command 1E
Request ARI level	ARI	17	02	1F	1 st byte: Reference table entry <u>Return:</u> see EBU command 1F
Request ARI status	ARI	17	01	21	<u>Return:</u> see EBU command 21
Request RDS phase	RDS	17	02	22	1 st byte: Reference table entry <u>Return:</u> see EBU command 22
Request Site address		17	01	23	<u>Return:</u> see EBU command 23
Request Free-format group		17	02	24	1 st byte: Bits 4 to 1: Group number Bit 0: Group version A/B <u>Return:</u> see EBU command 24
Request In-house information	IH	17	02	25	1 st byte: 00 = Group version A 01 = Group version B <u>Return:</u> see EBU command 25
Request Transparent data channel	TDC	17	04	26	1 st byte: 02 2 nd byte: 00 = Group version A 01 = Group version B 3 rd byte: 00 to 1F = Channel <u>Return:</u> see EBU command 26
Request Encoder address (user address)		17	01	27	<u>Return:</u> see EBU command 27
Request Group usage code sequence		17	04	29	1 st byte: Data set number (DSN) 2 nd byte: 01 3 rd byte: Bits 4 to 1: Group number Bit 0: Group version A/B <u>Return:</u> see EBU command 29
Request Emergency warning system	EWS	17	01	2B	<u>Return:</u> see EBU command 2B
Request Linkage information	LA	17	03	2E	1 st byte: Data set number (DSN) 2 nd byte: program service number (PSN) <u>Return:</u> see EBU command 2E

3 Message description

Message Name: Request Program identification PI

Message Element Code: 17 / 01

Function: Request PI code of the specified programme service(s) of the specified data set(s)

Format:

	MSB	LSB	
MEC	17		
MEL	03		
MED	01		Code of requested message
MED	00 to 09		DSN
MED	00 to FF		PSN

Example <17><03><01><00><01>

Message Name: Request Program service name PS

Message Element Code: 17 / 02

Function: Request the PS name of the the specified programme service(s) of the specified data set(s)

Format:

	MSB	LSB	
MEC	17		
MEL	03		
MED	02		Code of requested message
MED	00 to 09		DSN
MED	00 to FF		PSN

Example <17><03><02><00><02>

**Operation Coder DMC01
Request Protocol**

Message Name: Request Traffic announcement/Traffic program (TA/TP bits)

Message Element Code: 17 / 03

Function: Request the Traffic announcement and Traffic Programme bits

Format:

	MSB	LSB	
<i>MEC</i>	17		
<i>MEL</i>	03		
<i>MED</i>	03		<i>Code of requested message</i>
<i>MED</i>	00 to 09		<i>DSN</i>
<i>MED</i>	00 to FF		<i>PSN</i>

Example <17> <03> <03> <00> <05>

Message Name: Request Decoder information bits DI

Message Element Code: 17 / 04

Function: Request the Decoder information bits of the specified programme service of the specified data set(s)

Format:

	MSB	LSB	
<i>MEC</i>	17		
<i>MEL</i>	03		
<i>MED</i>	04		<i>Code</i>
<i>MED</i>	00 to 09		<i>DSN</i>
<i>MED</i>	00 to FF		<i>PSN</i>

<u>Operating information for the receiver decoder</u>	
00	Mono
01	Stereo
02	Not yet assigned
03	Stereo dummy head
04	Mono compressed
05	Stereo compressed
06	Not yet assigned
07	Stereo compressed (dummy head)
08 to 0F	Not yet assigned

Example <17> <03> <04> <00> <03>

Operation Coder DMC01
Request Protocol

Message Name: Request Music / speech switch M/S

Message Element Code: 17 / 05

Function: Request the M/S flag of the specified programme service of the specified data set

Format:

	MSB	LSB	
MEC	17		
MEL	03		
MED	05		<i>Code of requested message</i>
MED	00 to 09		<i>DSN</i>
MED	00 to FF		<i>PSN</i>

Example <17> <03> <05> <00> <01>

Message Name: Request Program-item number PIN

Message Element Code: 17 / 06

Function: Request the PIN code of the specified programme service of the specified data set(s)

Format:

	MSB	LSB	
MEC	17		
MEL	03		
MED	06		<i>Code of requested message</i>
MED	00 to 09		<i>DSN</i>
MED	00 to FF		<i>PSN</i>

Example <17> <03> <06> <00> <06>

**Operation Coder DMC01
Request Protocol**

Message Name: Request Programme type PTY

Message Element Code: 17 / 07

Function: Request the Programme Type information of the specified programme service and of the specified data set

Format:

	MSB	LSB	
MEC	17		
MEL	03		
MED	07		Code
MED	00 to 09		DSN
MED	00 to FF		PSN

Programme Type information:

00	no program type or undefined
01	NEWS
02	AFFAIRS
03	INFO
04	SPORT
05	EDUCATE
06	DRAMA
07	CULTURE
08	SCIENCE
09	VARIED
0A	POP M
0B	ROCK M
0C	M.O.R. M
0D	LIGHT M
0E	CLASSICS
0F	OTHER M
10 to 1E	not yet assigned
1F	Alarm

Example <17><03><07><00><05>

Message Name: Request Real time clock correction

Message Element Code: 17 / 09

Function: Request the Real time clock correction (RTCC).

Format:

	MSB	LSB	
MEC	17		
MEL	01		
MED	09		Code of requested message

Example <17><01><09>
(The range is between - 32 768 ms and + 32 767 ms)

Operation Coder DMC01
Request Protocol

Message Name: Request Radiotext RT

Message Element Code: 17 / 0A

Function: Request the Radiotext of the specified programme service and of the specified data set

Format:

	MSB	LSB	
MEC	17		
MEL	03		
MED	0A		Code of requested message
MED	00 to 09		DSN
MED	00 to FF		PSN

Example <17> <03> <0A> <00> <01>

Message Name: Request Real time clock

Message Element Code: 17 / 0D

Function: Request the real time

Format:

	MSB	LSB	
MEC	17		
MEL	01		
MED	0D		Code of requested message

Example <17> <01> <0D>

**Operation Coder DMC01
Request Protocol**

Message Name: Request RDS level

Message Element Code: 17 / 0E

Function: Request the level of the RDS subcarrier

Format:

	MSB	LSB	
MEC	17		
MEL	02		
MED	0E		Code of requested message
MED	20, 40, to C0, E0		Ref. table entry

Input for ref. table entry

Hex	Function
20	Table entry 1
40	Table entry 2
60	Table entry 3
80	Table entry 4
A0	Table entry 5
C0	Table entry 6
E0	current table entry

Ref. table entry

Bit number	Function
7654 3210	
000x xxxx	all table entries
001x xxxx	Table entry 1
010x xxxx	Table entry 2
011x xxxx	Table entry 3
100x xxxx	Table entry 4
101x xxxx	Table entry 5
110x xxxx	Table entry 6
111x xxxx	current table entry

Example <17><02><0E><E0>

Message Name: Request ARI area (BK)

Message Element Code: 17 / 0F

Function: Request ARI area code

Format:

	MSB	LSB	
MEC	17		
MEL	01		
MED	0F		Code of requested message

Example <17><01><0F>

Operation Coder DMC01
Request Protocol

Message Name: Request Paging transmitter network group designation

Message Element Code: 17 / 12

Function: Request the Paging transmitter network group designation

Format:

	MSB	LSB	
MEC	17		
MEL	02		
MED	12		Code of requested message
MED	00 to 09		DSN

Conventions: Group designation coding is in conformity withh CENELEC EN 50067

Example <17><02><12><02>

Message Name: Request Group sequence

Message Element Code: 17 / 16

Function: Request the grop sequence of the specified data set

Format:

	MSB	LSB	
MEC	17		
MEL	02		
MED	16		Code of requested message
MED	00 to 09		DSN

Example <17><02><16><00> (Request Group sequence of the current data set)

Operation Coder DMC01
Request Protocol

Message Name: Request Clock time and date status CT

Message Element Code: 17 / 19

Function: Request the transmission mode of Group Type 4A (on/off)
(00 = disabled; 01 = enabled)

Format:

	MSB	LSB	
MEC	17		
MEL	01		Code of requested message
MED	19		DSN

Example <17><01><19>

Message Name: Request Slow Labelling codes

Message Element Code: 17 / 1A

Function: Request the slow labelling codes in group type 1A, block 3

Format:

	MSB	LSB	
MEC	17		
MEL	02		
MED	1A		Code of requested message
MED	00 to 09		DSN

Example <17><02><1A><04>

Operation Coder DMC01
Request Protocol

Message Name: Request Data set select

Message Element Code: 17 / 1C

Function: Request the active data set (on air)

Format:

	MSB	LSB	
MEC	17		
MEL	01		
MED	1C		Code of requested message

Example <17><01><1C>

Message Name: Request Ref. input select

Message Element Code: 17 / 1D

Function: Request entry number of the current reference table
(RDS level, RDS phase, ARI level and ARI phase)

Format:

	MSB	LSB	
MEC	17		
MEL	02		
MED	1D		Code of requested message

Example <17><02><1D><01>

Operation Coder DMC01
Request Protocol

Message Name: Request RDS status

Message Element Code: 17 / 1E

Function: Request the RDS status (on/off)
(00 = off; 01 = on)

Format:

	MSB	LSB	
<i>MEC</i>	17		
<i>MEL</i>	01		
<i>MED</i>	1E		<i>Code of requested message</i>

Example <17> <01> <1E>

Message Name: Request ARI level

Message Element Code: 17 / 1F

Function: Request the level of the ARI subcarrier

Format:

	MSB	LSB	
<i>MEC</i>	17		
<i>MEL</i>	02		
<i>MED</i>	1F		<i>Code of requested message</i>
<i>MED</i>	20, 40, to C0, E0		<i>Ref. table entry</i>

Input for ref. table entry

Hex	Function
20	Table entry 1
40	Table entry 2
60	Table entry 3
80	Table entry 4
A0	Table entry 5
C0	Table entry 6
E0	current table entry

Ref. table entry

Bit number	Function
7654 3210	
000x xxxx	all table entries
001x xxxx	Table entry 1
010x xxxx	Table entry 2
011x xxxx	Table entry 3
100x xxxx	Table entry 4
101x xxxx	Table entry 5
110x xxxx	Table entry 6
111x xxxx	current table entry

Example <17> <02> <1F> <E0>

**Operation Coder DMC01
Request Protocol**

Message Name: Request ARI status

Message Element Code: 17 / 21

Function: Request ARI status (on/off)
(00 = off; 01 = on)

Format:

	MSB	LSB	
MEC	17		
MEL	01		
MED	21		Code of requested message

Example <17><01><21>

Message Name: Request RDS phase

Message Element Code: 17 / 22

Function: Request the RDS subcarrier phase shift relative to the phase of the 3rd harmonic of the 19 kHz reference signal

Format:

	MSB	LSB	
MEC	17		
MEL	02		
MED	22		Code of requested message
MED	20, 40, to C0, E0		Ref. table entry

Input for ref. table entry

Hex	Function
20	Table entry 1 40 Table entry 2
60	Table entry 3 80 Table entry 4
A0	Table entry 5 C0 Table entry 6
E0	current table entry

Ref. table entry

Bit number	Function
7654 3210	
000x xxxx	all table entries
001x xxxx	Table entry 1
010x xxxx	Table entry 2
011x xxxx	Table entry 3
100x xxxx	Table entry 4
101x xxxx	Table entry 5
110x xxxx	Table entry 6
111x xxxx	current table entry

Example <17><02><22><E0>

Operation Coder DMC01
Request Protocol

Message Name: Request Site address

Message Element Code: 17 / 23

Function: Request all site addresses stored in the encoder
Format:

	MSB	LSB	
MEC	17		
MEL	01		
MED	23		Code of requested message

Example <17><01><23>

Message Name: Request Free-format group

Message Element Code: 17 / 24

Function: Request the buffer of the Free-format group

Format:

	MSB	LSB	
MEC	17		
MEL	02		
MED	24		Code of requested message
MED	00 to 1F		Bits 4 to 1: Group Type number Bit 0: Group version A or B

Input for group number		
Bit number	Function	
76543210		
000x xxx0	Group version A	
000x xxx1	Group version B	
0000 000y	Group type 0	
0000 001y	Group type 1	
⋮	⋮	
0011 111y	Group type 15	

Example <17><02><24><07> (Data from Group Type 3B)

**Operation Coder DMC01
Request Protocol**

Message Name: Request In-house information IH

Message Element Code: 17 / 25

Function: Request the in-house applications

Format:

	MSB	LSB	
MEC	17		
MEL	02		
MED	25		<i>Code of requested message</i>
MED	00 to 01		00 = Group Version A 01 = Group Version B

Example <17><02><25><00>

Message Name: Request Transparent data channel TDC

Message Element Code: 17 / 26

Function: Request the data of the Transparent data channel

Format:

	MSB	LSB	
MEC	17		
MEL	04		
MED	26		<i>Code of requested message</i>
MED	02		
MED	00 to 01		00 = Group Version A 01 = Group Version B
MED	00 to 1F		<i>Channel</i>

Example <17><04><26><02><01><1F>

**Operation Coder DMC01
Request Protocol**

Message Name: Request Encoder address

Message Element Code: 17 / 27

Function: Request all encoder addresses stored in the encoder

Format:

	MSB	LSB	
<i>MEC</i>	17		
<i>MEL</i>	01		
<i>MED</i>	27		<i>Code of requested message</i>

Example <17><01><27>

Message Name: Request Group usage code sequence

Message Element Code: 17 / 29

Function: Request the usage code sequence of a specified Group Type in the specified data set.

Format:

	MSB	LSB	
<i>MEC</i>	17		
<i>MEL</i>	04		
<i>MED</i>	29		<i>Code of requested message</i>
<i>MED</i>	00 to 09		<i>DSN</i>
<i>MED</i>	01		<i>Bits 4 to 1: Group Type (x)</i>
<i>MED</i>	01 to 1F		<i>Bit 0: Group Version (y)</i>

<i>Input for group number</i>		
Bit number	Function	
7654 3210		
000x xxx0	Group version A	
000x xxx1	Group version B	
0000 000y	Group type 0	
0000 001y	Group type 1	
⋮	⋮	
0001 111y	Group type 15	

Example <17><04><29><00><01><02>
(Request usage code sequence for Group Type 1A in the current data set)

Operation Coder DMC01
Request Protocol

Message Name: Request Emergency warning system data EWS

Message Element Code: 17 / 2B

Function: Request the Emergency warning system data (37 bits) in group type 9A

Format:

	MSB	LSB	
MEC	17		
MEL	01		
MED	2B		Code of requested message

Example <17><01><2B>

Message Name: Request Linkage information LA

Message Element Code: 17 / 2E

Function: Request the linkage activator in variant 12 of blocks 3 of type 14A groups
(The linkage activator is also in group type 1A, block 3)

Format:

	MSB	LSB	
MEC	17		
MEL	03		
MED	2E		Code of requested message
MED	00 to 09		DSN
MED	00 to FF		PSN

Example <17><03><2E><02><03>



ROHDE & SCHWARZ

Communications
Division

Operating Manual

Manufacturer's Specific Commands for Coder

**RDS CODEC
DMC01 and DMC01C**

Printed in the Federal
Republic of Germany

)

)

)

)

Contents

1	Introduction		
1.1	Transmission Format		5
1.2	Entry		5
1.3	Notation		5
1.4	Output Format		5
Fig. 1	Syntax		5
2	List of all Commands Defined		
	Set Commands		6
	Request Commands		7
	Status Commands		7
3	Message description		
3.1	Set Commands		8
	Set VRF information DK	2D / FE 00	8
	Set Data mode (RDS / Test)	2D / FE 01	8
	Set Test data (1 RDS group)	2D / FE 02	9
	Set Serial interfaces - Baudrate	2D / FE 03	9
	Set Serial interfaces - Hardware Handshake (on/off)	2D / FE 04	10
	Set Parallel interface - Outputs	2D / FE 05	10
	Set Phase RDS / VRF (0°/90°)	2D / FE 06	11
3.2	Request Commands		12
	Request Protocol type	2D / FF 40	12
	Request Serial number	2D / FF 41	12
	Request Ident number	2D / FF 42	13
	Request Coder type	2D / FF 43	13
	Request Firmware version	2D / FF 44	14
	Request Physical address	2D / FF 45	14
	Request Battery check	2D / FF 46	15
3.3	Status Commands		16
	Status Protocol type	2D / FD00	16
	Status Firmware version	2D / FD01	16
	Status Battery check	2D / FD02	16
4	List of all defined Test Commands		17

)

)

)

)

1 Introduction

Commands and data are written and transmitted in ASCII. Basically the command syntax is the same for all information handled and complies with the EBU Universal Encoder Communication Protocol.

Each command consists of an EBU prolog, the command proper (EBU message) and the EBU epilog. The EBU message assigned to code 2D is available for special commands which are defined by the manufacturer as they are not included in the standard EBU protocol.

1.1 Transmission Format

The transmission format is described in the EBU Universal Encoder Communication Protocol and has the following elements:

Part	De- scriptor	Description	Length
EBU Prolog	STA	Start	1 byte
	ADD	Address	2 bytes
	SQC	Sequence Counter	1 byte
	MFL	Message Field Length	1 byte
EBU Message	MSG	Message	0 to 255 bytes
	MEC	Message Element Code	1 byte
	MEL	Message Element Data Length	1 byte
	MEC1	Manufacturers command 1 + 2	2 bytes
	MEC2		
	IDSN	Data Set Number	1 byte
IPSN	Program Service Number	1 byte	
IMED	Message Element Data		
EBU Epilog	###	Cyclic Redundancy Check	2 bytes
	STP	Stop	1 byte

Fields and whole message elements shown in brackets are optional. They are used as required by the specific command. Message elements may be concatenated freely, subject to a maximum message field length of 255 bytes.

1.2 Entry

To enter the commands, a computer (eg PC) is connected to one of the serial interfaces and the transmission program is loaded.

1.3 Notation

The values and parameters are given line by line in the individual commands. In each case the EBU message proper is indicated, each line corresponding to an ASCII character. The values or ranges are given in hexadecimal.

De- scriptor	Values	Explanation
	MSB LSB	
MEC	2D	Message Element Code (2D)
MEL	00 to FF	Message Element Data Length
MEC1	00 to FF	Manufacturer's Command 1
MEC2	00 to FF	Manufacturer's Command 2
IDSN	00to09,FE,FF	Data Set Number
IPSN	00 to FF	Program Service Number
IMED	00 to FF	Message Element Data
⋮	⋮	(parameter)

The message description is made according to the above diagram.

The first column indicates the descriptor of the message which is detailed in the table.

Second column: Each element in the table represents one byte where the bits are numbered from 7 to 0 (from left to right). For transmission of a respective message each byte is represented by two HEX symbols of which the permitted range is indicated in the respective element.

The third column gives an information of the context of the table.

1.4 Output Format

Read commands to the device cause the return message to be displayed on the screen. The output format corresponds to the syntax required for entering the corresponding command in accordance with the Universal Encoder Communication Protocol.

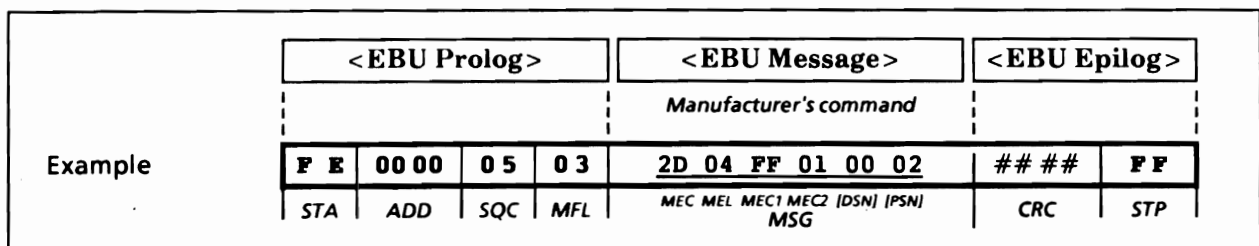

Fig. 1 Syntax

2 List of all Commands Defined

Set Commands

Function	Information	Command				Parameter
		EBU MEC	Manufacturer MEL MEC1 MEC2			
Set VRF information DK on/off	DK	2D	04	FE 00	03 hex FE 00 <2 Bytes> 00 00 = off 00 01 = on	Number of bytes (MEL) Command (MEC1 + 2) Parameter Parameter
Set Data mode Outgoing data RDS or Test		2D	04	FE 01	<2 Bytes> 00 00 = RDS data 00 01 = Test data	Parameter Parameter
Set Test data (13 bytes = 1 group = 104 bits)		2D	0F	FE 02	<13 bytes>	Parameter
Set Baudrate (for serial interfaces)		2D	07	FE 03	<5 Bytes> 1st byte: Interface no. 2nd byte: Baudrate 3rd byte: parity 4th byte: data bits 5th byte: stop bits	Parameter Parameter Parameter Parameter Parameter
Set Hardware handshake on/off (for all serial interfaces)		2D	04	FE 04	<2 Bytes> 00 00 = handshake off 00 01 = handshake on	Parameter Parameter
Set Message outputs A1 to A16 (MESSAGES / X12; relay K1 to K16)		2D	04	FE 05	<2 Bytes> 1st byte: output A1 to A8 (LSB = A1; MSB = A8) 2nd byte: output A9 to A16 (LSB = A9; MSB = A16)	
Set RDS/VRF phase 0°/90°		2D	04	FE 06	<2 Bytes> 00 00 = phase 0° 00 01 = phase 90°	Parameter Parameter

Note: Data set number DSN:
00 = Current data set
01 to 09 = data set 1 to 9
FE = All data sets except the current data set
FF = All data sets

Program service number PSN:
00 = Special PSN for main service of specified data set(s)
01 to FF = Specific service within data set(s),
p.e. EON information

RBDS: Radio broadcasting data system

**Operation Coders DMC01
Manufacturer's Specific Commands**

Request Commands

Function	Code				Parameter
	EBU	Manufacturer			
	MEC	MEL	MEC1	MEC2	
Request protocol type	2D	03	FF	40	1st byte: Interface number 00 = DTE 01 to 04 = DTE1 to DTE4 05 = DTE5 (with DMC01 only) <u>Return:</u> see EBU manufacturer's status command FD 00
Request serial number (production order number)	2D	02	FF	41	<u>Return:</u> see EBU manufacturer's test command F0 0A
Request Ident number (Stock number)	2D	02	FF	42	<u>Return:</u> see EBU manufacturer's test command F0 0B
Request coder type	2D	02	FF	43	<u>Return:</u> see EBU manufacturer's test command F0 0C
Request firmware version	2D	02	FF	44	<u>Return:</u> see EBU manufacturer's status command FD 01
Request physical address (manufacturer address)	2D	02	FF	45	<u>Return:</u> see EBU manufacturer's test command F0 05
Request Battery check	2D	02	FF	46	<u>Return:</u> see EBU manufacturer's test command FD 02

Status Commands

Function	Command				Return
	EBU	Manufacturer			
	MEC	MEL	MEC1	MEC2	
Status Protocol type	2D	04	FD	00	1st byte: Type of protocol 45 = EBU, 4C = Link, 54 = TNPP 2nd byte: RBDS 52 = on, 00 = off
Status Firmware version	2D	12	FD	01	<16 Byte>
Status Battery check	2D	04	FD	02	<2 Byte> 00 00 = defective 00 01 = o.k.

3 Message description

3.2 Set Commands

Message Name: Set VRF information DK

Message Element Code: 2D / FE 00

Function: Setting VRF information DK on/off

Format:

	MSB	LSB	
MEC	2D		EBU Code
MEL	04		
Man.MEC1	FE		Manufacturer's Code
Man.MEC2	00		
MED	00		
MED	00 to 01		00 = on 01 = off

Example <2D><04><FE><00><00><01>

Message Name: Set Data mode (RDS / Test)

Message Element Code: 2D / FE 01

Function: Setting data mode to RDS data or Test data;
 setting test data see command 2D / FE 02

Format:

	MSB	LSB	
MEC	2D		EBU Code
MEL	04		
Man.MEC1	FE		Manufacturer's Code
Man.MEC2	01		
MED	00		
MED	00 to 01		00 = RDS data 01 = Test datas (see command 2D / FE 02)

Example <2D><04><FE><01><00><01>

Operation Coder DMC01
Manufacturer's Specific Commands

Message Name: **Set Test data (1 RDS group)**

Message Element Code: **2D / FE 02**

Function: Setting of test data for one group with 104 bits (13 bytes)

Format:

	<table border="1" style="border-collapse: collapse; width: 100%;"> <tr> <td style="text-align: left; border: none;">MSB</td> <td style="text-align: right; border: none;">LSB</td> </tr> </table>	MSB	LSB	
MSB	LSB			
<i>MEC</i>	2D	<i>EBU Code</i>		
<i>MEL</i>	0E			
<i>Man.MEC1</i>	FE	<i>Manufacturer's Code</i>		
<i>Man.MEC2</i>	02			
<i>MED</i>	00 to FF	<i>Byte 1</i>		
	⋮			
<i>MED</i>	00 to FF	<i>Byte 13</i>		

Test datas (AA = 8 bits):
 0000 0000 = 00 hex
 0101 0101 = 55 hex
 1010 1010 = AA hex
 1111 1111 = FF hex

Example <2D><0E><FE><02><AA><AA> . . . <AA>

Message Name: **Set Serial interfaces - Baudrate**

Message Element Code: **2D / FE 03**

Function: Setting baudrate for serial interfaces DTE and DTE1 to DTE5 (DTE5 with DMC01 only)

Format:

	<table border="1" style="border-collapse: collapse; width: 100%;"> <tr> <td style="text-align: left; border: none;">MSB</td> <td style="text-align: right; border: none;">LSB</td> </tr> </table>	MSB	LSB														
MSB	LSB																
<i>MEC</i>	2D	<i>EBU Code</i>															
<i>MEL</i>	07																
<i>Man.MEC1</i>	FE	<i>Manufacturer's Code</i>															
<i>Man.MEC2</i>	03																
<i>MED</i>	00 to 05	<i>code for interface</i>	<table border="1" style="border-collapse: collapse; width: 100%;"> <thead> <tr> <th>Interface</th> <th>Code</th> </tr> </thead> <tbody> <tr><td>DTE</td><td>00</td></tr> <tr><td>DTE1</td><td>01</td></tr> <tr><td>DTE2</td><td>02</td></tr> <tr><td>DTE3</td><td>03</td></tr> <tr><td>DTE4</td><td>04</td></tr> <tr><td>DTE5</td><td>05</td></tr> </tbody> </table>	Interface	Code	DTE	00	DTE1	01	DTE2	02	DTE3	03	DTE4	04	DTE5	05
Interface	Code																
DTE	00																
DTE1	01																
DTE2	02																
DTE3	03																
DTE4	04																
DTE5	05																
<i>MED</i>	03 to C0	<i>code for baudrate</i>															
<i>MED</i>	'N', 'E', 'O'	<i>Parity bit</i>															
<i>MED</i>	07 to 08	<i>Number of data bits</i>															
<i>MED</i>	00/01	<i>Number of stop bits</i>															

Baudrate	Code
300 baud	03
600 baud	06
1200 baud	0C
2400 baud	18
4800 baud	30
9600 baud	60
19200 baud	C0

Parity bit	Code	Data bits	Code	Stop bits	Code
none	'N'	7	07	1	00
even	'E'	8	08	2	01
odd	'O'				

Example <2D><07><FE><03><01><60><'N'><08><01>

**Operation Coder DMC01
Manufacturer's Specific Commands**

Message Name: **Set Serial Interfaces - Hardware handshake (on/off)**

Message Element Code: **2D / FE 04**

Function: Hardware handshake on/off for all serial interfaces

Format:

	MSB	LSB	
<i>MEC</i>	2D		<i>EBU Code</i>
<i>MEL</i>	04		
<i>Man.MEC1</i>	FE		<i>Manufacturer's Code</i>
<i>Man.MEC2</i>	04		
<i>MED</i>	00		
<i>MED</i>	00 to 01		<i>00 = off 01 = on</i>

Example <2D> <03> <FE> <04> <00> (handshake off)

Message Name: **Set Parallel interface - Outputs**

Message Element Code: **2D / FE 05**

Function: Setting outputs A1 to A16 on the parallel interface
(MESSAGES / X12; relay K1 to K16)

Format:

	MSB	LSB	
<i>MEC</i>	2D		<i>EBU Code</i>
<i>MEL</i>	04		
<i>Man.MEC1</i>	FE		<i>Manufacturer's Code</i>
<i>Man.MEC2</i>	05		
<i>MED</i>	00 to FF		<i>output A1 to A8 (LSB = A1; MSB = A8)</i>
<i>MED</i>	00 to FF		<i>output A9 to A16 (LSB = A9; MSB = A16)</i>

Examples:		1 st	2 nd
hex	binary	byte	byte
01	000 0001	A1	A9
02	000 0010	A2	A10
04	000 0100	A3	A11
08	000 1000	A4	A12
10	0001 0000	A5	A13
20	0010 0000	A6	A14
40	0100 0000	A7	A15
80	1000 0000	A8	A16

Add hex values for setting more outputs with one command

Example <2D> <04> <FE> <01> <05> (Setting outputs A1 + A9 + A11)

**Operation Coder DMC01
Manufacturer's Specific Commands**

Message Name: **Set Phase RDS / VRF (0°/90°)**

Message Element Code: **2D / FE 06**

Function: **Setting phase between RDS and VRF signal**

Format:

	MSB	LSB	
<i>MEC</i>	2D		<i>EBU Code</i>
<i>MEL</i>	04		
<i>Man.MEC1</i>	FE		
<i>Man.MEC2</i>	06		<i>Manufacturer's Code</i>
<i>MED</i>	00		
<i>MED</i>	00 to 01		<i>00 = 0° 01 = 90°</i>

Example **<2D> <04> <FE> <06> <00> <01>**

3.2 Request Commands

Message Name: Request protocol type

Message Element Code: 2D / FF 40

Function: Request protocol type from the EEPROM
 see status protocol type (FD 00)

Format:

	MSB	LSB	
<i>MEC</i>	2D		<i>EBU Code</i>
<i>MEL</i>	03		
<i>Man.MEC1</i>	FF		<i>Manufacturer's Code</i>
<i>Man.MEC2</i>	40		
<i>MED</i>	00 to 05		<i>Code for Interface</i>

Interface	Code
DTE	00
DTE1	01
DTE2	02
DTE3	03
DTE4	04
DTE5	05

Example <2D> <03> <FF> <40> <01>

Readout *1st parameter* 45 = EBU protocol, 4C = Link protocol, 54 = TNPP protocol
 2nd parameter 00 = RBDS off, 52 = RBDS on

Message Name: Request serial number

Message Element Code: 2D / FF 41

Function: Request serial number from the EEPROM
 see test command F0 0A

Format:

	MSB	LSB	
<i>MEC</i>	2D		<i>EBU Code</i>
<i>MEL</i>	02		
<i>Man.MEC1</i>	FF		<i>Manufacturer's Code</i>
<i>Man.MEC2</i>	41		

Example <2D> <02> <FF> <41>

**Operation Coder DMC01
Manufacturer's Specific Commands**

Message Name: Request Ident number

Message Element Code: 2D / FF 42

Function: Request ident number (stock number) from the EEPROM
see test command F0 0B

Format:

	MSB	LSB	
<i>MEC</i>	2D		<i>EBU Code</i>
<i>MEL</i>	02		
<i>Man.MEC1</i>	FF		<i>Manufacturer's Code</i>
<i>Man.MEC2</i>	42		

Example <2D> <02> <FF> <42>

Message Name: Request Coder type

Message Element Code: 2D / FF 43

Function: Request coder type from the EEPROM
see test command F0 0C

Format:

	MSB	LSB	
<i>MEC</i>	2D		<i>EBU Code</i>
<i>MEL</i>	02		
<i>Man.MEC1</i>	FF		<i>Manufacturer's Code</i>
<i>Man.MEC2</i>	43		

Example <2D> <02> <FF> <43>

**Operation Coder DMC01
Manufacturer's Specific Commands**

Message Name: Request Firmware version

Message Element Code: 2D / FF 44

Function: Request Firmware version from the EEPROM
see status firmware version command FD 01

Format:

	MSB	LSB	
<i>MEC</i>	2D		<i>EBU Code</i>
<i>MEL</i>	02		
<i>Man.MEC1</i>	FF		<i>Manufacturer's Code</i>
<i>Man.MEC2</i>	44		

Example <2D> <02> <FF> <44>

Message Name: Request Physical address

Message Element Code: 2D / FF 45

Function: Request Physical (manufacturer) address from the EEPROM
see request command F0 05

Format:

	MSB	LSB	
<i>MEC</i>	2D		<i>EBU Code</i>
<i>MEL</i>	02		
<i>Man.MEC1</i>	FF		<i>Manufacturer's Code</i>
<i>Man.MEC2</i>	45		

Example <2D> <02> <FF> <45>

**Operation Coder DMC01
Manufacturer's Specific Commands**

Message Name: Request Battery check

Message Element Code: 2D / FF 46

Function: Request Battery check
see status battery check FD 02

Format:

	MSB	LSB		
MEC	2D		EBU Code	
MEL	02		00 01	
Man.MEC1	FF		Manufacturer's Code	00 01 = o.k.
Man.MEC2	46			00 00 = defective

Example <2D><02><FF><46> <00><01>

3.3 Status Commands

Message Name: **Status Protocol type**

Format:

	MSB	LSB	
<i>MEC</i>	2D		<i>EBU Code</i>
<i>MEL</i>	04		
<i>Man.MEC1</i>	FD		<i>Manufacturer's Code</i>
<i>Man.MEC2</i>	00		

1st Byte:
 45 = EBU
 4C = Link
 54 = TNPP
2nd Byte:
 52 = RBDS on
 00 = RBDS off

Example <2D><04><FD><00> <45><00>

Message Name: **Status Firmware Version**

Format:

	MSB	LSB	
<i>MEC</i>	2D		<i>EBU Code</i>
<i>MEL</i>	12		
<i>Man.MEC1</i>	FD		<i>Manufacturer's Code</i>
<i>Man.MEC2</i>	01		

Information <16 bytes>

Example <2D><12><FD><01> <16 bytes>

Message Name: **Status Battery check**

Format:

	MSB	LSB	
<i>MEC</i>	2D		<i>EBU Code</i>
<i>MEL</i>	04		
<i>Man.MEC1</i>	FD		<i>Manufacturer's Code</i>
<i>Man.MEC2</i>	02		

00 00 = Battery defective
 00 01 = Battery o.k.

Example <2D><04><FD><02> <00><01>

4 Test Commands

Note:

These commands are for service only

Function	Command				Parameter
	EBU MEC	Manufacturer MEL	MEC1	MEC2	
Set test command enabled only for one test set command or one test request command	2D	04	F0 00		1 st and 2 nd byte: Parameter 00 01 = set for one test command 00 00 = cancel test mode
Request parallel remote control inputs E1 to E16 (REMOTE CONTROL / X11)	2D	02	F0 03		<u>Return:</u> see EBU Manufacturer's command F0 04
Status parallel remote control inputs E1 to E16 (REMOTE CONTROL / X11)	2D	04	F0 04		<2 bytes> Value
Set physical address (manufacturer's address)	2D	04	F0 05		<2 bytes> Address
Set start update Flash memory (Update firmware)	2D	04	F0 06		1 st and 2 nd byte: Parameter 00 01 Start flashup
Set Cold start	2D	04	F0 07		1 st and 2 nd byte: Parameter 00 01 Cold start
Set Warm start	2D	04	F0 08		1 st and 2 nd byte: Parameter 00 01 Warm start
Set Serial number *) (production order number)	2D	12	F0 0A		<16 bytes> Information
Set Ident number *) (Stock number)	2D	12	F0 0B		<16 bytes> Information
Set Type of coder *)	2D	12	F0 0C		<16 bytes> Information
Set Watchdog on/off	2D	04	F0 0D		1 st and 2 nd byte: Parameter 00 00 = off 00 01 = on

*) Command not available for user!





ROHDE & SCHWARZ

Communications
Division

Operating Manual

Software

Link Protokoll for Decoder

RDS CODEC

DMC01 and DMC01C

RDS DECODER

DMDC03 and DMDC05

Printed in the Federal
Republic of Germany

CONTENTS

1	Introduction	
1.1	Entry	5
1.2	Output Buffer Capacity	5
1.3	Syntax	5
Fig. 1	Syntax overview	5
1.4	Checksum	6
1.5	Transmission Sequence	6
Fig. 2	Transmission sequence	6
1.6	Acknowledgement	6
1.7	Return Messages	6
2	List of all Commands Defined	7
3	Output Formats	
	Output of decoder identification DI	8
	Output of music/speech identification MS	8
	Output of in-house application IH	8
	Output of program identification PI	8
	Output of program-item number PIN	8
	Output of program service name PS	8
	Output of program type PTY	8
	Output of traffic-announcement identification TA	8
	Output of transparent data channel TDC	9
	Output of alternative frequencies AF	9
	Output of radio text RT	9
	Output of traffic-program identification TP	9
	Output of program service name of other networks PS(ON)	9
	Output of alternative frequencies of other networks AF(ON)	9
	Extendet generic indicator of other networks EG	9
	Output of linkage actuator of other networks LA	9
	Output of linkage set number of other networks LN	9
	Output of program type of other networks PTY(ON)	9
	Output of traffic-program identification of other networks TP(ON)	10
	Traffic-announcement identification of other networks TA(ON)	10
	Output of program-item number of other networks PIN(ON)	10
	Output of in-house application of other networks IH(ON)	10
	Output of user code 10 of other networks AC10(ON)	10
	Output of user code 11 of other networks AC11(ON)	10
	Output of user code 12 of other networks AC12(ON)	10
	Output of user code 13 of other networks AC13(ON)	10
	Output of user code of other networks AC(ON)	10
4	Output Control	11
5	Link protocol	
Table 1:	Commands for Decoder Link interface	12

The output of RDS data in abbreviated form (no dialog mode) is possible on an RDS coder or a PC. Commands and data are written and transmitted in ASCII.

1 Introduction

The link protocol allows entries via the serial interfaces using command sets (no dialog mode), these commands causing the decoder to output the corresponding data.

A commercial PC provided with a transmission program (with checksum generation) is sufficient for this purpose. If a faulty command is entered, the device issues a return message.

1.1 Entry

When the interface is in the link mode, commands may be entered. The hardware handshake is used; use of an XON/XOFF protocol is not possible.

If entry is not possible, one of the following measures may be required.

Changeover to the link mode

The interface may be in the terminal mode and not in the link mode. For changing over use the corresponding command in the terminal protocol.

Changing the data protocol

The transmission rate and format of the interface and the terminal must be identical.

Example: 9600, N, 8, 1 means
9600 baud, no parity, 8 data bits, 1 stop bit.

This setting can be made on the device.

1.2 Output Buffer Capacity

If data are output from the DMDC on a link interface, it is possible that the output capacity of the RS-232-C interface will not be sufficient.

The output capacity of the RS-232-C interface is determined by the following conditions:

- ▶ Selected baud rate
- ▶ Effective baud rate determined by hardware handshake

Output buffers are provided in the DMDC for each type of information intended for the link interfaces. If these output buffers overflow, the information is discarded.

1.3 Syntax

Each command consists of a specific letter, a parameter section and the data.

To facilitate the detection of data transmission errors, each command is preceded by a two-digit checksum. Each command is terminated by the ASCII character <ETX>. Composite outputs, ie partial lists of alternative frequencies, are combined by the ASCII character <RS> and terminated by the ASCII character <ETX>. After an command has been output, the DMDC waits for an acknowledgement which is given with <ACK> or <NAK>.

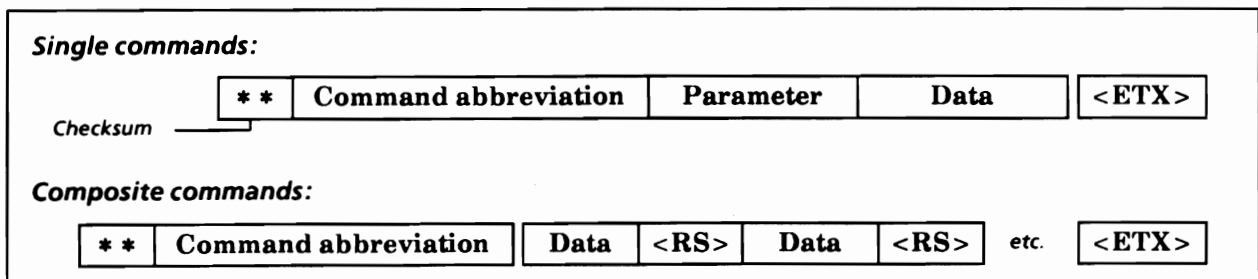

Fig. 1 Syntax overview

The checksum is followed by an ASCII character to specify the command and by a further ASCII character to indicate the data set to which the subsequent data refer. If X is entered, all data sets are addressed. A0 addresses the current data set.

1.4 Checksum

The checksum P in the form of two bytes, P1 and P2, precedes every command or partial command. To calculate the checksum, first all decimal equivalents of the ASCII characters including the terminator are summed up and a division modulo 65536 is performed. For transmission, the result P is subdivided into the two bytes P1 and P2. P1 and P2 may amount to 255 at the maximum. The following equations apply:

$$P = \sum_{n=1}^K \text{decimal equivalents of ASCII characters} \pmod{65536}$$

$$P = 256 \times P1 + P2$$

$$P1 = \text{Int}(P/256)$$

$$P2 = P \pmod{256}$$

1.5 Transmission Sequence

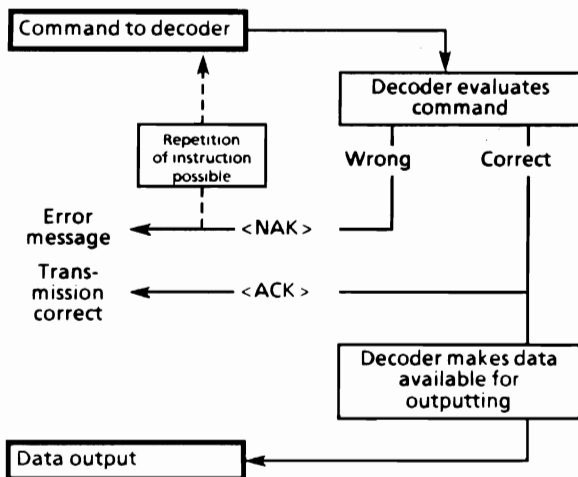

Fig. 2 Transmission sequence

1.6 Acknowledgement

Devices connected to the equipment may detect transmission errors by evaluating the checksum. An acknowledgement shows that an output has been accepted.

For error-free commands, an <ACK> is sent back, otherwise <NAK> is transmitted.

After each command the DMDC waits for an acknowledgement.

If <ACK> is sent, the command is considered correct and output. After receiving <NAK>, the output of the command is repeated. The number of repetitions can be set by a parameter (see SETUP menu). If no acknowledgement is received during an adjustable timeout, the output is considered to be accepted.

1.7 Return Messages

In addition to the acknowledgement of commands, the decoder waits for return messages. This wait function which can be disabled signals to the decoder that the IH, RT and TDC information sent is complete. With the wait function enabled, the decoder sends the next command only after a return message has been received for the previous command (IH, RT or TDC).

The return messages always start with a specific letter. The IH and TDC return messages also include the channel number of the information transmitted.

Examples:

- ▶ Command IH information channel 27 sent, return message p1B required
- ▶ Command radiotext sent, return message f required
- ▶ Command TDC information channel 03 sent, return message o03 required

If, with the return function enabled, no message is received within the adjustable timeout (see SETUP menu), the output concerned is repeated. It is possible to set the number of repetitions (see SETUP menu).

2 List of all Commands Defined

The checksum is followed by the command-specific letter (IK) which indicates the type of information sent. See table below.

Symbol. "IK"	Informations	Function
0z	8B	Group 8B
1z	1A (block 3)	Group 1A, block 3
3z	3A	Group 3A
4z	4A	Group 4A
5z	5A	TDC (Group 5A)
5z	5B	Group 5B
5z	TDC	Transparent data channel
8z	8A	TMC (Group 8A)
9z	9A	EWS (Group 9A)
Az	10A	Group 10A
Bz	11A	Group 11A
Cz	12A	Group 12A
d	PI	Program identification
Dz	13A	Group 13A
e	PS	Program serving name
EA	AC10(ON)	EON - User code 10
EB	AC11(ON)	EON - User code 11
EC	AC12(ON)	EON - User code 12
Ed	EG(ON)	EON - extended other networks
ED	AC13(ON)	EON - User code 13
Ee	PI(ON)	EON - Program identification
Ee	PS(ON)	EON - Program serving name
Ef	AF(ON)	EON - alternative frequencies A
Eg	AF(ON)	EON - alternative frequencies B
EG	AC(ON)	EON - User code
Eh	TP(ON)	EON - Traffic program identification

Symbol. "IK"	Information	Function
Ei	TA(ON)	EON - Traffic announcement ident.
Ek	PTY(ON)	EON - Program type
Em	PIN(ON)	EON - Program item number
Ep	IH(ON)	EON - Inhouse information
Eq	LN(ON)	EON - Linkage number
Er	LA(ON)	EON - Linkage actuator
f	RT	Radio text
Fz	15A	Group 15A
g	AF	Alternative frequencies
h	TP	Traffic program identification
H _z	1B (block 2)	Group 1B, block 2
i	TA	Traffic announcement identification
j	MS	Music/speech
Jz	3B	Group 3B
k	PTY	Program type
Kz	4B	Group 4B
l	DI	Decoder identification
m	PIN	Program item number
n	CT	Clock/Time
Nz	7B	Group 7B
p	IH	Inhouse information
Pz	9B	Group 9B
Qz	10B	Group 10B
Rz	11B	Group 11B
Sz	12B	Group 12B
Tz	13B	Group 13B

3 Output Formats

Below a brief output description is given for each type of information. The following symbols and abbreviations are used:

- ▶ **
Checksum consisting of two characters
- ▶ <DS>
Data set to which the command is addressed. The data set address consists of an ASCII character (0, 1, ... 8, X).
0 transmitted data set
1 to 8 Data set number 1 to 8
X all data sets
- ▶ A
Any ASCII character to specify the data output
- ▶ <ETX>
ASCII end-of-text character
- ▶ <RS>
ASCII record separator

Output of decoder identification DI

Syntax:

** l <DS> A <ETX>
A = 0, 1, 2, 3, 4, 5, 6, 7, 8, 9, A, B, C, D, E, F

Example:

** l X1

Output of music/speech identification MS

** j <DS> A <ETX>
A = 0, 1

Example:

** j X1

Output of in-house application IH

Syntax:

** p <DS> 011AAAAAAAAAA <ETX>
AAAAAAAAAA =
channel number (2 hex characters)
followed by data (8 hex characters)

Example:

** p X0211E02468ACE

Output of program identification PI

Syntax:

** d <DS> AAAA <ETX>
AAAA = PI code

Example:

** d 3D781

Output of program-item number PIN

Syntax:

** m <DS> AAAA <ETX>
AAAA = hex characters coded to EBU

Example:

** m X715E

Output of program service name PS

Syntax:

** e <DS> AAAAAAAAAA <ETX>
AAAAAAAAAA = PS code

Example:

** e 3NDR 1 SH

Output of program type PTY

Syntax:

** k <DS> AA <ETX>
AA = EBU code for PTY in hex notation

Example:

** k X01

Output of traffic-announcement identification TA

Syntax:

** i <DS> A <ETX>
A = 0 or 1

Example:

** i X1 (TA on)

Operation Decoder DMC01 - DMDC
Link Protocol

Output of transparent data channel TDC

Syntax:

** o 1AAAAAAAAA <ETX>
AAAAAAAAA =
channel number (2 hex characters)
followed by data (8 hex characters)

Example:

** 5z11C01FFFF0000

Output of alternative frequencies AF

Syntax:

** g<DS>AA<ETX>
AA = EBU code for PTY (2 hex characters)

Example:

** g303E32C016C'
** E56C012C3958'
** E7017B58BC2C5954

Output of radio text RT

Syntax:

** f<DS>AAAA AA...<ETX>
AAAA = Data
AA... = Text (2... 64 characters)

Example:

** f X0111<UKW/FM-ARD-Radiotext>

Output of traffic-program identification TP

Syntax:

** h<DS> A <ETX>
A = 0 or 1

Example:

** h31 (TP on)

**Output of program service name
of other networks PS(ON)**

Syntax:

** Ee<DS>AAAA<ETX>
A = 0 or 1

Example:

** Ee3D681NDR 1 HH

**Output of alternative frequencies
of other networks AF(ON)**

Syntax:

** Ef<DS>AAAA AA...<ETX>
AAAA AA... = Data

Example:

** Ef2D681E46E626775 (input AF)
** Ef3D681 (delete AF for D681)

**Extendet generic indicator
of other networks EG**

** Ed<DS>A<ETX>

A = 0 (not extended) or 1 (extended)

Example:

** EdXD6810

**Output of linkage actuator
of other networks LA**

** Er<DS>AAAA A<ETX>

AAAA A = Data

Example:

** ErXD6811

**Output of linkage set number
of other networks LN**

** Eq<DS>A<ETX>

A = 0 (off) oder 1 (on)

Example:

** EqXD68103C1

**Output of program type
of other networks PTY(ON)**

** Ek<DS>AAAA AA<ETX>

AAAA AA = Data

Example:

** EkXD68101

Operation Decoder DMC01 - DMDC
Link Protocol

**Output of traffic-program identification
of other networks TP(ON)**

** Eh<DS>AAAA A<ETX>
AAAA A = Data

Example:
** Eh

**Traffic-announcement identification
of other networks TA(ON)**

** Ei<DS>AAAA A<ETX>
AAAA A = Data

Example:
** Ei

**Output of program-item number
of other networks PIN(ON)**

** Em<DS>AAAA AAAA<ETX>
AAAA AAAA = Data

Example:
** EmXD681AF01

**Output of in-house application
of other networks IH(ON)**

** Ep<DS>AAAA AAAA<ETX>
AAAA AAAA = Data

Example:
** EpXD6811AF01
** EpXD6811FFFF(*delete all EON for D681*)

**Output of user code 10
of other networks AC10(ON)**

** EA<DS>AAAA AAAA<ETX>
AAAA AAAA = Data

Example:
** EAXD68110000

**Output of user code 11
of other networks AC11(ON)**

** EB<DS>AAAA AAAA<ETX>
AAAA AAAA = Data

Example:
** EBXD68110000

**Output of user code 12
of other networks AC12(ON)**

** EC<DS>AAAA A<ETX>
AAAA A = Data

Example:
** ECXD6810

**Output of user code 13
of other networks AC13(ON)**

** ED<DS>AAAA AAAA<ETX>
AAAA AAAA = Data

Example:
** EDXD681000

**Output of user code
of other networks AC(ON)**

** EG<DS>AAAA A<ETX>
AAAA A = Data

Example:
** EGXD6817

4 Output Control

Information items are output on the interfaces only after having been enabled for the interface concerned. This is possible either via the front-panel menu or via the terminal interface.

The enabled information items are output only under the following conditions:

- ▶ after the first reception of the information
- ▶ after elimination of all faults
- ▶ after each information change, at the latest 20 ms after the information is complete
- ▶ cyclically as indicated below for the individual information items
- ▶ after switching over the data set address of the interface or data link

If under these conditions several RDS information items have to be output, the items are output according to a defined set of priorities.

Priority of output and interval for cyclical output:

- ▶ AF 5 minutes
- ▶ DI 10 seconds
- ▶ MS 10 seconds
- ▶ PI 10 seconds
- ▶ PIN 10 seconds
- ▶ PS 10 seconds
- ▶ PTY 10 seconds
- ▶ TA 10 seconds
- ▶ TP 10 seconds

- ▶ AC10 150 seconds
- ▶ AC11 150 seconds
- ▶ AC12 150 seconds
- ▶ AC13 150 seconds
- ▶ ACON 150 seconds
- ▶ AFON 5 minutes
- ▶ EGON 150 seconds
- ▶ LAON 150 Seconds
- ▶ LNON 150 seconds
- ▶ PTYON 150 seconds
- ▶ TAON 150 seconds
- ▶ TPON 150 seconds
- ▶ PINON 150 seconds
- ▶ PSON 150 seconds

The individual information items are output consecutively with a spacing of 10 s. A maximum of 20 information items from other networks can be stored for each EON information.

The IH and TDC information items are output for single transmission after complete reception of the corresponding group. The RT information is output for single transmission after complete reception of the radiotext marked by an end-of-text character.

After a brief AC supply failure which does not generate a fault message, commenced data outputs are started again on power up.

The AF lists received are completely output if an AF list has been received twice.

After a change of the TA information started outputs are aborted, marked by the <CAN> character. Then the changed TA information is output.

The interfaces are switched off during a block error of tolerance class A (BLERR TOLA).

After IH(ON) with the contents \$FFFF has been received for the first time, the information memories for the associated PI(ON) are cleared. As soon as the IH(ON) information output is enabled, the information \$FFFF with the associated PI(ON) is issued.

If a user code with already stored EON information is not received within 3 minutes, the information stored in the information memory is cleared and, in the enable mode, the command for clearing the information is issued.

5 Link protocol

The link protocol complies with specifications No. 5/3.8, part 1 (basic unit), of the broadcasting corporations under public law in the Federal Republic of Germany.

Table 1: Commands for Decoder Link interface

Informations	Commands				Explanation	Example
	Symbol	DS	Extn	Range		
DS		1A		DS: 0 - 8 / X	Transfer address for data-record-dependent information	
PI	d	1A	4A	\$1001-FFFF		**d3D781 <ETX>
PS	e	1A	8A	EN 50 067	RDS standard	**e3NDR 1 SH <ETX>
AF	g	1A	2A + n * (m * 2A)	\$00-40 \$00 to FF	Number of AF lists n (n = 0: no AF list) (m = number of AF, 2-32) AF codes corr. to DIN EN 50 067	**g303E32C016C <RS> **E56C012C3958 <RS> **E7017B58BC25954 <ETX>
TP	h	1A	1A	0 or 1	0 = off, 1 = on	**h31 <ETX>
TA	i	1A	1A	0 or 1	0 = off, 1 = on	**iX1 <ETX>
DI	l	1A	1A	\$0 to F	Decoder 0 to 15	**lX1 <ETX>
MS	j	1A	1A	0 or 1	0 = Speech, 1 = Music	**jX1 <ETX>
PTY	k	1A	2A	\$00 to 1F	Program type: 0 to 31	**kX01 <ETX>
PIN	m	1A	4A	\$0000-FE00	14.day 5.30	**mX715E <ETX>
RT	f	1A	4A + (2A to 64A)	\$0111	Frequency of emission : 01 = single shot Text	**fX0111 < FM - ARD - Radiotext > <ETX>
TDC	5z	--			Data transmission	
IH	p	1A	2A + 1A + 2A + 4A/8A	\$01 \$1 \$00 to 1F \$0 to F	Number of IH messages n How often to transmit (1 = once) Channel number 0 to 31 IH information	**pX0211E02468ACE <ETX> If group 6B is received, only 4 characters are transferred
PI(ON)			PI INFO	\$1001-FFFF	Leave out INFO when erasing	**Ee3D681 <ETX> PS(ON) in DS3 for D681
PS(ON)	Ee	1A	4A + 8A			**Ee3D681NDR 1 HH <ETX>
AF(ON)	Ef	1A	4A + m*2A		AF version A m = number of AF codes, 2 to 32	**Ef2D681E46E626775 <ETX> **EfXD681 <ETX> (deletes AF)
AF(ON)	Eg	1A	4A + [2A + n*(2A + [1 to 4*2A] [+ M + 2A]]	\$01 to 40 \$00 to FF \$00 to FF \$00 to FF	AF version B n = Number of AF lists AF: Tuned frequencies TN up to 4 FM codes and/or 1 AM code (with "M") Input of new AF deletes all old AF for other program in the actual data set	**Eg3D681 <ETX> (deletes AF) **Eg2D68103146E62 <RS> **09626E <RS> **4375 <ETX> **Eg2D68103146E6275M41 <RS> **09626EM41 <RS> **4375M41 <ETX>
EG(ON)	Ed	1A	4A + 1A	0 or 1	0 = not expanded, 1 = expanded AC = 12: bit m ₁₄ 1)	**EdXD6810 <ETX>
LA(ON)	Er	1A	4A + 1A	0 or 1	0 = off, 1 = on AC = 12: bit m ₁₅ 1)	**ErXD6811 <ETX>
LN(ON)	Eq	1A	4A + 4A	\$0000-1FFF	\$0AAA = national, \$1AAA = international AC = 12: bits m ₁₂ to m ₀₀ 1)	**EqXD68103C1 <ETX>
PTY(ON)	Ek	1A	4A + 2A	\$00 to 1F	Program type 0 to 31 AC = 13: bits m ₁₅ to m ₁₁ 1)	**EkXD68101 <ETX>
TP(ON)	Eh	1A	4A + 1A	0 or 1		**EhXD6811 <ETX>
TA(ON)	Ei	1A	4A + 1A	0 or 1		**EiXD6810 <ETX>
PIN(ON)	Em	1A	4A + 4A	\$0000-1FE00	day 14, hour 5.30	**EmXD681715E <ETX>
IH(ON)	Ep	1A	4A + 4A	\$0000-FFFF	INFO = \$FFFF deletes all EON for this PI code	**EpXD681AF01 <ETX> **EpXD681FFFF <ETX> delete all EON for D681
AC10(ON)	EA	1A	4A + 4A	\$0000 to 1FFF	AC = 10: 16 free bits	**EAXD6810000 <ETX>
AC11(ON)	EB	1A	4A + 4A	\$0000 to 1FFF	AC = 11: 16 free bits	**EBXD6810000 <ETX>
AC12(ON)	EC	1A	4A + 1A	0 or 1	AC = 12: bit m ₁₃ 1)	**ECXD6810 <ETX>
AC13(ON)	ED	1A	4A + 3A	\$000 to 3FF	AC = 13: bits m ₁₀ - m ₀₁ 1)	**EDXD681000 <ETX>
AC(ON)	EG	1A	4A + 1A	\$0 to 7	3 free bits in group 14B, block 2	**EGXD6817 <ETX>

For explanations, refer to preceding page.

**Operation Decoder DMC01 - DMDC
Link Protocol**

Table 1 Cont

Group	Sym- bol	Commands			Explanation	Example
		DS	Extn	Range		
1A (Block 3)	1z	1A	1A + 1A + 3A	\$0 to F \$0 to 7 \$000 to FFF	Priority: P = 15 transmit once AC: block 3, bits m ₁₄ to m ₁₂ 1) Inform.: block 3, bits m ₁₁ to m ₀₀ 1)	**1zX56123 <ETX>
1B (Block 2)	Hz	--	1A + 2A + 2A	\$1 \$01 \$00 to FF	How often to transmit: 1 Number n of information items: 1 Inform.: block 2, bits m ₀₄ to m ₀₀ 1)	**Hz10106 <ETX>
3A	3z	--	1A + 2A + (10A/6A)	\$1 \$01 \$0000000000 to 1FFFFFFF	How often to transmit: 1 Number n of information items: 1 Info for one group in version B \$000000 to 1FFFFF	**3zD1010123456789 <ETX>
3B	Jz					
4A	4z	--	1A + 2A + n*A	\$1 \$01 \$0 to 7	How often to transmit: 1 Length n of Information: 1 3 free bits in block 2	**4z1017 <ETX>
4B	Kz	--	1A + 2A + 6A	\$1 \$01 \$000000 to 1FFFFF	How often to transmit: 1 Number n of information items: 1 Information 2/4 characters in block 2/4	**Kz101123456 <ETX>
5A 5B (TDC)	5z	--	1A + 2A + 2A + (8A/4A)	\$1 \$01 to 1F \$01 \$00000000 to FFFFFFFF	How often to transmit: 1 Channel number 0 to 31 Number n of information items: 1 Information 4 characters in block 3 and 4 version B \$0000 to FFFF (block 4)	**5z11C01FFFF0000 <ETX> If group 5B is received, only 4 characters are transferred
7B	Nz	--	1A + 2A + 6A	\$1 \$01 \$000000 to 1FFFFF	How often to transmit: 1 Number n of information items: 1 Info for one group 2/4 characters in block 2/4	**Nz101123456 <ETX>
8A 8B	8z 0z	--	1A + 2A + (10A/6A)	\$1 \$01 \$0000000000 to 1FFFFFFF	How often to transmit: 1 Number n of information items: 1 Info for one group in version B \$000000 to 1FFFFF	**0z101012345 <ETX>
9A 9B (EWS)	9z Pz	--	1A + 2A + (10A/6A)	\$1 \$01 \$0000000000 to 1FFFFFFF	How often to transmit: 1 Number n of information items: 1 Info for one group in version B \$000000 to 1FFFFF	**9zF1010123456789 <ETX> EWS in group 9A only
10A 10B	Az Qz	--	1A + 2A + (10A/6A)	\$1 \$01 \$0000000000 to 1FFFFFFF	How often to transmit: 1 Number n of information items: 1 Info for one group in version B \$000000 to 1FFFFF	**Az1010123456789 <ETX>
11A 11B	Bz Rz	--	1A + 2A + (10A/6A)	\$1 \$01 \$0000000000 to 1FFFFFFF	How often to transmit: 1 Number n of information items: 1 Info for one group in version B \$000000 to 1FFFFF	**Bz1010123456789 <ETX>
12A 12B	Cz Sz	--	1A + 2A + (10A/6A)	\$1 \$01 \$0000000000 to 1FFFFFFF	How often to transmit: 1 Number n of information items: 1 Info for one group in version B \$000000 to 1FFFFF	**Sz101012345 <ETX>
13A 13B	Dz Tz	--	1A + 2A + (10A/6A)	\$1 \$01 \$0000000000 to 1FFFFFFF	How often to transmit: 1 Number n of information items: 1 Info for one group in version B \$000000 to 1FFFFF	**Dz1010123456789 <ETX>
15A	Fz	--	1A + 2A + 10A	\$1 \$01 \$0000000000 to 1FFFFFFF	How often to transmit: 1 Number n of information items: 1 Info for one group	**Fz1010123456789 <ETX>

Explanation:

IK	Information	[]	optional	**	Check sum to next RS or ETX
DS	Data set	AC	User code	\$	HEX character (ASCII)
A	8-bit character	EG	<i>Extended generic indicator</i>	/	with commands and ranges: or
+	Parts of the commands are joined without separator	LA	<i>Linkage actuator</i>	m, n	The "contents" column is not part of the commands, but are factors
		LN	<i>Linkage number</i>		

Note: 1) Bitposition see RDS standard





ROHDE & SCHWARZ

Communications
Division

Operating Manual

Software

Terminal Protocol for Decoder

RDS CODEC

DMC01 and DMC01C

RDS DECODER

DMDC03 and DMDC05

Printed in the Federal
Republic of Germany

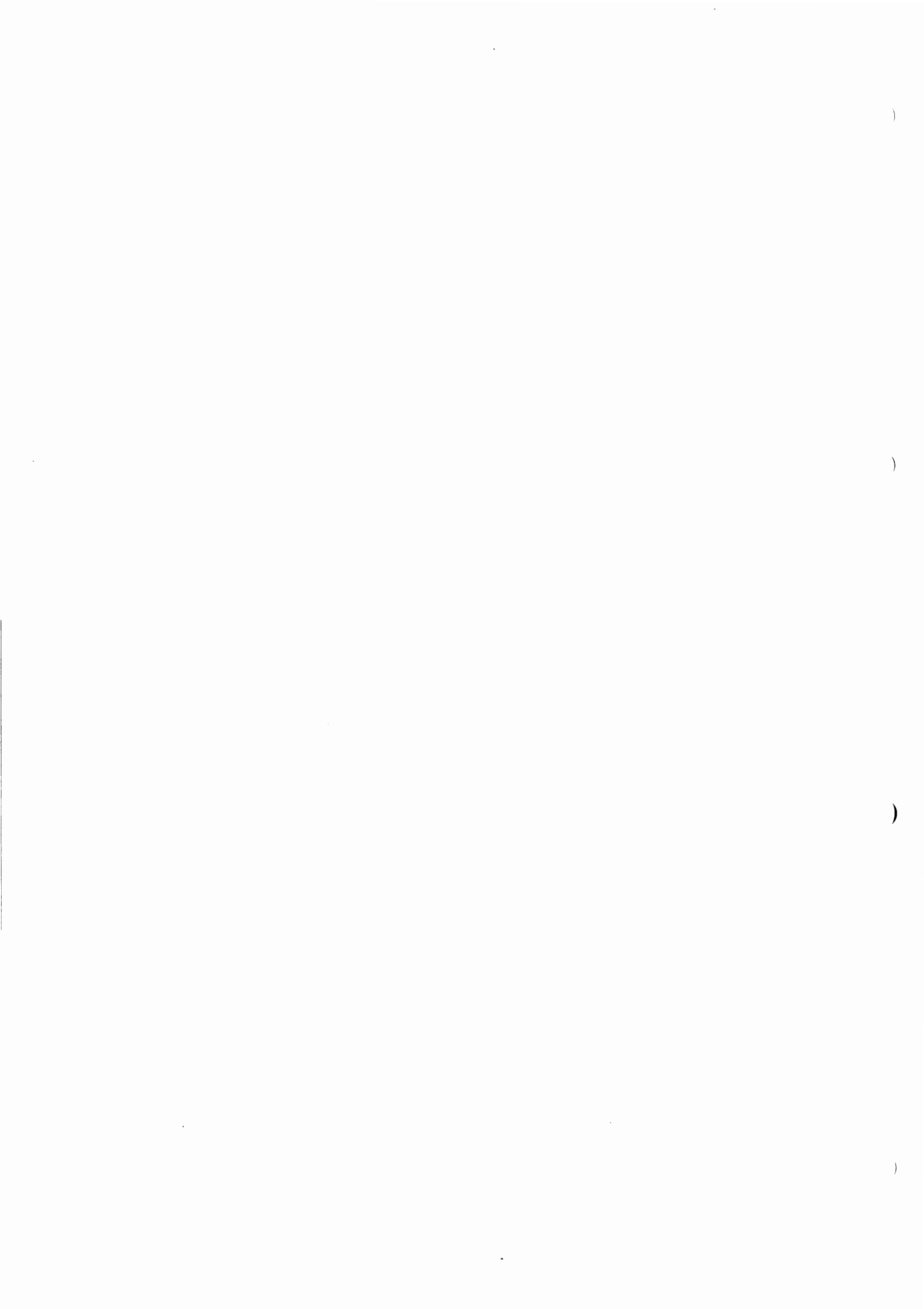

CONTENTS

1	Introduction	
1.1	Preliminary Remarks	5
1.2	Entry	5
1.3	Help Function	5
Fig. 1	Syntax	5
1.4	Characters	6
	Delimiters	6
	Terminators	6
	Special characters	6
	Termination of continuous output	6
	Termination of outputs and inputs	6
	Switch-on test	6
1.5	Output Buffer Capacity	6
1.6	Data Memory	6
2	List of all Commands Defined	7
3	Message description	
	Command and default syntax	9
	AC Command	9
	AC10 Command	9
	AC11 Command	9
	AC12 Command	9
	AC13 Command	9
	ACK Command	10
	ACON Command	10
	AF Command	10
	AFL Command	10
	AFON Command	11
	AI Command	11
	AION Command	11
	BL Command	11
	CT Command	11
	DECODE Command	12
	DI Command	12
	DISP Command	12
	DS Command	12
	GR Command	13
	HELP Command	13
	IH Command	13
	IHON Command	14
	INFO Command	14
	COUPLE Command	14
	LA Command	14
	LAON Command	14
	LN Command	15
	MENU Command	15
	MODE Command	15
	MONITOR Command	15
	MS Command	15
	MVAL Command	15
	MVP Command	16

**Operation Decoder DMC01 - DMDC
Terminal Protokol**

POWER Command	16
LVL Command	16
LVLC Command	16
PAGING Command	16
PH Command	17
PHC Command	17
PI Command	17
PIN Command	17
PINON Command	18
PION Command	18
PS Command	18
PTY Command	18
PTYON Command	18
SOURCE Command	18
SRCE,A/SRCE,B Command	19
R-V Command	19
R-VC Command	19
RT Command	19
SET Command	20
SHOW Command	20
INHIB Command	20
FAULT Command	20
BLERR Command	20
SY Command	21
TA Command	21
TAON Command	21
TDC Command	21
TEST Command	22
TP Command	22
TPON Command	22
Command for Output of Unformatted Block Contents	23
4 Terminal Protokol	24
Table 1: Input via Decoder Terminal Interface	24
Table 2: Settings via Decoder TTerminal Interface	26

1 Introduction

1.1 Preliminary Remarks

Inputs in the dialog mode are possible via the RS-232-C interfaces. A commercial ASCII terminal is sufficient for this purpose. It is also possible to connect a PC which has an integrated terminal emulation program. If an command is entered in dialog mode, the DMC replies with the desired information.

If parameters are indicated directly behind the command word, the query is skipped. When the inputs are incomplete and erroneous, they are ignored and the relevant error messages are output.

Commands are terminated with <CR>.

Each character entered is output as an echo character. The input buffer is checked and evaluated after entering a delimiter.

1.2 Entry

When the interface is in the terminal mode, the device displays the following prompt after one of the keys has been pressed:

DMC01> or **DMDCxx>**

Entering **DECODER** and <CR> changes over to the decoder terminal protocol displaying the prompt

DECODER>

Next, commands can be entered.

If entry is not possible, one of the following measures may be required.

Changeover to the terminal mode

The interface may be in the link mode and not in the terminal mode. For changing over use the corresponding command in the link protocol.

Changing the data protocol

The transmission rate and format of the interface and the terminal must be identical.

Example: 9600, N, 8, 1 means

9600 baud, no parity, 8 data bits, 1 stop bit.

1.3 Help Function

The HELP command permits recalling of a list of commands and parameters which are valid for the terminal interface. The commands cover several pages on the screen.

Entering a parameter allows the individual pages to be called up (see HELP command).

Syntax of a single command

Separated by commas, the parameters are added to the command. Termination by <CR>.

Command , parameter 1 , parameter 2 , ... , parameter n <CR>

Syntax of an command string

Separated by semicolons, several commands follow each other, however, without <CR>.

Termination of the complete command string by <CR>.

String 1 ; string 2 ; string 3 ; ... ; string n-1 ; string n <CR>

Fig. 1 Syntax

1.4 Characters

Delimiters

between command word and parameter or between two parameters:

- ▶ ", " (comma)

between two complete commands:

- ▶ "; " (semicolon)

Terminators

- ▶ <CR> (carriage return)

Special characters

- ▶
- ▶ <BS>

An erroneously entered character can be cleared by

 (delete, rubout) or
<BS> (backspace).

- ▶ <ETX> (on keyboard <CTRL> + "C")
- ▶ <CR> (carriage return)

Termination of continuous output

If the continuous data output has been started on the terminal interface, eg output of the traffic-announcement identification (TA), this output can be terminated by entering the <ETX> character (press <CTRL> + "C" simultaneously) or by <CR> (carriage return).

The terminal interface signals again the prompt.

Termination of outputs and inputs

The DMDC once more returns to the basic mode.

Switch-on test

After switch-on, the equipment performs a warm start and then returns to the basic mode. After the output of status information, the equipment signals a prompt.

1.5 Output Buffer Capacity

An output buffer is provided in the equipment.

If data taken from the continuously incoming RDS data stream are output from the device on the terminal interface, it is possible that the output capacity of the interface will not be sufficient.

The output capacity of the interface is determined by the following conditions:

- ▶ Selected baud rate
- ▶ Effective baud rate determined by hardware handshake

1.6 Data Memory

Using the DISP command it is possible to select the RDS data memory from which the information for the terminal interface is to be taken.

Data are taken from the RDS data memory DISP2 after switch-on of the device. Switchover to another RDS data memory remains in force until a warm start or another switchover is performed.

2 List of all Commands Defined

Command	Parameter	Function
AC	---	User code
AC10	---	User code 10
AC11	---	User code 11
AC13	---	User code 13
ACK	X 1 ... 64 NETZ QU INFO PGL PH R-V STR	Clearing of fault memories
ACON	---	User code (other networks)
AF	R[EAD],1 ... 32 N[EW]	Output of received alternative frequencies
AFL	FRQ	Listing of all alternative frequencies
AFON	---	Output of alternative frequencies (other networks)
AI	---	Output of RDS information
BL	---	Start of outputting block error rate
BLERR	---	Limit values of transmission link (block error)
CLEAR	see ACK	(see command AF)
CT	R[EAD],1 ... 32 C[HANGE] N[EW]	Output of RDS information "clock time"
DECODE	* 0 1 ... 15	Undecoded output of block information
DI	R[EAD],1 ... 32 C[HANGE] N[EW]	Output of decoder identification
DISP	1 2	Selection of RDS data memory for data output
DS	0 1, ..., 7, 8 X	Setting of data set address for data link
EG	---	Output "Extended Generic Indicator"
FAULT		Output of stored fault messages
GR	R[EAD],1 ... 32 N[EW]	Output of group numbers
HELP	INFO EON BLOCK EINSTELLUNGEN EXTRA	Output of command overview
IH	R[EAD] 0 ... 31 X A	Output of inhouse-application information
IHON	---	Output of inhouse-application information (EON)
INFO	A,B ANZAHL ZEIT	Limit value monitoring of information changes
INHIB	[,(B CODER C TPZ D IH) [,A ,K (.AF ,D ,IH ,MS ,PI ,PIN ,PS ,PTY ,RT ,TA ,TDC ,TP)] [,(S ET) [,A ,K (.AF ,D ,IH ,MS ,PI ,PIN ,PS ,PTY ,RT ,TA ,TDC ,TP)] [,EIN ,AUS ,0 1,)]	Inhibition of interfaces CODER, TPZ and IH Note for DMC01 and DMC01C: Interface assignment is not possible since only one interface is available. For this reason, the first line of the command in the column to the left is omitted.
LA	---	Information group 1A "Linkage Actuator"
LAON	---	Output EON information "Linkage Actuator" (other networks)
LINK	ON OFF	Coupling ON/OFF
LN	---	Output EON information "Linkage Number" (ILS + LSN or ILS + CI + LI)
LVL	A,B TOL_DB ZEIT	Limit values of level monitoring

*) Output of additional measured values on devices with "measurement function"

**Operation Decoder DMC01 - DMDC
Terminal Protokoll**

Command	Parameter	Function
LVLC	KORR_DB	Value of level correction
MENU	---	Menu overview
MODE	ERR KORR R2/5 KORR1 KORR2	Reading out/setting error correction mode
MONITOR	---	Overview of important information
MS	R[READ],1 ... 32 C[HANGE] N[EW]	Output of music-speech identification
MVAL	---	Single output of measured values *)
MVP	1...3600	Periodical output of measured values *)
PAGING	<Intervall> <Pageradresse> X	Output paging information
PH	A,B TOL_GRAD ZEIT	Limit values for RDS-pilot phase
PHC	KORR_GRAD	Value of phase correction
PI	R[READ] C[HANGE] N[EW]	Output of program identification
PIN	R[READ] C[HANGE] N[EW]	Output of program item number
PINON	---	Output of program item number (other networks)
PION	---	Output of program identification (other networks)
POWER	A,B ZEIT	Limit values of power monitoring
PS	R[READ] C[HANGE] N[EW]	Output of program service name
PTY	R[READ] C[HANGE] N[EW]	Output of program type
PTYON	---	Output of program type(other networks)
R-V or VRF	A,B TOL_GRAD ZEIT	Limit values for RDS-VRF phase
R-VC or CORRVRFB	KORR_GRAD	Value of RDS-VRF phase correction
RT	R[READ] N[EW]	Output of radiotext
SET	PAGE TERM	Performing the setup
SHOW	---	Output of limit values and settings
SOURCE	1,...,8 X REF_PI REF_PS REF_TP J,N,D	Input/output of source monitoring
SRCE A SRCE B	A,B TOL_ANZ	Limit values of source monitoring
SY	SYNC NOSYNC	Beginning of output of synchronization state
TA	R[READ] C[HANGE] N[EW]	Output of traffic-announcement identification
TAON	---	Output of traffic-announcement identification (other networks)
TDC	R[READ] 0 ... 31 X A	Output of transparent data channel
TEST	RAM ROM BATT I/O PREEPROCESSOR FRONT,TERMINAL,CODER,TPZ,IH	Activation of self-test functions Note for DMC01 and DMC01C: see EBU manufacturer's commands
TP	R[READ] C[HANGE] N[EW]	Output of traffic-program identification
TPON	---	Output of traffic-program identification (other networks)
1A ... 15B	1A 1B 3A 3B 4A 4B 5A 5B 7A 7B 8A 8B 9A 9B 10A 10B 11A 11B 12A 12B 13A 13B 14A 14B 15B	Output of block contents (not formatted)

3 Message description

Command and default syntax

The symbols used in the commands have the following meaning:

- [] Optional parameter of command
- | Only one of the options separated by | is allowed (exclusive OR).
- || Any number of the options separated by || can be used simultaneously in an command set (logic OR).
- ? Missing parameters are interrogated.

AC Command

By entering the command AC, the the user code in group 14A, block 3, bit 1 to 4 is output as a decimal value.

Syntax:

AC (without parameter)

Range: 0 to 7 (decimal)

AC10 Command

By entering the command AC10, the contents in group 14A, block 3, bit 1 to 16 which have not yet been defined, is output as a hexadecimal value.

Syntax:

AC10 (without parameter)

Range: 0000 to FFFF (hex)

Notes on EON outputs:

All EON outputs consist of the PI-ON (program identification of the "other" network) followed by the information desired.

PI-ON is output at the beginning of each screen line and also within one line following a change to another "other" network.

AC11 Command

By entering the command AC11, the contents in group 14A, block 3, bit 1 to 16 which have not yet been defined, is output as a hexadecimal value.

Syntax:

AC11 (without parameter)

Range: 0000 to FFFF (hexadecimal)

See indication of the EON output for the command AC10

AC12 Command

By entering the command AC12, the contents in group 14A, block 3, bit 3 which have not yet been defined, is output as a hexadecimal value.

Syntax:

AC12 (without parameter)

Range: 0 or 1

See indication of the EON output for the command AC10

AC13 Command

By entering the command AC13, the contents in group 14A, block 3, bit 6 to 15 which have not yet been defined, is output as a hexadecimal value.

Syntax:

AC13 (without parameter)

Range: 000 to FFF (hex)

See indication of the EON output for the command AC10

ACK Command

Entering the ACK command and a termination character clears the fault memories of the DMDC. Front-panel LEDs TOL A and TOL B are updated in accordance with the new memory state.

Syntax:

ACK

[,X|,1|...|,64|,POWER|,SRCE|,INFO
|,LVL|,PH|,R-V|,BLERR]

Default: ACK, X

Parameters:

- ▶ X
Clear all faults stored.
- ▶ 1 | ... | 64
Clear fault No. ...
- ▶ POWER
Clear all power failures stored.
- ▶ SRCE
Clear all source faults stored.
- ▶ INFO
Clear all information errors stored.
- ▶ LVL
Clear all stored level faults of RDS signal.
- ▶ PH
Clear all phase errors (RDS-pilot phase) stored.
- ▶ R-V
Clear all phase errors (RDS-VRF phase) stored.
- ▶ BLERR
Clear all transmission errors stored (out-of-tolerance block error rates).

ACON Command

By entering the command ACON, the contents in group 14B, block 2, bit 14 to 16 which have not yet been defined, is output as a hexadecimal value.

Syntax:

ACON (withot parameter)

Range: 0 to 7

See indication of the EON output for the command AC10.

AF Command

Output of received alternative frequencies.

Syntax:

AF [,R[EAD],(1|...|32)]|[,N[EW]]

Default: AF,NEW

Parameters:

- ▶ R[EAD],1|...|32
Read last AF list(s) received from one of RDS data memories.
- ▶ N[EW]
Continuous output of all incoming AF lists until the entry of <ETX> or <CR> stops the output.

The list of alternative frequencies output has the following format:

- ▶ The frequencies are combined in pairs. These pairs correspond to the two frequencies entered in group 0A of block 3.
- ▶ (FREQ 1,#N)
The list of alternative frequencies applies to the frequency FREQ1 and consists of N frequencies.
- ▶ (FREQ M, FREQ M + 1)
Frequency pair consisting of FREQ M and FREQ M + 1
- ▶ FILL
Fillup code
- ▶ MW
Medium-wave frequency
- ▶ LW
Long-wave frequency

The data are taken from the selected RDS data memory, ie DISP1 or DISP2.

AFL Command

Output of the AF lists stored in data memory DISP2.

Syntax:

AFL [,FREQ]

Default: AFL,?

The AF lists are output in the order received starting with the entered frequency. If this frequency is not on the list, the next higher frequency is used.

Parameter:

- ▶ FREQ
Values between 87.5 and 107.9

Note:

A fullstop (.) is used for decimal notation.

AFON Command

By entering the command AFON, the output of the received alternative frequencies of the "other" network is initiated. The type of the list is identified.

Syntax:

AFON (without parameter)

See indication of the EON output for the command AC10.

AI Command

Single output of stored RDS information from the selected RDS data memory, DISP1 or DISP2, as well as measured values and status information.

- ▶ Output of RDS information
PI, PS, TP, TA, DI, MS, PTY, PIN
- ▶ Output of the last eight radiotexts received.
The radiotext received last is the last text output.
- ▶ Output of the CT RDS information
- ▶ Output of the last 64 TDC information items received
- ▶ Output of the last 64 IH information items received

If a whole page has been written on the terminal, the DMDC waits for the entry of any character to continue the output. Further information output can be stopped by entering <ETX>.

This query at the end of a full page can be enabled and disabled using the SET command.

Example of command: AI

AION Command

With command AION entered on the terminal it is possible to display the EON information of the RDS memory DISP1 or DISP2.

Syntax:

AION (without parameter)

Sequence of output:

PION, PSON, AFON, EG, LAON, LN, PTYON, TPON, TAON, PINON, IHON, AC10, AC11, AC12, AC13, ACON

See indication of the EON output for the command AC10.

BL Command

The BL command starts the continuous output of the block error rate. The block error rate is output following the command and then every second. The block error rate applies to the selected mode of operation, ie error detection or error correction.

Syntax:

BL (without parameter)

Default: BL

The block error rate covers the following range:

- ▶ Minimum 0%
- ▶ Maximum 100%

The output of the block error rate is terminated by entering <ETX>.

Example of command: BL

CT Command

Output of the RDS information "clock time".

Syntax:

CT [,R[EAD]]|[,C[HANGE]]|[,N[EW]]

Default: CT,NEW

Parameters:

- ▶ R[EAD]
The RDS information is read out from the RDS data memory selected. If no information is stored in the specific RDS memory, there is no output.
- ▶ C[HANGE]
The RDS information is read out as for READ. Further outputs follow the next change of the RDS information.
- ▶ N[EW]
All incoming RDS information items are output at the terminal interface until <ETX> is entered.

The data are taken from the RDS data memory selected, ie DISP1 or DISP2.

Example of command: CT,READ

DECODE Command

This command permits undecoded output of the information contained in the blocks. The output can be restricted to individual groups. For outputting a large number of groups, the capacity of the output buffer has to be borne in mind.

Syntax:

DECODE,*|(0||1||...||14||15)

Default: None

Parameters:

- ▶ *
- ▶ All identified incoming groups are output.
- ▶ 0 || 1 || ... || 14 || 15
The information included in the groups listed is output.

Example of command: **DECODE,1,4,7**

Output of groups 1, 4, 7 (paging information)

DI Command

Output of RDS decoder identification.

Syntax:

DI [,R[**EAD**]]|[,C[**HANGE**]]|[,N[**EW**]]

Default: **DI,NEW**

Parameters:

- ▶ **R[**EAD**]**
The RDS DI information is read out from the RDS data memory selected. If no information is stored in the specific RDS memory, there is no output.
- ▶ **C[**HANGE**]**
The RDS information is read out as for **READ**. Further outputs follow the next change of the RDS information.
- ▶ **N[**EW**]**
This command starts the continuous output of the DI decoder bit. All incoming RDS information items are output at the terminal interface until <ETX> is entered.

The data are taken from the RDS data memory selected, ie **DISP1** or **DISP2**.

Example of command: **DI**

DISP Command

This command selects the RDS data memory from which the RDS data are to be taken for the terminal interface.

Syntax:

DISP [,1|2]

Default: **DISP,?**

Parameters:

- ▶ 1
RDS data for the terminal interface are read from the RDS data memory **DISP1**.
- ▶ 2
RDS data for the terminal interface are read from the RDS data memory **DISP2** (information memory).

Example of command: **DISP,2**

DS Command

This command selects the data set address for the data link.

Syntax:

DS [(1|2|...|8|X|0)]

Default: **DS,?**

Parameters:

- ▶ 1, ..., 7, 8
The output of the data link is addressed to the data set indicated.
- ▶ X
The output of the data link is addressed to all data sets.
- ▶ 0
The output of the data link is addressed to the data set transmitted.

Example of command: **DS,2**

GR Command

Output of RDS group numbers.

Syntax:

GR [,R[EAD]]|[,N[EW]]

Default: **GR,NEW**

Parameters:

- ▶ **R[EAD]**
The group numbers of the last 64 RDS groups received are output. After starting the command, the data from the RDS data memory are copied into a terminal memory so that the data are available at the terminal irrespective of the duration of the output.
- ▶ **N[EW]**
This command starts the continuous group output. After decoding the incoming group, the group number is output in the following format:
 - ▶ in hexadecimal notation
 - ▶ group type with the character A or B

The group numbers of further incoming RDS information items are output on the terminal until entry of <ETX>.

Example of command: **GR,R**

The data are taken from the RDS data memory selected, ie DISP1 or DISP2.

HELP Command

Output of implemented commands and parameters of terminal interface.

Syntax:

HELP [,INFO]|[,EON]|[,BLOCK]|[,SELECTION]|[,EXTRA]

Default: **HELP,?**

Parameters:

- ▶ **INFO**
List of commands and their parameters outputting RDS information
- ▶ **EON**
List of commands and their parameters outputting EON data
- ▶ **BLOCK**
List of commands and their parameters outputting information of special group blocks

▶ **SELECTION**

List of commands and their parameters allowing the selection of tolerance limits and other parameters

▶ **EXTRA**

List of additional commands

Example of command: **HELP,INFO**

IH Command

Output of RDS inhouse-application information.

Syntax:

IH [(0|...|31|X)|,A]|[,R[EAD]|,A]]

Default: **IH,?**

Parameters:

- ▶ **R[EAD]**
The information items of the last 64 RDS groups received are output. After starting the command, the data from the RDS data memory are copied into a terminal memory so that the data are available at the terminal irrespective of the duration of the output.
- ▶ **0|...|31|X**
Channel number of the IH information which is to be output. After starting the program, continuous output of the IH information is started. If the parameter X is entered, all incoming IH information items are output. Information output is stopped by entering <ETX>.
- ▶ **A**
IH information is read and output in ASCII and not in hexadecimal form.

If several channels are output simultaneously, the channel number is always included in the output.

Output format:

CHANNEL NUMBER,INFORMATION
(ASCII characters)

For outputting only one channel, the channel number is not indicated. One information item follows the other without space.

Output format:

INFORMATION,INFORMATION
(ASCII characters)

If no parameter is specified, the IH information is output in hexadecimal form.

Output format:

CHANNEL NUMBER,INFORMATION
(hexadecimal characters)

Channel numbers are output in decimal form.

Example of command: IH,7,A

In RDS group 6A, the IH information consists of four hexadecimal characters, in RDS group 6B of two hexadecimal characters.

The data are taken from the RDS data memory selected, ie DISP1 or DISP2.

IHON Command

With command IHON entered on the terminal it is possible to display the Inhouse-Informationen of the "other" networks.

Syntax:
IHON (without parameter)

See indication of the EON output for the command AC10.

INFO Command

Limit values for information change monitoring.

Syntax:
INFO [B|,A][,NUMBER][,PERIOD]

Default: INFO,?

Parameters:

- ▶ A, B
Tolerance class for which the limit value is to be valid
- ▶ NUMBER
Number of information changes causing a fault message
- ▶ PERIOD
Period during which the information changes are added

Example of command: INFO,B,2,20

COUPLE Command

Switching data set coupling on and off

Syntax:
COUPLE [,ON|,OFF]

Default: COUPLE,?

Parameters:

- ▶ ON
Activation of source monitoring is coupled to addressing of the data link.
- ▶ OFF
Coupling of source monitoring to data link addressing is switched off.

Example of command: COUPLE,OFF

LA Command

Readout Linkage Aktuator

Syntax:
LA (without parameter)

Range: 0 or 1

See indication of the EON output for the command AC10.

LAON Command

Readout Linkage Aktuator of the "other" networks.

Syntax:
LAON (without parameter)

Range: 0000 to FFFF

See indication of the EON output for the command AC10.

LN Command

Readout Linkage Set Number of the "other" networks.

Syntax:

LN *(without parameter)*

Range: 0000 to 1FFF

See indication of the EON output for the command AC10.

MENU Command

Menu structure overview.

Example of command: MENU

MODE Command

Reading out and setting of error correction mode. See section 3.2.2.

Syntax:

MODE [, (DET|COR[R2/5])| (CORR1|CORR2)]

Default: MODE,?

Example of command: MODE,COR

MONITOR Command

Overview of important RDS information, measured values and fault messages.

For using this command, a VT220-compatible terminal is required.

Prior to starting the command the terminal mode must be selected (SET,TERM,VT220) using the setup command.

Syntax:

MONITOR *(without parameter)*

Default: MONITOR

The following information items are output and continuously updated:

RDS level, RDS-pilot phase, RDS-VRF phase, block error rate (in %), synchronization state, PI, PS, TP, TA, DI, MS, PTY, PIN, CT, power failure, source fault, information error, level error, RDS-pilot phase error, RDS-VRF phase error, block error, radiotext.

Example of command: MONITOR

MS Command

Output of music-speech identification.

Syntax:

MS [,R[EAD]]| [,C[HANGE]]| [,N[EW]]

Default: MS,NEW

Parameters:

- ▶ R[EAD]
The RDS information is read out from the RDS data memory selected. If no information is stored in the specific RDS memory, there will be no output.
- ▶ C[HANGE]
The RDS information is read out as for READ. Further outputs follow the next change of the RDS information.
- ▶ N[EW]
This command starts the continuous output of the music-speech identification.

Output of character M corresponds to information 1 and output of character S to information 0.

The data are taken from the RDS data memory selected, ie DISP1 or DISP2.

MVAL Command

Output of measured values (only on devices with measurement function).

Syntax:

MVAL *(without parameter)*

Default: MVAL

After entering the command, the following measured values are output once: RDS level, RDS-pilot phase, RDS-VRF phase, block error rate and synchronization state.

Example of command: MVAL

MVP Command

Periodical output of measured values.

Syntax:

MVP [(1...3600)]

Default: MVP,?

Parameter:

- ▶ 1 ... 3600
Duration of measured value output. Output same as with MVAL command.

Example of command: MVP,10

LVLC Command

Value of level correction.

Syntax: LVLC[,CORR_DB]

Default: LVLC,?

Parameter:

- ▶ CORR_DB
Level correction

Example of command: LVLC,2.2

POWER Command

Limit values for monitoring AC supply voltage.

Syntax:

POWER [,B|,A],[TIMEOUT]

Default: POWER,?

Parameters:

- ▶ A, B
Tolerance class for which the limit value is to be valid
- ▶ TIMEOUT
Timeout for triggering a power failure message

Example of command: POWER,A,10

PAGING Command

With command PAGING entered on the terminal it is possible to display the transmitted paging calls of group 7A on a terminal. Depending on the mode of the transmitted call, four possibilities are offered:

- ▶ call number only for tone call (without any message)
- ▶ call number and subsequently 10 digits (eg for transmitting a telephone number)
- ▶ call number and subsequently 18 digits (eg for transmitting a longer telephone number)
- ▶ call number and subsequently alphanumeric characters (eg for texts of 76 characters max.)

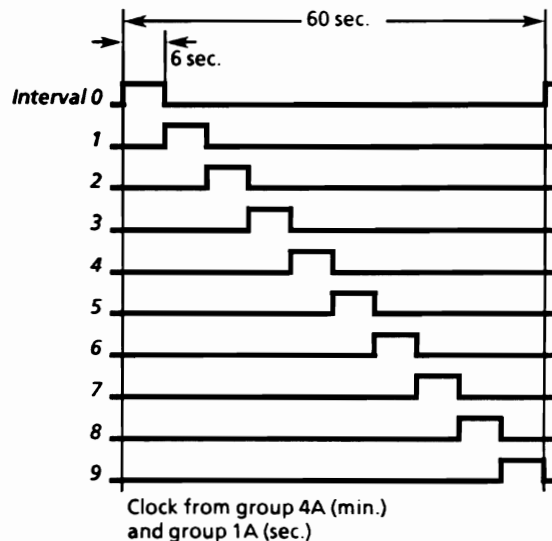

Further parameters of the command allow limiting the incoming data to a paging interval (interval = 0 to 9) or to a call number (pager address = 000000 | ... | 999999).

LVL Command

Limit values of level monitoring.

Syntax:

LVL [,B|,A],[TOL_DB],[TIMEOUT]

Default: LVL,?

Parameters:

- ▶ A,B
Tolerance class for which the limit value is to be valid
- ▶ TOL_DB
Tolerance range in dB
- ▶ TIMEOUT
Timeout for triggering a level fault message

Command X outputs all incoming calls.

NOTE:

The only parameter that can be used with the current software version is parameter X.

Syntax:

PAGING

[[,<Interval>]
[,<Pageraddress>]
[,X]

Parameter:

- ▶ "Interval"
The paging interval is used by the pager for synchronization (eg in battery save mode)
- ▶ "Pageraddress"
six-digit address of a pager (000000 | ... | 999999)
(the last digit of the address 0 to 9 corresponds to the pager interval)
- ▶ "X"
for outputting all received calls (all intervals, all addresses)

PH Command

Limit values for monitoring the RDS-pilot phase.

Syntax:

PH [,A|,B][,TOL_DEGREE][,TIMEOUT]

Default: PH,?

Parameters:

- ▶ A, B
Tolerance class for which the limit value is to be valid
- ▶ TOL_DEGREE
Tolerance range in degrees
- ▶ TIMEOUT
Timeout for triggering a phase fault message

Example of command: PH,A,10,1m

PHC Command

Value of phase correction.

Syntax:

PHC [,CORR_DEGREE]

Default: PHC,?

Parameter:

- ▶ CORR_DEGREE
Phase correction

Example of command: PHC,5

PI Command

Output of program identification.

Syntax:

PI [,R[EAD]]|[,C[HANGE]]|[,N[EW]]

Default: PI,NEW

Parameters:

- ▶ R[EAD]
The RDS PI information is read out from the RDS data memory selected. If no information is stored in the specific RDS memory, there will be no output.
- ▶ C[HANGE]
The RDS information is read out as for READ. Further outputs follow the next change of the RDS information.
- ▶ N[EW]
This command starts the continuous output of the program identification.

Output of the PI information is in hexadecimal form.

The data are taken from the RDS data memory selected, ie DISP1 or DISP2.

PIN Command

Output of program item number.

Syntax:

PIN [,R[EAD]]|[,C[HANGE]]|[,N[EW]]

Default: PIN,NEW

Parameters:

- ▶ R[EAD]
The RDS PIN information is read out from the RDS data memory selected. If no information is stored in the specific RDS memory, there will be no output.
- ▶ C[HANGE]
The RDS information is read out as for READ. Further outputs follow the next change of the RDS information.
- ▶ N[EW]
This command starts the continuous output of the program item number.

The data are taken from the RDS data memory selected, ie DISP1 or DISP2.

PINON Command

Output of program item number of other networks

Syntax:

PINON (without parameter)

Siehe Hinweis der EON-Ausgabe bei Befehl AC10

PION Command

Output of program identification of other networks

Syntax:

PION (without parameter)

See indication of the EON output for the command AC10.

PS Command

Output of program service name.

Syntax: **PS**[,R[EAD]]|[,C[HANGE]]|[,N[EW]]

Default: **PS,NEW**

Parameters:

- ▶ **R[EAD]**
The RDS PS information is read out from the RDS data memory selected. If no information is stored in the specific RDS memory, there will be no output.
- ▶ **C[HANGE]**
The RDS information is read out as for READ. Further outputs follow the next change of the RDS information.
- ▶ **N[EW]**
This command starts the continuous output of the program service name.

A complete PS information consists of eight characters. If certain parts of the PS information cannot be received, these are marked by blanks when output on the terminal interface.

The data are taken from the RDS data memory selected, ie DISP1 or DISP2.

Example of command: **PS,CHANGE**

PTY Command

Output of program type.

Syntax: **PTY**[,R[EAD]]|[,C[HANGE]]|[,N[EW]]

Default: **PTY,NEW**

Parameters:

- ▶ **R[EAD]**
The RDS PTY information is read out from the RDS data memory selected. If no information is stored in the specific RDS memory, there will be no output.
- ▶ **C[HANGE]**
The RDS information is read out as for READ. Further outputs follow the next change of the RDS information.
- ▶ **N[EW]**
This command starts the continuous output of the program service name.

The data are taken from the RDS data memory selected, ie DISP1 or DISP2.

Example of command: **PTY**

PTYON Command

Readout of program type of "other" networks

Syntax:

PTYON (without parameter)

See indication of the EON output for the command AC10.

SOURCE Command

Input and output of reference memories for source monitoring.

Syntax:

SOURCE

[1|...|8|X[REF_PI[REF_PS[REF_TP[Y|N|D]]]]]

Default: **SOURCE,?**

Parameters.

- ▶ 1, ..., 8
Reference memory which is to be written or read.
- ▶ X
All reference memories are set to the same values.
- ▶ REF_PI

Operation Decoder DMC01 - DMDC Terminal Protokol

Value of RDS PI information which is to be written into the reference memory. Entry of a 4-digit hex character.

- ▶ REF_PS
Value of RDS PS information which is to be written into the reference memory. The entry must consist of 8 characters. If # is entered, this character is not checked during source monitoring. Entries of ",", ";", "#" and "\" must be preceded by "\".

Example: "\", "\", "\", "#"

- ▶ REF_TP
Value of RDS TP information which is to be written into the reference memory.

Value: 0 or 1.

- ▶ Y, N, D
Switching source monitoring on and off. Parameter D selects data set coupling (see SOURCE menu).

If parts of the parameters REF_PS or REF_TP are not be checked during source monitoring, # has to be entered.

Example of command:
SOURCE,1,1234,RDS000PS,1,N

SRCE,A/SRCE,B Command

Limit values of source monitoring.

Syntax:

SRCE(,A|,B)[,TOL_NO]

Default: SRCE,A,? or SRCE,B,?

Parameters:

- ▶ A, B
Tolerance class for which the limit value is to be valid.
- ▶ TOL_NO
Number of out-of-tolerance values of the activated source up to triggering a source fault message.

Example of command: SRCE,A,15

R-V Command

Limit values for monitoring the RDS-VRF phase.

Syntax:

R-V [,A|,B][,TOL_DEGREE][,TIMEOUT]

Default: R-V,?

Parameters:

- ▶ A, B
Tolerance class for which the limit value is to be valid
- ▶ TOL_DEGREE
Tolerance range in degrees
- ▶ TIMEOUT
Timeout for triggering an RDS-VRF phase fault message

Example of command: R-V,A,10,1m

R-VC Command

Value of RDS-VRF phase correction.

Syntax:

R-VC [,CORR_DEGREE]

Default: R-VC,?

Parameter:

- ▶ CORR_DEGREE
RDS-VRF phase correction

Example of command: R-VC,5

RT Command

Output of radiotext.

Syntax:

RT [,R[EAD]] [,N[EW]]

Default: RT,NEW

Parameters:

- ▶ R[EAD]
The last eight RDS RT information items received are read from the selected RDS memory. If no information is stored in the specific RDS memory, there will be no output.
- ▶ N[EW]
This command starts the continuous output of the incoming RDS RT information.

If the data are taken from the RDS data memory DISP1, it is possible to observe the incoming radiotexts arriving one after the other. If the data are read from information memory DISP2, the radiotext is output only after it has been completely received.

Example of command: RT,R

SET Command

Command only with DMDC...

Performing the setup.

Syntax:

SET [,PAGE[,ON,OFF)]] [,TERM[,VT220 | NOVT220)]]

Default: **SET,?**

Parameters:

- ▶ **PAGE**
Page interrogation after writing a complete page with non-continuous data
- ▶ **TERM**
A VT220-compatible terminal is connected to the interface.

SHOW Command

Output of limit values and settings.

Syntax:

SHOW (*without parameter*)

Default: **SHOW**

The following information is output:

RDS-pilot phase correction, level correction, RDS-VRF phase correction, limit values of power failure, limit values of source fault, limit values of information change, limit value of level error, limit value of RDS-pilot phase error, limit value of RDS-VRF phase error, limit value of block error, error correction mode, data set address mode, reference memory, source monitoring, inhibited parameters of CODER (B), TPZ (C) and IH(D) interfaces.

Example of command: **SHOW**

INHIB Command

Inhibition of data output on the link interfaces CODER (B), TPZ (C), ie audio quality monitoring, and IH (D).

Syntax:

INHIB

[,B|CODER|C|TPZ|D|IH)[,AI|,NI|,(AF)||,DI||IH||,MS||,PI||,PIN||,PS||,PTY||,RT||,TA||,TDC||,TP)]]

Default: **INHIB,?**

Parameters:

- ▶ **B, CODER**

Inhibition of CODER interface which can also be addressed with B

- ▶ **C, TPZ**
Inhibition of TPZ interface which can also be addressed with C
- ▶ **D, IH**
Inhibition of IH interface which can also be addressed with D
- ▶ **AI**
Output of all information items is inhibited.
- ▶ **NI**
Output of no information item is inhibited.
- ▶ **Name of information**
Output of the information mentioned is inhibited.

Examples of command:

INHIB,B,AF,IH,TDC,TP or **INHIB,C,AI**

FAULT Command

This command permits output of the fault messages stored in the DMDC.

Syntax: **FAULT** (*without parameter*)

Default: **FAULT**

The fault message output includes the following information:

- ▶ Cause of fault (eg block error)
- ▶ Exceeded tolerance class (A,B)
- ▶ Maximum/minimum value to be monitored during the fault (eg -10°)
- ▶ Beginning of fault with date and time of the day (DD.MM.YY HH:MM:SS)
- ▶ End of fault with time of the day (HH:MM:SS)
- ▶ Duration of fault in hours, minutes and seconds (HH:MM:SS)

If a fault takes more than 100 hours, this is marked by ">".

BLERR Command

Limit values for monitoring the transmission link (block error rate).

Syntax:

BLERR [,A|,B][,TOL_PERCENT][,TIMEOUT]

Default: **BLERR,?**

Parameters:

- ▶ **A, B**

Tolerance class for which the limit value is to be valid

- ▶ TOL_PERCENT
Tolerance range in %
- ▶ TIMEOUT
Timeout for triggering a fault message

Example of command: **BLERR,A,25,20**

SY Command

Syntax:

SY (without parameter)

Default: SY

The SY command starts the continuous output of the synchronization state. The synchronization state is output following the command and then every second.

The outputs have the following meaning:

- ▶ SYNC
The DMDC is able to carry out a block synchronization.
- ▶ NOSYNC
The DMDC is unable to carry out a block synchronization.

Output of the block error rate is terminated by entering <ETX>.

Example of command: SY

TA Command

Output of traffic announcement identification.

Syntax:

TA [,R[EAD]]|[,C[HANGE]]|[,N[EW]]

Default: TA,NEW

Parameters:

- ▶ R[EAD]
The RDS TA information is read out from the RDS data memory selected. If no information is stored in the specific RDS memory, there will be no output.
- ▶ C[HANGE]
The RDS information is read out as for READ. Further outputs follow the next change of the RDS information.
- ▶ N[EW]
This command starts the continuous output of the traffic-announcement identification.

A figure 1 stands for a traffic announcement whereas a 0 identifies a program without traffic announcement.

The data are taken from the RDS data memory selected, ie DISP1 or DISP2.

TAON Command

Output of traffic announcement of "other" networks

Syntax:

TAON (without parameter)

See indication of the EON output for the command AC10.

TDC Command

Continuous output of the transparent data channel information.

Syntax:

TDC [, (0 | ... | 31 | X) [, A]] | [, R[EAD]] [, A]]

Default: TDC,?

Parameters:

- ▶ R[EAD]
The information items of the last 64 RDS groups received are output. After starting the command, the data from the RDS data memory are copied into a terminal memory so that the data are available at the terminal irrespective of the duration of the output.
- ▶ 0 | ... | 31 | X
Channel number of the TDC information which is to be output. After starting the program, continuous output of the TDC information is started. All TDC information items arriving after the start of the command are output. If the parameter X is entered, all incoming TDC information items are output. Information output is stopped by entering <ETX>.
- ▶ A
TDC information is read and output in ASCII and not in hexadecimal form.

If several channels are output simultaneously, the channel number is always included in the output.

Output format:

CHANNEL NUMBER,INFORMATION
(ASCII characters)

For outputting only one channel, the channel number is not indicated. One information item follows the other without space.

Output format:

INFORMATION,INFORMATION
(ASCII characters)

If no parameter is specified, the TDC information is output in hexadecimal form.

Output format:

CHANNEL NUMBER,INFORMATION
(hexadecimal characters)

Channel numbers are output in decimal form.

Example of command: TDC,7,A

The data are taken from the RDS data memory selected, ie DISP1 or DISP2.

TEST Command

Command only with DMDC...

Activation of self-test functions.

Syntax:

TEST
[(RAM|ROM|BATT|I/O|PREPROCESSOR|
FRONT|TERMINAL|CODER|TPZ|IH)]

Default: TEST,?

Parameters:

- ▶ RAM
RAM test
- ▶ ROM
ROM test
- ▶ BATT
Battery test
- ▶ I/O
Test of I/O interface
- ▶ PREPROCESSOR
Preprocessor test
- ▶ FRONT, TERMINAL, CODER, TPZ, IH
Test of the corresponding interface. The interface under test cannot be used during the test.

TP Command

Output of traffic program identification

Syntax:

TP [,R[READ]]|[,C[HANGE]]|[,N[EW]]

Default: TP,NEW

Parameters:

- ▶ R[READ]
The RDS TP information is read out from the RDS data memory selected. If no information is stored in the specific RDS memory, there will be no output.
- ▶ C[HANGE]
The RDS information is read out as for READ. Further outputs follow the next change of the RDS information.
- ▶ N[EW]
This command starts the continuous output of the traffic-program identification.

A Y stands for a traffic announcement transmitter whereas an N identifies a transmitter without traffic announcements.

The data are taken from the RDS data memory selected, ie DISP1 or DISP2.

TPON Command

Readout of traffic program identification of the "other" networks

Syntax:

TPON (without parameter)

See indication of the EON output for the command AC10.

**Command for Output
of Unformatted Block Contents**

Commands:

"1A", "1B", "3A", "3B", "4A", "4B",
 "5A", "5B", "7A", "7B", "8A", "8B",
 "9A", "9B", "10A", "10B", "11A",
 "11B", "12A", "12B", "13A", "13B",
 "14A", "14B", "15B"

All outputs are in hexadecimal notation. If, when entering an command for a group of type A, a group of type B is received, this is indicated by outputting"(B)" and vice versa.

For commands and examples of output format see following text.

Commands and examples of output format:

X = characters 1 to F # = none

Command	Output format	Source
1A	1A(RP): XX,XXXX,####	5 bits from block 2 and 16 bits from block 3
1B	1B: XX,####,####	5 bits from block 2
3A	3A: XX,XXXX,XXXX	5 bits from block 2 and 16 bits from block 3 and 16 bits from block 4
3B	3B: XX,####,XXXX	5 bits from block 2 and 16 bits from block 4
4A	4A: XX,####,####	5 bits from block 2
4B	4B: XX,####,XXXX	5 bits from block 2 and 16 bits from block 4
5A	5A: XX,XXXX,XXXX	5 bits from block 2 and 16 bits from block 3 and 16 bits from block 4
5B	5B: XX,####,XXXX	5 bits from block 2 and 16 bits from block 4
7A	7A: XX,XXXX,XXXX	5 bits from block 2 and 16 bits from block 3 and 16 bits from block 4
7B	7B: XX,####,XXXX	5 bits from block 2 and 16 bits from block 4
8A	8A: XX,XXXX,XXXX	5 bits from block 2 and 16 bits from block 3 and 16 bits from block 4
8B	8B: XX,####,XXXX	5 bits from block 2 and 16 bits from block 4
9A	9A: XX,XXXX,XXXX	5 bits from block 2 and 16 bits from block 3 and 16 bits from block 4
9B	9B: XX,####,XXXX	5 bits from block 2 and 16 bits from block 4
10A	10A: XX,XXXX,XXXX	5 bits from block 2 and 16 bits from block 3 and 16 bits from block 4
10B	10B: XX,####,XXXX	5 bits from block 2 and 16 bits from block 4
11A	11A: XX,XXXX,XXXX	5 bits from block 2 and 16 bits from block 3 and 16 bits from block 4
11B	11B: XX,####,XXXX	5 bits from block 2 and 16 bits from block 4
12A	12A: XX,XXXX,XXXX	5 bits from block 2 and 16 bits from block 3 and 16 bits from block 4
12B	12B: XX,####,XXXX	5 bits from block 2 and 16 bits from block 4
13A	13A: XX,XXXX,XXXX	5 bits from block 2 and 16 bits from block 3 and 16 bits from block 4
13B	13B: XX,####,XXXX	5 bits from block 2 and 16 bits from block 4
14A	14A: XX,XXXX,XXXX	5 bits from block 2 and 16 bits from block 3 and 16 bits from block 4
14B	14B: XX,####,XXXX	5 bits from block 2 and 16 bits from block 4
15B	15B: XX,XXXX,XXXX	5 bits from block 2 and 16 bits from block 3 and 16 bits from block 4

4 Terminal Protokol

The terminal protocol complies with specifications No. 5/3.8, part I (basic unit), of the broadcasting corporations under public law in the Federal Republic of Germany.

Table 1: Input via Decoder Terminal Interface

Information	Input Command	Output format	Commands and Examples (see notes) 1)	
PI(ON)	PION	s. example	PI(ON):	D313 D313 D313 D313 D313 D313 D314 D314 D314 ...
PS(ON)	PSON	EN 50067 3)	PS(ON):	D313: BAYERN 3: D314: BAYERN 4: D312: BAYERN 2: ...
AF(ON)	AFON	see example	A: AF(ON):	D313: 25 96.7/99.8 96.9/94.4 99.3/ ... D314: 25 98.3/97.4 94.1/100.9 95.5/ ... 98.0 93.1/ ...
			B AF(ON):	D313: TN 91.9: AF 99.5 97.6 97.4 TN 100.7: AF 95.9 98.5 ... D314: TN 91.8: AF 98.3 100.8 TN 94.8: AF 97.4 ...
				<i>Version (A or B) as a function of the information received</i>
EG(ON)	EG	0/1	EG:	D312:0 D513:0 D313:0 ...
LA(ON)	LA	0/1	LA:	D312:1 D513:0 D313:0 ... <i>LA from group 1A not visible</i>
LN(ON)	LN	\$0000-1FFF	LN:	D312:0422 D513:1A83 D313:0000 ...
PTY(ON)	PTYON	00-31	PTY(ON):	D314:14 D312:16 D317:01 D313:10 D314:14 ...
TP(ON)	TPON	J/N	TP(ON):	D312:N D317:J D313:J D314:N ... <i>TP and TA also from 14B for all ON with TP = 1</i>
TA(ON)	TAON	0/1	TA(ON):	D313:0 D317:0 D313:11111111 D313:1 ... <i>TP and TA also from 14B for all ON with TP = 1</i>
PIN(ON)	PION		PIN(ON):	D313:14. 13:30 D314:14. 13.35 D313:14. 13.05 ...
IH(ON)	IHON	\$0000-1FFF	IH(ON):	D314:FFFF D312:--- D317:0001 ...
A10(ON)	A10ON	\$0000-1FFF	A10(ON):	D312:--- D317:--- D313:--- ...
A11(ON)	A11ON	\$0000-1FFF	A11(ON):	D314:--- D312:--- D317:--- ...
A12(ON)	A12ON	0/1	A12(ON):	D313:0 D314:1 D312:- ...
A13(ON)	A13ON	\$000-3FF	A13(ON):	D313:000 D314:000 D312:--- ...
AC(ON)	ACON	\$0-7	AC(ON):	D313:7 ... <i>with TP networks only. at beginn of Traffic announcement</i>
AI(ON)	AION	sse above	PI(ON):	"D313" <i>A single output of all EON information from the memory for above PI code in the sequence indicated and in the format shown (without PI codes)</i>

Explanation:

- " no input.
- not received at the time expected
- \$ Hex character
- / with output format: or

- X all channels with IH and TDC
- AC User code
- EG Extendet Generic Indicator
- LN Linkage number
- LA Linkage Actuator
- TN Tuned Network

Notes:

- 1) If the inputs are erroneous, there is a new request.
- 2) The most significant bit of the 8-bit character is not output: if it is "1", the respective character is replaced by "#" for the output.
- 3) The correct sequence is as follows: block 2, block 3, block 4.
- 4) Bit position according to RDS standard.

**Operation Decoder DMC01 - DMDC
Terminal Protokoll**

Table 1: Cont.

Information	Input Command	Output format	Commands and Examples (see notes) 1)	
LA	LA	0/1	LA: ... 111111111100000 ...	LA from Gruppe 1A
AC	AC	0-7, \$000-FFF	AC: ... 1,45F 6,123 0,FE0 1,45F ...	AC and contents group 1A, block 3
1A	1A	\$00-1F \$0000-FFFF \$0000-FE00	1A: 06,945F,715E 06,E123,715E 05,8FE ...	(format block 2, bits m ₀₄ -m ₀₀) 3,4) (format block 3, AC + contents) (format block 4, PIN)
1B	1B	\$00-1F \$1001-FFFF \$0000-FE00	1B: 00,D781,715E 1F,D781,715E ...	(format block 2, bits m ₀₄ -m ₀₀) 4) (format block 3, PI) (format Block 4, PIN)
3A	3A	\$00-1F \$0000-FFFF \$0000-FFFF	3A: 12,3456,7890 1F,FFFF,FFFF ...	(format block 2, bits m ₀₄ -m ₀₀) 4) (format block 3) (format block 4)
3B	3B	\$00-1F \$1001-FFFF \$0000-FFFF	3B: 00,D781,7890 1F,D781,7890 ...	(format block 2, bits m ₀₄ -m ₀₀) 4) (format block 3, PI) (format block 4)
4A	4A	\$0-7 \$0000-FFFF \$0000-FFFF	4A: 5,68D6,DA28 7,68D6,DA28 ...	(format block 2, bits m ₀₄ -m ₀₂) 4) (format block 3) (format block 4)
4B	4B	see 3B	4B:	(if 4B is not received)
5A (TDC)	5A	see 3A	5A(TDC): 15,3456,7890 1B,FFFF,0000 ...	(channel number in hex)
5B (TDC)	5B	see 3B	5B(TDC): 08,D781,7890 15,D781,7890	(channel number in hex)
7A	7A	see 3A	7A: 00,5034,36FF 10,6048,76FF ...	
7B	7B	see 3B	7B: 12,D781,7890 1F,D781,7890 ...	
8A	8A	see 3A	8A:	(if 8A is not received)
8B	8B	see 3B	8B: 12,D781,7890 12,D781,7890 ...	
9A	9A	see 3A	9A: 12,3456,7890 12,3456,7890 ...	
9B	9B	see 3B	9B:	(if 9B is not received)
10A	10A	see 3A	10A:	(if neither 10A nor 10B is received)
10B	10B	see 3B	10B:	(if neither 10A nor 10B is received)
11A	11A	see 3A	11A: 00,0000,0000 1F,FFFF,FFFF ...	
11B	11B	see 3B	11B: 00,D781,1234 1F,D781,0000 ...	
12A	12A	see 3A	12A: 00,3456,7890 0F,1234,0000 ...	
12B	12B	see 3B	12B: 1F,D781,7890 00,D781,7890 ...	
13A	13A	see 3A	13A: 12,3456,7890 12,3456,7890 ...	
13B	13B	see 3B	13B: 12,D781,7890 12,D781,7890 ...	
15A	15A	see 3B	15A: 12,3456,7890 12,3456,7890 ...	

Explanation:

- " no input, only used for identification of inputs
- not received at the time expected
- \$ Hex character
- / with output format: or

- X all channels with IH and TDC
- AC User code (Anwendungscode)
- EG Extended Generic Indicator
- LN Linkage Number
- LA Linkage Actuator
- TN Tuned Network

Notes:

- 1) If the inputs are erroneous, there is a new request
- 2) The most significant bit of the 8-bit character is not output: if it is "1", the respective character is replaced by "#" for the output.
- 3) The correct sequence is as follows: block 2, block 3, block 4.
- 4) Bit position according to RDS standard.

**Operation Decoder DMC01 - DMDC
Terminal Protokol**

Table 2: Settings via Decoder Terminal Interface

Menue	Input 1) Command	Commands and Examples (see notes) 2)		
RATED VALUES (and correction)	SPGL	Rated value	-24.5 dB	(Range: -26 ... -14 dB, Step: 0.1 dB): "-24.1"
	PGK	Level correction	+ 2.5 dB	(Range: -3 ... + 6 dB, Step: 0.1 dB): "-2.8"
	PHK	Phase correction	-3g	(Range: -10 ... + 10 g, Step: 1 g): "4"
LIMITS	B POWER	Power failure		(B or A): "B"
	A POWER, B	B Power failure	7s	(Range: 1 ... 30 s, Step: 1s): "02"
	A POWER, A	A Power failure	15s	(Range: 1 ... 30 s, Step: 1s): "20"
	B SRC, B	B RDS source	6	(Range: 2 ... 20, Step: 2): "4"
	A SRC, A, 4 1)			
	B INFO, B	B RDS information	2,10 s	(Range: 2 ... 5, Step: 1, Range: 2/5/10/20 s): "3,10"
	A INFO, A	A RDS information	5,20 s	(Range: 2 ... 5, Step: 1, Range: 2/5/10/20 s): "4,20"
	B PGL, B	B Tolerance RDS level 0.4 dB, 20 s		(Range: 0.4 ... 2 dB, Step: 0.2; Range: 10 s ... 6 m, Step: 10 s/ 1 m): ".5,10s"
	A PGL, A	A Tolerance RDS level 0.6 dB, 20 s		(Range: 0.4 ... 2 dB, Step: 0.2; Range: 10 s ... 30 m, Step: 10 s/ 5 m): "1.0,5m"
	B PH, B	B Tolerance RDS phase	2 g, 10 s	(Range: 2 ... 15 g, Step: 1 g; Range: 10 s ... 6 m, Step: 10 s/ 1 m): "3,10s"
	A PH, A	A Tolerance RDS phase	3 g, 20 s	(Range: 2 ... 15 g, Step: 1 g; Range: 10 s ... 30 m, Step: 10 s/ 5 m): "5,10m"
	B R-V, B	B Tol. RDS-VRF phase	3 g, 20 s	(Range: 2 ... 15 g, Step: 1 g; Range: 10 s ... 6 m, Step: 10 s/ 1 m): "10,10s"
A R-V, A, 10	A Tol. RDS-VRF phase	10 g, 10 m	(Range: 2 ... 15 g, Step: 1 g; Range: 10 s ... 30 m, Step: 10 s/ 5 m): "10,10m"	
B STR, B	B Link	4%, 10 s	(Range: 2 ... 10%, Step: 2%; Range: 1 ... 15 s, Step: 1 s): "6,2"	
A STR	A Link	5%, 20 s	(B or A): "A" (Range: 5 ... 25%, Step: 5%; Range: 5 ... 60 s, Step: 5 s): "10,20"	
ERROR PROCESSING	MODE	Error processing	ERK	(Range: KOR/ERK): "KOR"
DATA COUPLING	DS	Data set	1	(Range: 0 ... 8/X): "2"
SOURCE	QU	Reference memory		(Range: 1 ... 8/X): "2"
		Reference	3)	PI:D781 PS:NDR 1 SH TP:1 "D78#,NDR###SH,0"
		Aktive	D	(Y/N/D): "Y"
INHIBIT	SP	Inhibit interface		(B, C, D ...): "B"
		Inhibit information		(AI, KI, PI, TP, ...): "IH,PIN,MS,AF"
TEST	TEST	Test result is output.		
CLEAR	CLEAR	Should all fault parameters be erased? (Y/N):		"Y"
HELP	HELP	Output of the available input functions.		
MENU	MENU	Output of the menu structure.		

Explanation:

Range	Value range of input.	Step	steps for input
"	is not entered, serves only to identify the entries	g	degree
/	with ranges and steps: or	s	seconds
X	all records data or reference memories	m	minutes
D	Coupling the reference memories to the data record address	#	Symbol is not checked
		AI	all informations
		KI	no information
		-	see 3)

Notes:

All inputs of a menu item must be coupled with ",", the inputs of various menu items with " ,".

- 1) The request is only made if no new or correct value is entered.
- 2) If possible, request and input must be made in one line. In the event of a faulty input, the unit issues a new request. Requests contain set value, values range and step size.
- 3) For PS (program service name), the input of the agreed check symbols "#", " ", " ", " " and " ; " with preceding "\ " is possible.

Terms and Explanation of Abbreviations

In what follows, terms and RDS information in abbreviated form are referred to that may require explanation. The definitions and special features of the working of the RDS processor are contained in EBU specification Tech. 3244 and in ARD specification 5/3.8.

Table of Contents

1	Spectral distribution	102
2	Data structure	102
3	Information structure	102
4	Explanation of RDS Items	103
	AF Alternative frequencies	103
	BV Access priority	103
	CT Clock time and date	103
	DI Decoder information	103
	DS Data set 1...8, 9, I, X	103
	GR Group sequence	103
	IH In-house information	103
	M/S Music/speech switch	103
	PI Program identification	103
	PIN Program item number	103
	PS Program service name	103
	PTY Program type	103
	RT Radiotext	103
	TA Traffic-announcement identification	104
	TDC Transparent Data Channel	104
	TP Traffic Program	104
	EON Enhanced other networks information	104
Fig. A0	Enhanced other networks information	104
	LA Method for linking RDS Programme Services	105
Fig. A1	Structure of Variant 12 of Block 3 of Type 14A groups (linkage information)	106
Fig. A2	Structure of Block 3 of Type 1A groups	106
Fig. B1	Structure of Block 3 of Type 1A groups	107
Fig. C1	Structure of Variant 0 of Block 3 of Type 1A groups (identification of a programme carrying EWS information)	108
Fig. C2	Allocation of Extended Country Codes (ECC) for the countries of the European Broadcasting Area	108
	EWS Emergency Warning System	109
Fig. D1	Structure of Variant 7 of Block 3 of Type 1A groups (identification of a programme carrying EWS information)	109
Fig. D2	Allocation of EWS message bits	109

Terms and Explanation of Abbreviations

1 Spectral distribution

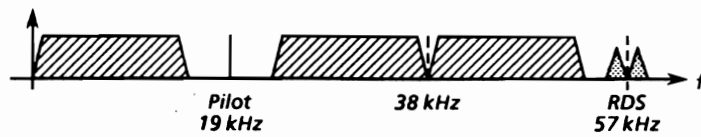

2 Data structure

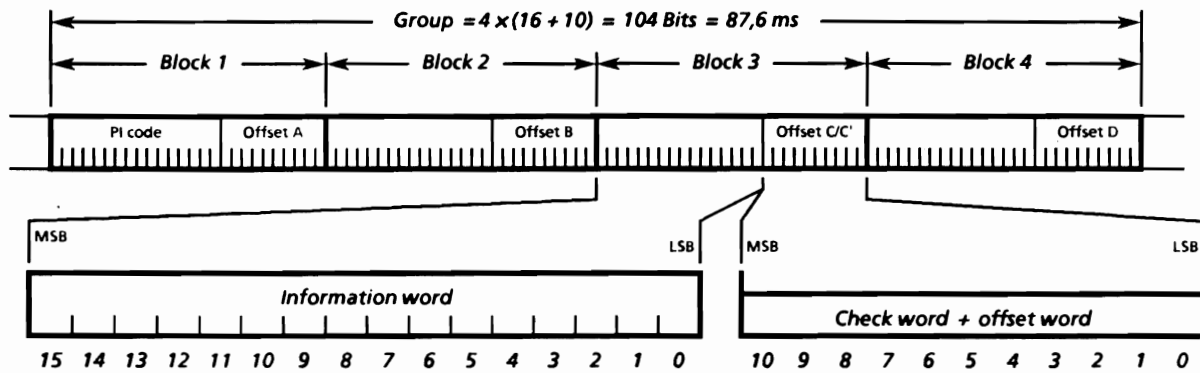

3 Information structure (march 1992)

Group	Block 1	Block 2	Block 3	Block 4
0A	PI	0, 0, TP, PTY, TA, M/S, DI	AF (2 x)	PS
0B	PI	0, 1, TP, PTY, TA, M/S, DI	PI	PS
1A	PI	1, 0, TP, PTY, Paging control	AC (one of 8)	PIN
1B	PI	1, 1, TP, PTY	PI	PIN
2A	PI	2, 0, TP, PTY, RT address	RT	RT
2B	PI	2, 1, TP, PTY, RT address	PI	RT
3A	not used	not used	not used	not used
3B	not used	not used	not used	not used
4A	PI	not used	Date	clocktime
4B	not used	not used	not used	not used
5A	PI	5, 0, TP, PTY, TDC channel	TDC data	TDC data
5B	PI	5, 1, TP, PTY, TDC channel	PI	TDC data
6A	PI	6, 0, TP, PTY, IH channel	IH daten	IH daten
6B	PI	6, 1, TP, PTY	PI	IH daten
7A	PI	7, 0, TP, PTY	Paging	Paging
7B	not used	not used	not used	not used
8A	not used	not used	not used	not used
8B	not used	not used	not used	not used
9A	PI	9, 0, TP, PTY, EWS	EWS	EWS
9B	not used	not used	not used	not used
10A	not used	not used	not used	not used
10B	not used	not used	not used	not used
11A	not used	not used	not used	not used
11B	not used	not used	not used	not used
12A	not used	not used	not used	not used
12B	not used	not used	not used	not used
13A	not used	not used	not used	not used
13B	not used	not used	not used	not used
14A	PI	14, 0, EON User code	EON data	EON data
14B	PI	14, 1, EON User code	PI	EON data
15B	PI	15, 0, TP, PTY, TA, M/S, DI	PI	15, 0, TP, PTY, TA, M/S, DI
15B	not used	not used	not used	not used

4 Explanation of RDS Items

AF Alternative Frequencies

A maximum of 70 AF lists with maximally 25 frequencies per list can be stored for each data set. The lists are transmitted continuously in ascending order.

BV Access Priority

This is a DMC operating mode that can be set via the terminal. The entry of certain features is only permitted on certain inputs. It is ignored if it is entered via other interfaces.

CT Clock Time and date

The RDS coder has a nonvolatile clock. The clock can be synchronized and started by the appropriate instructions.

DI Decoder Information

Operating information for the receiver decoder.

Operating information for the receiver decoder.

0	Mono
1	Stereo
2	Not yet assigned
3	Stereo dummy head
4	Mono compressed
5	Stereo compressed
6	Not yet assigned
7	Stereo compressed (dummy head)
8 to 15	Not yet assigned

DS Data set 1...8, 9, I, X

Data set is the general term for a collection of RDS features (PI, PS, etc). Eight main data sets are defined in the Coder. There is also a data set (DSIB) for startup. This data set is basically a ninth data set, but plays a special role when there are power or interface failures. Normally, you will enter standard data in this set that are valid for all programs if problems occur. Part of the data is then transferred to the main data sets and transmitted until current, valid data are available again.

GR Group sequence

Sequence of the data groups defined in the RDS system.

IH In-house information

The IH memory stores a maximum of 32 channels each with eight hexadecimal characters.

The IH feature can be transmitted up to 15 times (or continuously). The channels are transmitted in ascending order. Channel 0 is only transmitted if channels 1 through 31 are not assigned. Channel 2 is only transmitted if it has been activated from the front panel or by remote control. In a special version the "measurement start" signal is issued at the end of an IH group on channel 31. This is a negative pulse with the same duration as an RDS clock pulse. The negative edge corresponds to the end of the IH group to within $\pm 50 \mu\text{s}$.

M/S Music/speech switch

PI Program identification

PIN Program item number

PS Program service name

Eight characters are possible. Places that are not required are to be filled with spaces (ASCII character 32dec).

PTY Program type

0	No program type or undefined
1	NEWS
2	AFFAIRS
3	INFO
4	SPORT
5	EDUCATE
6	DRAMA
7	CULTURE
8	SCIENCE
9	VARIED
10	POP M
11	ROCK M
12	M.O.R. M
13	LIGHT M
14	CLASSICS
15	OTHER M
16 to 30	Not yet assigned
31	Alarm

RT Radio Text

The text memory holds eight texts of maximally 64 characters each for each data set. The texts are transmitted in ascending order. It is possible to send each text as many as eight times in direct succession. The text flag changes with every change of text. When all texts have been transmitted, they are repeated at the required rate.

Terms and Explanation of Abbreviations

Between one and 255 8-shot transmissions of the texts are possible (frequency 0 = constant transmission).

TA Traffic-announcement identification
TP bit = 1 is necessary for setting TA.

TDC Transparent data channel
The TDC memory can hold up to 256 characters. This is independent of the data-set memories and there is only one memory. You can send the TDC feature a specific number of times (1 to 15) or continuously.

TP Traffic Program

EON Enhanced other networks information

This feature can be used to update the information stored in a receiver about programme services other than the one received. Alternative frequencies (AF), the PS name, Traffic-programme and announcement identification (TA, TP) as well as Programme-type (PTY) and Programme-item-number (PIN) information can be transmitted for each other service. The relation to the corresponding programme is established by means of the relevant programme identification (PI).

Group Type 14

The format of the Type 14 group is shown in Fig. A0. It has two versions: A and B.

The A version is the normal form and shall be used for the background transmission of Enhanced Other Networks information. The maximum cycle time for the transmission of all data relating to all cross-referenced programme services shall be less

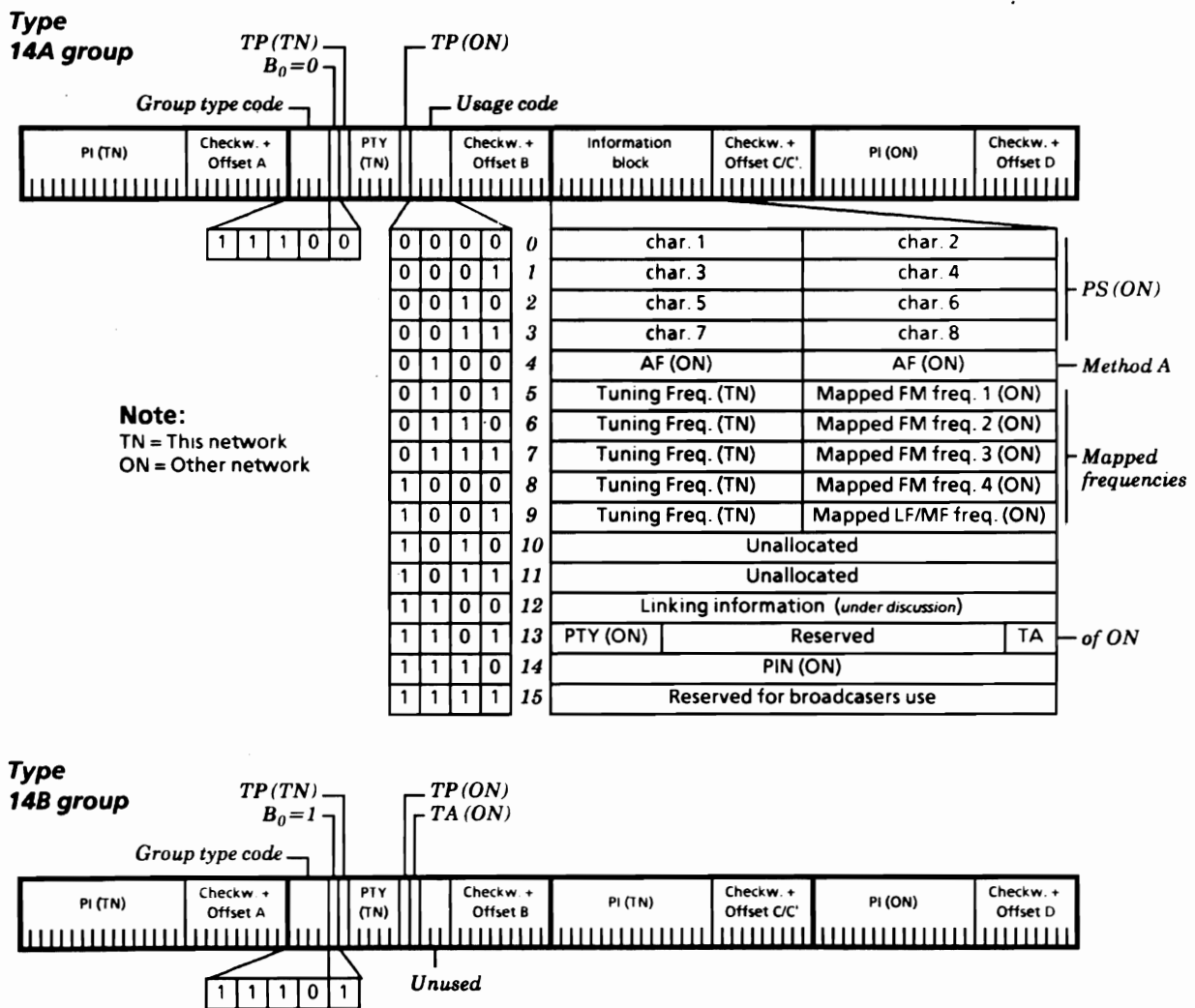

Fig. A0 Enhanced other networks information

Terms and Explanation of Abbreviations

than two minutes. The A version has sixteen variants which may be used in any mixture and order. Attention is drawn to the fact that two distinct options, namely Method A and the Method B, exist for the transmission of frequencies of cross-referenced programme services. A broadcaster should choose the most appropriate method for each cross-referenced programme service.

The B version of group Type 14 is used to indicate a change in the state of the TA flag of a cross-referenced programme service.

Mapped Frequency Method

Variants 5 to 9 of group Type 14A contain a mapped frequency pair in block 3. The sites for these pairs of frequencies shall be interpreted as follows:

- ▶ In all variants the first frequency is one which carries the tuned programme service in a certain reception area.
- ▶ In variant 5 the second frequency is the corresponding VHF/FM frequency for the cross-referenced programme service in the same reception area.
- ▶ If it is necessary to map one tuning frequency to more than one VHF/FM frequency for the cross-referenced programme service, then variants 6, 7 and 8 are used to indicate second, third, and fourth mapped frequencies, respectively.

Use of the TP, TA features

(Group types 0, 15B and 14)

For the tuned programme service, the code TP=0 in all groups and TA = 1 in Type 0 and Type 15B groups is now defined to indicate that it broadcasts EON information which cross-references at least one programme service which carries traffic information. RDS receivers which implement the EON Feature may use this code to signify that the listener can listen to the tuned programme service and nevertheless receive traffic messages from another programme service. RDS receivers which do not implement the EON Feature must ignore this code. Programme services which use the code TP=0, TA=1 must broadcast groups of Type 14B (at the appropriate times) relating to at least one programme service which carries traffic information, and has the flag TP = 1.

The TA flag within variant 13 of group Type 14A is used to indicate that the cross-referenced service is currently carrying a traffic announcement. This indication is intended for information only (e.g., for monitoring by broadcasters) and must not be used to initiate a switch even if traffic announcements are desired by the listener. A switch to the cross-referenced service should be made only when the flag TA = 1 is detected in group Type 14B.

The B version of group 14 is used to cause the receiver to switch to a programme service which carries a traffic announcement. When a particular programme service begins a traffic announcement, all transmitters which cross-reference this service via the EON feature shall broadcast at least eight appropriate group 14B messages within the shortest practicable period of time. At the discretion of the broadcaster, a sequence of Type 14B groups may be transmitted also when the TA flag is cleared. This option is provided only to assist in the control of transmitters; receivers must use the TA flag in the Type 0 or 15B groups of the service which carries the traffic announcements in order to switch back to the tuned programme service at the end of the received traffic announcement.

LA Method for linking RDS Programme Services

*Linking Actuator
(Linking RDS Programme Services)*

Introduction

The RDS system as specified in EBU Doc. Tech 3244 (expanded in Supplement 4) and EN 50067 provides the means by which information may be transmitted not only regarding the tuned programmed service, but also about other programme services.

A new Group type 14 was already defined, having two versions A and B. The A version of this Enhanced Other Network (EON) group has sixteen variants, selected by a usage code in Block 2. Variant 12 was foreseen for linkage information, but the linking method itself was not yet defined.

Linkage information

Linkage information provides the means by which several programme services, each characterized by its own PI code, may be treated by a receiver as a single service

Terms and Explanation of Abbreviations

during times a common programme is carried.

During such times each programme service retains its unique identity, i.e., the programme service must keep its designated PI code and its AF (Alternative Frequency) list(s), but may change programme related features such as PS, PTY, RT, TP and TA to reflect the common programme.

Linkage information is conveyed in four data elements. These are:

LA	Linkage Actuator	(1 bit)
EG	Extended Generic Indicator	(1 bit)
ILS	International Linkage Set	(1 bit)
LSN	Linkage Set Number	(12 bits)

This information is carried in Block 3 of variant 12 of Type 14A groups, and informs the receiver to which set of programme services the service defined by PI (ON), carried in Block 4 of the same group, belongs. PI (ON) addresses the memory bank in the receiver to which the data must be delivered.

When linkage information regarding the tuned programme service is transmitted, the PI code carried in Block 4 of the group, PI (ON), will be identical to the PI code carried in Block 1.

In order to achieve rapid de-linkage at the end of a common programme, the Linkage Actuator (LA) for the tuned network is also carried in Group type 1A, as bit 1 of Block 3.

This group type should normally be transmitted at least once every 5 seconds, preferably more frequently when a change in status occurs.

In Figures A1 and A2, bits indicated by "X" are not assigned to the linkage application and may be assumed to be in either state.

LA Linkage Actuator
(see Figs. A1 and A2)

This bit is set to 1 to inform the receiver that the programme service (indicated by PI (ON) in Block 4) is linked to the set of services described by LSN, the Linkage Set Number, at the present moment. If this bit is set to zero, a potential future link is indicated. The receiver may then use the linkage data to determine those services for which EON data might usefully be acquired.

EG Extended Generic Indicator
(see Fig. A1)

This bit is set to 1 to inform the receiver that the programme service, defined in Block 4 of Group type 14A, is a member of an extended generic set. Such a set of services is characterized by PI codes of the form WXYZ, where W is the common country code, X is the area code (and must lie in the range R1 to R12), Y is common to all such related services, and Z may assume any value. This mechanism permits a generically related set of services to comprise

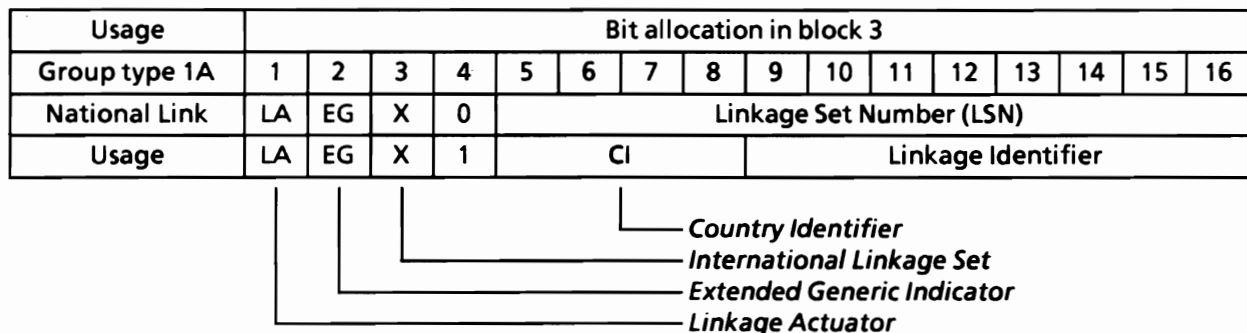

Fig. A1 Structure of Variant 12 of Block 3 of Type 14A groups (linkage information)

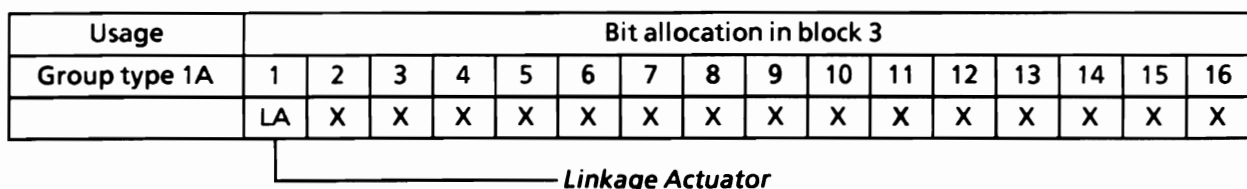

Fig. A2 Structure of Block 3 of Type 1A groups

Terms and Explanation of Abbreviations

more than twelve members, each with a unique PI code.

ILS International Linkage Set
(see Fig. A1)

In case of an international link, ILS (bit 4 of Block 3 in Variant 12 of Group type 14A) will be set to 1.

CI Country Identifier

Bits 1 to 4 of the LSN (derived from Block 4) shall be disregarded, instead Bits 5 to 8 of Block 3 shall be the country code of one of the two (or more) participating countries. For example, if Switzerland and Italy share a programme, they shall choose either HEX 4 or 5 for CI, and then agree on bits 9 to 16 for a unique Linkage identifier (LI).

LSN Linkage Set Number
(see Fig. A1)

The Linkage Set Number consists of altogether 16 bits. Bits 5 to 16 are carried in Block 3 of Variant 12 of Type 14A groups, where as bits 1 to 4 are derived from the country code of the PI (ON) carried in Block 4 of the same group. The resultant number is common to all programme services linked together as a set. It is unique to the set of linked programme services, and must be agreed nationally, or internationally if ILS is set to 1. No link exists (potential or active) if bits 5 to 16 of the LSN are all set to zero.

Group 1A/ Block 3

(see Fig. B1)

Conventions for application

A link (potential or active) between any two or more programme services is considered to be valid only when the programme services are all linked with a common Linkage Set Number (LSN). No more than one Linkage Set Number will apply to any given programme service at the same time. Interleaving of different Linkage Set Numbers relating to the same programme service, e.g., an active link and a future potential link, is not permitted. An active link between m programme services out of n potentially linked services ($m < n$) is considered to be valid only when the linkage actuators (LA) in the linkage words concerning those m services are set to one.

Usage codes of Block 3 of Type 1A Groups

The Radio Data System as specified in Doc. Tech 3244 and EN 50067 provides for the possibility of coding 16 bits in Block 3 of Type 1A groups, but does not define their application.

The following specifies the structure of Block 3 of Type 1A groups, and allocates these 16 bits to various applications.

Bits 2, 3 and 4 of Block 3 form the Usage code, which determines the application of data carried in bits 5 to 16. These applications are described separately as indicat-

Usage	Bit allocation in block 3															
	1	2	3	4	5	6	7	8	9	10	11	12	13	14	15	16
Group type 1A	1	2	3	4	5	6	7	8	9	10	11	12	13	14	15	16
Usage code 0	LA ¹	0	0	0	X	X	X	X	Extended Country Code							
Usage code 1	LA	0	0	1	Identification of TMC channel											
Usage code 2 to 5	⋮	⋮	⋮	⋮	not assigned											
Usage code 6	LA	1	1	0	For use by broadcasters											
Usage code 7	LA	1	1	1	Identification of EWS channel ³											

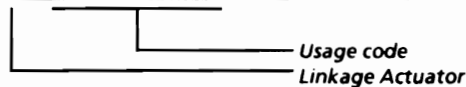

Notes:

- Bits indicated by "X" are not assigned and may be either in stage "1" or "0".
- 1 The Linkage Actuator is defined in the Method for Linking RDS Programme Services (Section A).
- 2 Extended Country Codes are defined separately (Section C)
- 3 The Emergency Broadcasting Systems (EBS) are defined separately (Section D)
- 4 Related to the TMC development
- 5 The coding of this information may be decided unilaterally by the broadcaster to suit the application. Radio-data receivers should entirely ignore this information.

Fig. B1 Structure of Block 3 of Type 1A groups

Terms and Explanation of Abbreviations

ed in the notes of Fig. B1. A broadcaster may use as many or as few of the Usage codes as he wishes, in any proportion and order.

Specification of extended Country Codes

The Radio Data System as specified in Doc. Tech 3244 and EN 50067 contains in an Appendix dealing with the coding of Programme Identification, a list of country codes, to be used as the first four bits of the 16 bit PI code. These identifications are given for all countries within the European Broadcasting Area. Since the code consists of only 4 bits, only 15 different possibilities exist (the code 0 is not used).

However there are more than 3 times as many countries and the same code is then repeated at distances where due to limitations in the radio wave propagation,

reception of programmes from two countries using the same identifier is impossible. While this concept provides sufficient flexibility for allocating the PI codes on a national level in each of the countries concerned, it does not permit unambiguous identification of each of the countries.

The following specification extend these country identifiers, and allocate a unique code to each country within the European Broadcasting Area.

The Extended Country Code (ECC) is carried in Variant 0 of Block 3 of Type 1A groups and consists of eight bits. This Variant should be transmitted at least once every minute.

The bit allocation of the Extended Country Codes is given in Fig. C1, and the Codes are given in Fig. C2.

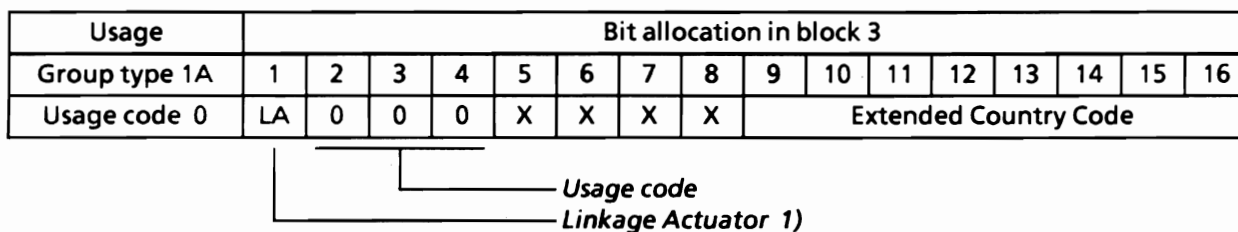

Note:

1) The Linkage Actuator is defined in the Method for Linking RDS Programme Services (Section A)

Fig. C1 Structure of Variant 0 of Block 3 of Type 1A groups
(identification of a programme carrying EWS information)

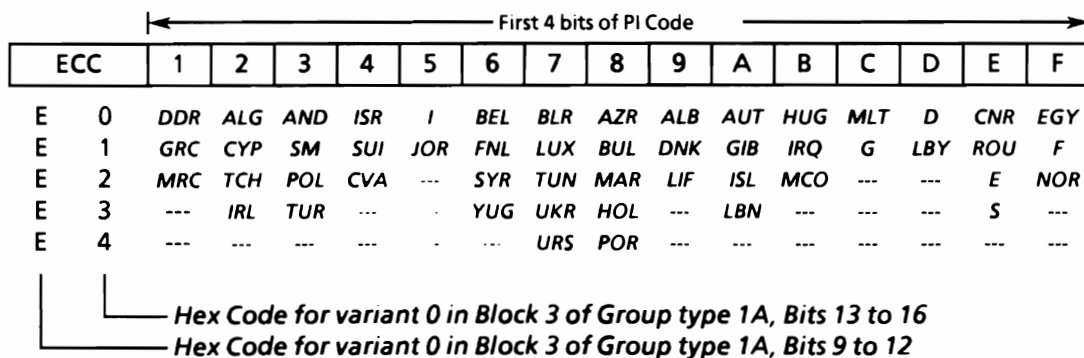

Fig. C2 Allocation of Extended Country Codes (ECC)
for the countries of the European Broadcasting Area

Terms and Explanation of Abbreviations

EWS Emergency Warning System

EWS Function

A number of countries are interested in providing comprehensive national emergency broadcast system information, using codes that for reason of national secrecy cannot be fully detailed. This information will only be broadcast in cases of extreme national emergency, and will thus not unduly overload the RDS channel. The new service is independent of the already specified alarm code (PTY = 31).

The following allocations are required to operate the new service:

Group Type 1A

Variant 7 (Usage code) in Block 3 of Group type 1A (see Fig. D1) is used to identify the programme that carries these warning messages to enable specific receivers, evaluating these messages to automatically tune to the corresponding channel. The repetition rate depends on the exact national implementation, but should normally not exceed one Group type 1A every two seconds.

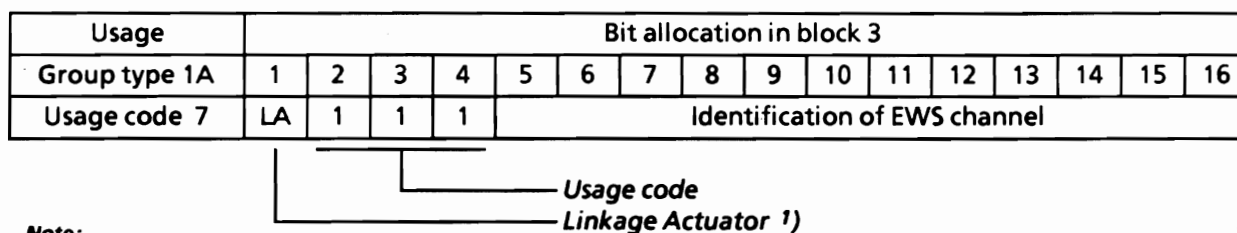

Note:

¹⁾ The Linkage Actuator is defined in the Method for Linking RDS Programme Services (Section A)

Fig. D1 Structure of Variant 7 of Block 3 of Type 1A groups (identification of a programme carrying EWS information)

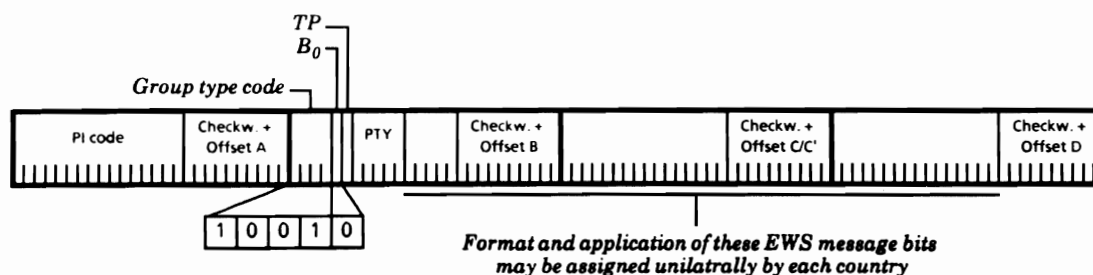

Fig. D2 Allocation of EWS message bits

Appendix 2

AF codes

Explanation: LSHB least significant half byte MSHB most significant half byte --- Code not used

Table 1 EBU codes for number of frequencies

MSHB	LSHB for the second half byte															
	0	1	2	3	4	5	6	7	8	9	A	B	C	D	E	F
E	0	1	2	3	4	5	6	7	8	9	10	11	12	13	14	15
F	16	17	18	19	20	21	22	23	24	25	26	27	28	29	30	31

Table 2 EBU codes for long-frequency band (LW) and medium-frequency band (MW)

One-byte code, frequencies in kHz, steps 9 kHz

MSHB	LSHB for the second half byte															
	0	1	2	3	4	5	6	7	8	9	A	B	C	D	E	F
0	---	153	162	171	180	189	198	207	216	225	234	243	255	261	270	279
1	531	540	549	558	567	576	585	594	603	612	621	630	639	648	657	666
2	675	684	693	702	711	720	729	738	747	756	765	774	783	792	801	810
3	819	828	837	846	855	864	873	882	891	900	909	918	927	936	945	954
4	963	972	981	990	999	1008	1017	1026	1035	1044	1053	1062	1071	1080	1089	1098
5	1107	1116	1125	1134	1143	1152	1161	1170	1179	1188	1197	1206	1215	1224	1233	1242
6	1251	1260	1269	1278	1287	1296	1305	1314	1323	1332	1341	1350	1359	1368	1377	1386
7	1395	1404	1413	1422	1431	1440	1449	1458	1467	1476	1485	1494	1503	1512	1521	1530
8	1539	1548	1557	1566	1575	1584	1593	1602	FILL	---	---	---	---	---	---	---
9	SW	SW	SW	SW	SW	SW	SW	SW	SW	SW	SW	SW	SW	SW	SW	SW
A	VHF	---	---	---	---	---	---	---	---	---	---	---	---	---	---	---
B	---	---	---	---	---	---	---	---	---	---	---	---	---	---	---	---
C	---	---	---	---	---	---	---	---	---	---	---	---	---	---	---	---
D	---	---	---	---	---	---	---	---	---	---	---	---	---	---	---	---

KW-UKW: Two-byte codes: second byte with SW and first bytes with VHF (see tables 3 and 4);

FILL = fill code (88 hex)

Table 3 EBU codes for very-short-frequency band (VHF-FM)

Two-byte code, frequencies in MHz, steps 100 kHz

The first byte of the code is always A0, for the second byte see the following table:

MSHB	LSHB for the second half byte															
	0	1	2	3	4	5	6	7	8	9	A	B	C	D	E	F
0	87.5	87.6	87.7	87.8	87.9	88.0	88.1	88.2	88.3	88.4	88.5	88.6	88.7	88.8	88.9	89.0
1	89.1	89.2	89.3	89.4	89.5	89.6	89.7	89.8	89.9	90.0	90.1	90.2	90.3	90.4	90.5	90.6
2	90.7	90.8	90.9	91.0	91.1	91.2	91.3	91.4	91.5	91.6	91.7	91.8	91.9	92.0	92.1	92.2
3	92.3	92.4	92.5	92.6	92.7	92.8	92.9	93.0	93.1	93.2	93.3	93.4	93.5	93.6	93.7	93.8
4	93.9	94.0	94.1	94.2	94.3	94.4	94.5	94.6	94.7	94.8	94.9	95.0	95.1	95.2	95.3	95.4
5	95.5	95.6	95.7	95.8	95.9	96.0	96.1	96.2	96.3	96.4	96.5	96.6	96.7	96.8	96.9	97.0
6	97.1	97.2	97.3	97.4	97.5	97.6	97.7	97.8	97.9	98.0	98.1	98.2	98.3	98.4	98.5	98.6
7	98.7	98.8	98.9	99.0	99.1	99.2	99.3	99.4	99.5	99.6	99.7	99.8	99.9	100.0	100.1	100.2
8	100.3	100.4	100.5	100.6	100.7	100.8	100.9	101.0	101.1	101.2	101.3	101.4	101.5	101.6	101.7	101.8
9	101.9	102.0	102.1	102.2	102.3	102.4	102.5	102.6	102.7	102.8	102.9	103.0	103.1	103.2	103.3	103.4
A	103.5	103.6	103.7	103.8	103.9	104.0	104.1	104.2	104.3	104.4	104.5	104.6	104.7	104.8	104.9	105.0
B	105.1	105.2	105.3	105.4	105.5	105.6	105.7	105.8	105.9	106.0	106.1	106.2	106.3	106.4	106.5	106.6
C	106.7	106.8	106.9	107.0	107.1	107.2	107.3	107.4	107.5	107.6	107.7	107.8	107.9	108.0	---	---
D	---	---	---	---	---	---	---	---	---	---	---	---	---	---	---	---
E	---	---	---	---	---	---	---	---	---	---	---	---	---	---	---	---
F	---	---	---	---	---	---	---	---	---	---	---	---	---	---	---	---

Appendix AF codes

Table 4 EBU-codes for short-frequency band (SW)

Two-byte code, frequencies in kHz, steps 5 kHz

<i>first byte</i>	<i>second byte</i>															
	90	91	92	93	94	95	96	97	98	99	9A	9B	9C	9D	9E	9F
00	5950	7230	8510	9790	11070	12350	13630	14910	16190	17470	18750	20030	21310	22590	23870	25150
01	5955	7235	8515	9795	11075	12355	13635	14915	16195	17475	18755	20035	21315	22595	23875	25155
02	5960	7240	8520	9800	11080	12360	13640	14920	16200	17480	18760	20040	21320	22600	23880	25160
03	5965	7245	8525	9805	11085	12365	13645	14925	16205	17485	18765	20045	21325	22605	23885	25165
04	5970	7250	8530	9810	11090	12370	13650	14930	16210	17490	18770	20050	21330	22610	23890	25170
05	5975	7255	8535	9815	11095	12375	13655	14935	16215	17495	18775	20055	21335	22615	23895	25175
06	5980	7260	8540	9820	11100	12380	13660	14940	16220	17500	18780	20060	21340	22620	23900	25180
07	5985	7265	8545	9825	11105	12385	13665	14945	16225	17505	18785	20065	21345	22625	23905	25185
08	5990	7270	8550	9830	11110	12390	13670	14950	16230	17510	18790	20070	21350	22630	23910	25190
09	5995	7275	8555	9835	11115	12395	13675	14955	16235	17515	18795	20075	21355	22635	23915	25195
0A	6000	7280	8560	9840	11120	12400	13680	14960	16240	17520	18800	20080	21360	22640	23920	25200
0B	6005	7285	8565	9845	11125	12405	13685	14965	16245	17525	18805	20085	21365	22645	23925	25205
0C	6010	7290	8570	9850	11130	12410	13690	14970	16250	17530	18810	20090	21370	22650	23930	25210
0D	6015	7295	8575	9855	11135	12415	13695	14975	16255	17535	18815	20095	21375	22655	23935	25215
0E	6020	7300	8580	9860	11140	12420	13700	14980	16260	17540	18820	20100	21380	22660	23940	25220
0F	6025	7305	8585	9865	11145	12425	13705	14985	16265	17545	18825	20105	21385	22665	23945	25225
10	6030	7310	8590	9870	11150	12430	13710	14990	16270	17550	18830	20110	21390	22670	23950	25230
11	6035	7315	8595	9875	11155	12435	13715	14995	16275	17555	18835	20115	21395	22675	23955	25235
12	6040	7320	8600	9880	11160	12440	13720	15000	16280	17560	18840	20120	21400	22680	23960	25240
13	6045	7325	8605	9885	11165	12445	13725	15005	16285	17565	18845	20125	21405	22685	23965	25245
14	6050	7330	8610	9890	11170	12450	13730	15010	16290	17570	18850	20130	21410	22690	23970	25250
15	6055	7335	8615	9895	11175	12455	13735	15015	16295	17575	18855	20135	21415	22695	23975	25255
16	6060	7340	8620	9900	11180	12460	13740	15020	16300	17580	18860	20140	21420	22700	23980	25260
17	6065	7345	8625	9905	11185	12465	13745	15025	16305	17585	18865	20145	21425	22705	23985	25265
18	6070	7350	8630	9910	11190	12470	13750	15030	16310	17590	18870	20150	21430	22710	23990	25270
19	6075	7355	8635	9915	11195	12475	13755	15035	16315	17595	18875	20155	21435	22715	23995	25275
1A	6080	7360	8640	9920	11200	12480	13760	15040	16320	17600	18880	20160	21440	22720	24000	25280
1B	6085	7365	8645	9925	11205	12485	13765	15045	16325	17605	18885	20165	21445	22725	24005	25285
1C	6090	7370	8650	9930	11210	12490	13770	15050	16330	17610	18890	20170	21450	22730	24010	25290
1D	6095	7375	8655	9935	11215	12495	13775	15055	16335	17615	18895	20175	21455	22735	24015	25295
1E	6100	7380	8660	9940	11220	12500	13780	15060	16340	17620	18900	20180	21460	22740	24020	25300
1F	6105	7385	8665	9945	11225	12505	13785	15065	16345	17625	18905	20185	21465	22745	24025	25305
20	6110	7390	8670	9950	11230	12510	13790	15070	16350	17630	18910	20190	21470	22750	24030	25310
21	6115	7395	8675	9955	11235	12515	13795	15075	16355	17635	18915	20195	21475	22755	24035	25315
22	6120	7400	8680	9960	11240	12520	13800	15080	16360	17640	18920	20200	21480	22760	24040	25320
23	6125	7405	8685	9965	11245	12525	13805	15085	16365	17645	18925	20205	21485	22765	24045	25325
24	6130	7410	8690	9970	11250	12530	13810	15090	16370	17650	18930	20210	21490	22770	24050	25330
25	6135	7415	8695	9975	11255	12535	13815	15095	16375	17655	18935	20215	21495	22775	24055	25335
26	6140	7420	8700	9980	11260	12540	13820	15100	16380	17660	18940	20220	21500	22780	24060	25340
27	6145	7425	8705	9985	11265	12545	13825	15105	16385	17665	18945	20225	21505	22785	24065	25345
28	6150	7430	8710	9990	11270	12550	13830	15110	16390	17670	18950	20230	21510	22790	24070	25350
29	6155	7435	8715	9995	11275	12555	13835	15115	16395	17675	18955	20235	21515	22795	24075	25355
2A	6160	7440	8720	10000	11280	12560	13840	15120	16400	17680	18960	20240	21520	22800	24080	25360
2B	6165	7445	8725	10005	11285	12565	13845	15125	16405	17685	18965	20245	21525	22805	24085	25365
2C	6170	7450	8730	10010	11290	12570	13850	15130	16410	17690	18970	20250	21530	22810	24090	25370
2D	6175	7455	8735	10015	11295	12575	13855	15135	16415	17695	18975	20255	21535	22815	24095	25375
2E	6180	7460	8740	10020	11300	12580	13860	15140	16420	17700	18980	20260	21540	22820	24100	25380
2F	6185	7465	8745	10025	11305	12585	13865	15145	16425	17705	18985	20265	21545	22825	24105	25385
30	6190	7470	8750	10030	11310	12590	13870	15150	16430	17710	18990	20270	21550	22830	24110	25390
31	6195	7475	8755	10035	11315	12595	13875	15155	16435	17715	18995	20275	21555	22835	24115	25395
32	6200	7480	8760	10040	11320	12600	13880	15160	16440	17720	19000	20280	21560	22840	24120	25400
33	6205	7485	8765	10045	11325	12605	13885	15165	16445	17725	19005	20285	21565	22845	24125	25405
34	6210	7490	8770	10050	11330	12610	13890	15170	16450	17730	19010	20290	21570	22850	24130	25410
35	6215	7495	8775	10055	11335	12615	13895	15175	16455	17735	19015	20295	21575	22855	24135	25415
36	6220	7500	8780	10060	11340	12620	13900	15180	16460	17740	19020	20300	21580	22860	24140	25420
37	6225	7505	8785	10065	11345	12625	13905	15185	16465	17745	19025	20305	21585	22865	24145	25425
38	6230	7510	8790	10070	11350	12630	13910	15190	16470	17750	19030	20310	21590	22870	24150	25430
39	6235	7515	8795	10075	11355	12635	13915	15195	16475	17755	19035	20315	21595	22875	24155	25435
3A	6240	7520	8800	10080	11360	12640	13920	15200	16480	17760	19040	20320	21600	22880	24160	25440
3B	6245	7525	8805	10085	11365	12645	13925	15205	16485	17765	19045	20325	21605	22885	24165	25445
3C	6250	7530	8810	10090	11370	12650	13930	15210	16490	17770	19050	20330	21610	22890	24170	25450
3D	6255	7535	8815	10095	11375	12655	13935	15215	16495	17775	19055	20335	21615	22895	24175	25455
3E	6260	7540	8820	10100	11380	12660	13940	15220	16500	17780	19060	20340	21620	22900	24180	25460
3F	6265	7545	8825	10105	11385	12665	13945	15225	16505	17785	19065	20345	21625	22905	24185	25465

Appendix AF codes

Table: Cont

first byte	second byte															
	90	91	92	93	94	95	96	97	98	99	9A	9B	9C	9D	9E	9F
40	6270	7550	8830	10110	11390	12670	13950	15230	16510	17790	19070	20350	21630	22910	24190	25470
41	6275	7555	8835	10115	11395	12675	13955	15235	16515	17795	19075	20355	21635	22915	24195	25475
42	6280	7560	8840	10120	11400	12680	13960	15240	16520	17800	19080	20360	21640	22920	24200	25480
43	6285	7565	8845	10125	11405	12685	13965	15245	16525	17805	19085	20365	21645	22925	24205	25485
44	6290	7570	8850	10130	11410	12690	13970	15250	16530	17810	19090	20370	21650	22930	24210	25490
45	6295	7575	8855	10135	11415	12695	13975	15255	16535	17815	19095	20375	21655	22935	24215	25495
46	6300	7580	8860	10140	11420	12700	13980	15260	16540	17820	19100	20380	21660	22940	24220	25500
47	6305	7585	8865	10145	11425	12705	13985	15265	16545	17825	19105	20385	21665	22945	24225	25505
48	6310	7590	8870	10150	11430	12710	13990	15270	16550	17830	19110	20390	21670	22950	24230	25510
49	6315	7595	8875	10155	11435	12715	13995	15275	16555	17835	19115	20395	21675	22955	24235	25515
4A	6320	7600	8880	10160	11440	12720	14000	15280	16560	17840	19120	20400	21680	22960	24240	25520
4B	6325	7605	8885	10165	11445	12725	14005	15285	16565	17845	19125	20405	21685	22965	24245	25525
4C	6330	7610	8890	10170	11450	12730	14010	15290	16570	17850	19130	20410	21690	22970	24250	25530
4D	6335	7615	8895	10175	11455	12735	14015	15295	16575	17855	19135	20415	21695	22975	24255	25535
4E	6340	7620	8900	10180	11460	12740	14020	15300	16580	17860	19140	20420	21700	22980	24260	25540
4F	6345	7625	8905	10185	11465	12745	14025	15305	16585	17865	19145	20425	21705	22985	24265	25545
50	6350	7630	8910	10190	11470	12750	14030	15310	16590	17870	19150	20430	21710	22990	24270	25550
51	6355	7635	8915	10195	11475	12755	14035	15315	16595	17875	19155	20435	21715	22995	24275	25555
52	6360	7640	8920	10200	11480	12760	14040	15320	16600	17880	19160	20440	21720	23000	24280	25560
53	6365	7645	8925	10205	11485	12765	14045	15325	16605	17885	19165	20445	21725	23005	24285	25565
54	6370	7650	8930	10210	11490	12770	14050	15330	16610	17890	19170	20450	21730	23010	24290	25570
55	6375	7655	8935	10215	11495	12775	14055	15335	16615	17895	19175	20455	21735	23015	24295	25575
56	6380	7660	8940	10220	11500	12780	14060	15340	16620	17900	19180	20460	21740	23020	24300	25580
57	6385	7665	8945	10225	11505	12785	14065	15345	16625	17905	19185	20465	21745	23025	24305	25585
58	6390	7670	8950	10230	11510	12790	14070	15350	16630	17910	19190	20470	21750	23030	24310	25590
59	6395	7675	8955	10235	11515	12795	14075	15355	16635	17915	19195	20475	21755	23035	24315	25595
5A	6400	7680	8960	10240	11520	12800	14080	15360	16640	17920	19200	20480	21760	23040	24320	25600
5B	6405	7685	8965	10245	11525	12805	14085	15365	16645	17925	19205	20485	21765	23045	24325	25605
5C	6410	7690	8970	10250	11530	12810	14090	15370	16650	17930	19210	20490	21770	23050	24330	25610
5D	6415	7695	8975	10255	11535	12815	14095	15375	16655	17935	19215	20495	21775	23055	24335	25615
5E	6420	7700	8980	10260	11540	12820	14100	15380	16660	17940	19220	20500	21780	23060	24340	25620
5F	6425	7705	8985	10265	11545	12825	14105	15385	16665	17945	19225	20505	21785	23065	24345	25625
60	6430	7710	8990	10270	11550	12830	14110	15390	16670	17950	19230	20510	21790	23070	24350	25630
61	6435	7715	8995	10275	11555	12835	14115	15395	16675	17955	19235	20515	21795	23075	24355	25635
62	6440	7720	9000	10280	11560	12840	14120	15400	16680	17960	19240	20520	21800	23080	24360	25640
63	6445	7725	9005	10285	11565	12845	14125	15405	16685	17965	19245	20525	21805	23085	24365	25645
64	6450	7730	9010	10290	11570	12850	14130	15410	16690	17970	19250	20530	21810	23090	24370	25650
65	6455	7735	9015	10295	11575	12855	14135	15415	16695	17975	19255	20535	21815	23095	24375	25655
66	6460	7740	9020	10300	11580	12860	14140	15420	16700	17980	19260	20540	21820	23100	24380	25660
67	6465	7745	9025	10305	11585	12865	14145	15425	16705	17985	19265	20545	21825	23105	24385	25665
68	6470	7750	9030	10310	11590	12870	14150	15430	16710	17990	19270	20550	21830	23110	24390	25670
69	6475	7755	9035	10315	11595	12875	14155	15435	16715	17995	19275	20555	21835	23115	24395	25675
6A	6480	7760	9040	10320	11600	12880	14160	15440	16720	18000	19280	20560	21840	23120	24400	25680
6B	6485	7765	9045	10325	11605	12885	14165	15445	16725	18005	19285	20565	21845	23125	24405	25685
6C	6490	7770	9050	10330	11610	12890	14170	15450	16730	18010	19290	20570	21850	23130	24410	25690
6D	6495	7775	9055	10335	11615	12895	14175	15455	16735	18015	19295	20575	21855	23135	24415	25695
6E	6500	7780	9060	10340	11620	12900	14180	15460	16740	18020	19300	20580	21860	23140	24420	25700
6F	6505	7785	9065	10345	11625	12905	14185	15465	16745	18025	19305	20585	21865	23145	24425	25705
70	6510	7790	9070	10350	11630	12910	14190	15470	16750	18030	19310	20590	21870	23150	24430	25710
71	6515	7795	9075	10355	11635	12915	14195	15475	16755	18035	19315	20595	21875	23155	24435	25715
72	6520	7800	9080	10360	11640	12920	14200	15480	16760	18040	19320	20600	21880	23160	24440	25720
73	6525	7805	9085	10365	11645	12925	14205	15485	16765	18045	19325	20605	21885	23165	24445	25725
74	6530	7810	9090	10370	11650	12930	14210	15490	16770	18050	19330	20610	21890	23170	24450	25730
75	6535	7815	9095	10375	11655	12935	14215	15495	16775	18055	19335	20615	21895	23175	24455	25735
76	6540	7820	9100	10380	11660	12940	14220	15500	16780	18060	19340	20620	21900	23180	24460	25740
77	6545	7825	9105	10385	11665	12945	14225	15505	16785	18065	19345	20625	21905	23185	24465	25745
78	6550	7830	9110	10390	11670	12950	14230	15510	16790	18070	19350	20630	21910	23190	24470	25750
79	6555	7835	9115	10395	11675	12955	14235	15515	16795	18075	19355	20635	21915	23195	24475	25755
7A	6560	7840	9120	10400	11680	12960	14240	15520	16800	18080	19360	20640	21920	23200	24480	25760
7B	6565	7845	9125	10405	11685	12965	14245	15525	16805	18085	19365	20645	21925	23205	24485	25765
7C	6570	7850	9130	10410	11690	12970	14250	15530	16810	18090	19370	20650	21930	23210	24490	25770
7D	6575	7855	9135	10415	11695	12975	14255	15535	16815	18095	19375	20655	21935	23215	24495	25775
7E	6580	7860	9140	10420	11700	12980	14260	15540	16820	18100	19380	20660	21940	23220	24500	25780
7F	6585	7865	9145	10425	11705	12985	14265	15545	16825	18105	19385	20665	21945	23225	24505	25785

Appendix AF codes

Table 4: Cont.

<i>first byte</i>	<i>second byte</i>		92	93	94	95	96	97	98	99	9A	9B	9C	9D	9E	9F
	90	91														
80	6590	7870	9150	10430	11710	12990	14270	15550	16830	18110	19390	20670	21950	23230	24510	25790
81	6595	7875	9155	10435	11715	12995	14275	15555	16835	18115	19395	20675	21955	23235	24515	25795
82	6600	7880	9160	10440	11720	13000	14280	15560	16840	18120	19400	20680	21960	23240	24520	25800
83	6605	7885	9165	10445	11725	13005	14285	15565	16845	18125	19405	20685	21965	23245	24525	25805
84	6610	7890	9170	10450	11730	13010	14290	15570	16850	18130	19410	20690	21970	23250	24530	25810
85	6615	7895	9175	10455	11735	13015	14295	15575	16855	18135	19415	20695	21975	23255	24535	25815
86	6620	7900	9180	10460	11740	13020	14300	15580	16860	18140	19420	20700	21980	23260	24540	25820
87	6625	7905	9185	10465	11745	13025	14305	15585	16865	18145	19425	20705	21985	23265	24545	25825
88	6630	7910	9190	10470	11750	13030	14310	15590	16870	18150	19430	20710	21990	23270	24550	25830
89	6635	7915	9195	10475	11755	13035	14315	15595	16875	18155	19435	20715	21995	23275	24555	25835
8A	6640	7920	9200	10480	11760	13040	14320	15600	16880	18160	19440	20720	22000	23280	24560	25840
8B	6645	7925	9205	10485	11765	13045	14325	15605	16885	18165	19445	20725	22005	23285	24565	25845
8C	6650	7930	9210	10490	11770	13050	14330	15610	16890	18170	19450	20730	22010	23290	24570	25850
8D	6655	7935	9215	10495	11775	13055	14335	15615	16895	18175	19455	20735	22015	23295	24575	25855
8E	6660	7940	9220	10500	11780	13060	14340	15620	16900	18180	19460	20740	22020	23300	24580	25860
8F	6665	7945	9225	10505	11785	13065	14345	15625	16905	18185	19465	20745	22025	23305	24585	25865
90	6670	7950	9230	10510	11790	13070	14350	15630	16910	18190	19470	20750	22030	23310	24590	25870
91	6675	7955	9235	10515	11795	13075	14355	15635	16915	18195	19475	20755	22035	23315	24595	25875
92	6680	7960	9240	10520	11800	13080	14360	15640	16920	18200	19480	20760	22040	23320	24600	25880
93	6685	7965	9245	10525	11805	13085	14365	15645	16925	18205	19485	20765	22045	23325	24605	25885
94	6690	7970	9250	10530	11810	13090	14370	15650	16930	18210	19490	20770	22050	23330	24610	25890
95	6695	7975	9255	10535	11815	13095	14375	15655	16935	18215	19495	20775	22055	23335	24615	25895
96	6700	7980	9260	10540	11820	13100	14380	15660	16940	18220	19500	20780	22060	23340	24620	25900
97	6705	7985	9265	10545	11825	13105	14385	15665	16945	18225	19505	20785	22065	23345	24625	25905
98	6710	7990	9270	10550	11830	13110	14390	15670	16950	18230	19510	20790	22070	23350	24630	25910
99	6715	7995	9275	10555	11835	13115	14395	15675	16955	18235	19515	20795	22075	23355	24635	25915
9A	6720	8000	9280	10560	11840	13120	14400	15680	16960	18240	19520	20800	22080	23360	24640	25920
9B	6725	8005	9285	10565	11845	13125	14405	15685	16965	18245	19525	20805	22085	23365	24645	25925
9C	6730	8010	9290	10570	11850	13130	14410	15690	16970	18250	19530	20810	22090	23370	24650	25930
9D	6735	8015	9295	10575	11855	13135	14415	15695	16975	18255	19535	20815	22095	23375	24655	25935
9E	6740	8020	9300	10580	11860	13140	14420	15700	16980	18260	19540	20820	22100	23380	24660	25940
9F	6745	8025	9305	10585	11865	13145	14425	15705	16985	18265	19545	20825	22105	23385	24665	25945
A0	6750	8030	9310	10590	11870	13150	14430	15710	16990	18270	19550	20830	22110	23390	24670	25950
A1	6755	8035	9315	10595	11875	13155	14435	15715	16995	18275	19555	20835	22115	23395	24675	25955
A2	6760	8040	9320	10600	11880	13160	14440	15720	17000	18280	19560	20840	22120	23400	24680	25960
A3	6765	8045	9325	10605	11885	13165	14445	15725	17005	18285	19565	20845	22125	23405	24685	25965
A4	6770	8050	9330	10610	11890	13170	14450	15730	17010	18290	19570	20850	22130	23410	24690	25970
A5	6775	8055	9335	10615	11895	13175	14455	15735	17015	18295	19575	20855	22135	23415	24695	25975
A6	6780	8060	9340	10620	11900	13180	14460	15740	17020	18300	19580	20860	22140	23420	24700	25980
A7	6785	8065	9345	10625	11905	13185	14465	15745	17025	18305	19585	20865	22145	23425	24705	25985
A8	6790	8070	9350	10630	11910	13190	14470	15750	17030	18310	19590	20870	22150	23430	24710	25990
A9	6795	8075	9355	10635	11915	13195	14475	15755	17035	18315	19595	20875	22155	23435	24715	25995
AA	6800	8080	9360	10640	11920	13200	14480	15760	17040	18320	19600	20880	22160	23440	24720	26000
AB	6805	8085	9365	10645	11925	13205	14485	15765	17045	18325	19605	20885	22165	23445	24725	26005
AC	6810	8090	9370	10650	11930	13210	14490	15770	17050	18330	19610	20890	22170	23450	24730	26010
AD	6815	8095	9375	10655	11935	13215	14495	15775	17055	18335	19615	20895	22175	23455	24735	26015
AE	6820	8100	9380	10660	11940	13220	14500	15780	17060	18340	19620	20900	22180	23460	24740	26020
AF	6825	8105	9385	10665	11945	13225	14505	15785	17065	18345	19625	20905	22185	23465	24745	26025
B0	6830	8110	9390	10670	11950	13230	14510	15790	17070	18350	19630	20910	22190	23470	24750	26030
B1	6835	8115	9395	10675	11955	13235	14515	15795	17075	18355	19635	20915	22195	23475	24755	26035
B2	6840	8120	9400	10680	11960	13240	14520	15800	17080	18360	19640	20920	22200	23480	24760	26040
B3	6845	8125	9405	10685	11965	13245	14525	15805	17085	18365	19645	20925	22205	23485	24765	26045
B4	6850	8130	9410	10690	11970	13250	14530	15810	17090	18370	19650	20930	22210	23490	24770	26050
B5	6855	8135	9415	10695	11975	13255	14535	15815	17095	18375	19655	20935	22215	23495	24775	26055
B6	6860	8140	9420	10700	11980	13260	14540	15820	17100	18380	19660	20940	22220	23500	24780	26060
B7	6865	8145	9425	10705	11985	13265	14545	15825	17105	18385	19665	20945	22225	23505	24785	26065
B8	6870	8150	9430	10710	11990	13270	14550	15830	17110	18390	19670	20950	22230	23510	24790	26070
B9	6875	8155	9435	10715	11995	13275	14555	15835	17115	18395	19675	20955	22235	23515	24795	26075
BA	6880	8160	9440	10720	12000	13280	14560	15840	17120	18400	19680	20960	22240	23520	24800	26080
BB	6885	8165	9445	10725	12005	13285	14565	15845	17125	18405	19685	20965	22245	23525	24805	26085
BC	6890	8170	9450	10730	12010	13290	14570	15850	17130	18410	19690	20970	22250	23530	24810	26090
BD	6895	8175	9455	10735	12015	13295	14575	15855	17135	18415	19695	20975	22255	23535	24815	26095
BE	6900	8180	9460	10740	12020	13300	14580	15860	17140	18420	19700	20980	22260	23540	24820	---
BF	6905	8185	9465	10745	12025	13305	14585	15865	17145	18425	19705	20985	22265	23545	24825	---

Appendix AF codes

Table 4: Cont.

first byte	second byte		92	93	94	95	96	97	98	99	9A	9B	9C	9D	9E	9F
	90	91														
C0	6910	8190	9470	10750	12030	13310	14590	15870	17150	18430	19710	20990	22270	23550	24830	--
C1	6915	8195	9475	10755	12035	13315	14595	15875	17155	18435	19715	20995	22275	23555	24835	--
C2	6920	8200	9480	10760	12040	13320	14600	15880	17160	18440	19720	21000	22280	23560	24840	--
C3	6925	8205	9485	10765	12045	13325	14605	15885	17165	18445	19725	21005	22285	23565	24845	--
C4	6930	8210	9490	10770	12050	13330	14610	15890	17170	18450	19730	21010	22290	23570	24850	--
C5	6935	8215	9495	10775	12055	13335	14615	15895	17175	18455	19735	21015	22295	23575	24855	--
C6	6940	8220	9500	10780	12060	13340	14620	15900	17180	18460	19740	21020	22300	23580	24860	--
C7	6945	8225	9505	10785	12065	13345	14625	15905	17185	18465	19745	21025	22305	23585	24865	--
C8	6950	8230	9510	10790	12070	13350	14630	15910	17190	18470	19750	21030	22310	23590	24870	--
C9	6955	8235	9515	10795	12075	13355	14635	15915	17195	18475	19755	21035	22315	23595	24875	--
CA	6960	8240	9520	10800	12080	13360	14640	15920	17200	18480	19760	21040	22320	23600	24880	--
CB	6965	8245	9525	10805	12085	13365	14645	15925	17205	18485	19765	21045	22325	23605	24885	--
CC	6970	8250	9530	10810	12090	13370	14650	15930	17210	18490	19770	21050	22330	23610	24890	--
CD	6975	8255	9535	10815	12095	13375	14655	15935	17215	18495	19775	21055	22335	23615	24895	--
CE	6980	8260	9540	10820	12100	13380	14660	15940	17220	18500	19780	21060	22340	23620	24900	--
CF	6985	8265	9545	10825	12105	13385	14665	15945	17225	18505	19785	21065	22345	23625	24905	--
D0	6990	8270	9550	10830	12110	13390	14670	15950	17230	18510	19790	21070	22350	23630	24910	--
D1	6995	8275	9555	10835	12115	13395	14675	15955	17235	18515	19795	21075	22355	23635	24915	--
D2	7000	8280	9560	10840	12120	13400	14680	15960	17240	18520	19800	21080	22360	23640	24920	--
D3	7005	8285	9565	10845	12125	13405	14685	15965	17245	18525	19805	21085	22365	23645	24925	--
D4	7010	8290	9570	10850	12130	13410	14690	15970	17250	18530	19810	21090	22370	23650	24930	--
D5	7015	8295	9575	10855	12135	13415	14695	15975	17255	18535	19815	21095	22375	23655	24935	--
D6	7020	8300	9580	10860	12140	13420	14700	15980	17260	18540	19820	21100	22380	23660	24940	--
D7	7025	8305	9585	10865	12145	13425	14705	15985	17265	18545	19825	21105	22385	23665	24945	--
D8	7030	8310	9590	10870	12150	13430	14710	15990	17270	18550	19830	21110	22390	23670	24950	--
D9	7035	8315	9595	10875	12155	13435	14715	15995	17275	18555	19835	21115	22395	23675	24955	--
DA	7040	8320	9600	10880	12160	13440	14720	16000	17280	18560	19840	21120	22400	23680	24960	--
DB	7045	8325	9605	10885	12165	13445	14725	16005	17285	18565	19845	21125	22405	23685	24965	--
DC	7050	8330	9610	10890	12170	13450	14730	16010	17290	18570	19850	21130	22410	23690	24970	--
DD	7055	8335	9615	10895	12175	13455	14735	16015	17295	18575	19855	21135	22415	23695	24975	--
DE	7060	8340	9620	10900	12180	13460	14740	16020	17300	18580	19860	21140	22420	23700	24980	--
DF	7065	8345	9625	10905	12185	13465	14745	16025	17305	18585	19865	21145	22425	23705	24985	--
E0	7070	8350	9630	10910	12190	13470	14750	16030	17310	18590	19870	21150	22430	23710	24990	--
E1	7075	8355	9635	10915	12195	13475	14755	16035	17315	18595	19875	21155	22435	23715	24995	--
E2	7080	8360	9640	10920	12200	13480	14760	16040	17320	18600	19880	21160	22440	23720	25000	--
E3	7085	8365	9645	10925	12205	13485	14765	16045	17325	18605	19885	21165	22445	23725	25005	--
E4	7090	8370	9650	10930	12210	13490	14770	16050	17330	18610	19890	21170	22450	23730	25010	--
E5	7095	8375	9655	10935	12215	13495	14775	16055	17335	18615	19895	21175	22455	23735	25015	--
E6	7100	8380	9660	10940	12220	13500	14780	16060	17340	18620	19900	21180	22460	23740	25020	--
E7	7105	8385	9665	10945	12225	13505	14785	16065	17345	18625	19905	21185	22465	23745	25025	--
E8	7110	8390	9670	10950	12230	13510	14790	16070	17350	18630	19910	21190	22470	23750	25030	--
E9	7115	8395	9675	10955	12235	13515	14795	16075	17355	18635	19915	21195	22475	23755	25035	--
EA	7120	8400	9680	10960	12240	13520	14800	16080	17360	18640	19920	21200	22480	23760	25040	--
EB	7125	8405	9685	10965	12245	13525	14805	16085	17365	18645	19925	21205	22485	23765	25045	--
EC	7130	8410	9690	10970	12250	13530	14810	16090	17370	18650	19930	21210	22490	23770	25050	--
ED	7135	8415	9695	10975	12255	13535	14815	16095	17375	18655	19935	21215	22495	23775	25055	--
EE	7140	8420	9700	10980	12260	13540	14820	16100	17380	18660	19940	21220	22500	23780	25060	--
EF	7145	8425	9705	10985	12265	13545	14825	16105	17385	18665	19945	21225	22505	23785	25065	--
F0	7150	8430	9710	10990	12270	13550	14830	16110	17390	18670	19950	21230	22510	23790	25070	--
F1	7155	8435	9715	10995	12275	13555	14835	16115	17395	18675	19955	21235	22515	23795	25075	--
F2	7160	8440	9720	11000	12280	13560	14840	16120	17400	18680	19960	21240	22520	23800	25080	--
F3	7165	8445	9725	11005	12285	13565	14845	16125	17405	18685	19965	21245	22525	23805	25085	--
F4	7170	8450	9730	11010	12290	13570	14850	16130	17410	18690	19970	21250	22530	23810	25090	--
F5	7175	8455	9735	11015	12295	13575	14855	16135	17415	18695	19975	21255	22535	23815	25095	--
F6	7180	8460	9740	11020	12300	13580	14860	16140	17420	18700	19980	21260	22540	23820	25100	--
F7	7185	8465	9745	11025	12305	13585	14865	16145	17425	18705	19985	21265	22545	23825	25105	--
F8	7190	8470	9750	11030	12310	13590	14870	16150	17430	18710	19990	21270	22550	23830	25110	--
F9	7195	8475	9755	11035	12315	13595	14875	16155	17435	18715	19995	21275	22555	23835	25115	--
FA	7200	8480	9760	11040	12320	13600	14880	16160	17440	18720	20000	21280	22560	23840	25120	--
FB	7205	8485	9765	11045	12325	13605	14885	16165	17445	18725	20005	21285	22565	23845	25125	--
FC	7210	8490	9770	11050	12330	13610	14890	16170	17450	18730	20010	21290	22570	23850	25130	--
FD	7215	8495	9775	11055	12335	13615	14895	16175	17455	18735	20015	21295	22575	23855	25135	--
FE	7220	8500	9780	11060	12340	13620	14900	16180	17460	18740	20020	21300	22580	23860	25140	--
FF	7225	8505	9785	11065	12345	13625	14905	16185	17465	18745	20025	21305	22585	23865	25145	--